

# PARAGON Wall VAV

Demand-controlled comfort module for offices



## QUICK FACTS

- Comfort module for demand-controlled indoor climate
- Designed for installation in the rear edge of the room and ideally is positioned above the adjacent corridor's suspended ceiling
- Equipped with control equipment for stand-alone or connectable to BMS via Modbus
- Complete product with integrated damper for variable air flow control 0-100%
- Energy-efficient operation since the room is ventilated, heated and cooled exactly as called for by the load, neither more nor less
- Ventilation, cooling and heating (water)
- Straightforward installation with two optional water connection sides and centred air connection
- Adjustable air direction ADC and adjustable grille louvres
- Low installation height
- High capacity

## KEY FIGURES

Air flow range:		Pressure range:	Cooling capacity total:	Heating capacity:
l/s	m <sup>3</sup> /h	Pa	W	W
0 - 85	0 - 306	20 - 200	Up to 2682	Up to 4274

## SIZE

Length (mm)	Width (mm)	Height (mm)
800, 1100, 1400	722 (+0-20)	286

# Contents

<b>Technical description .....</b>	<b>3</b>
PARAGON Wall VAV .....	3
PARAGON Wall VAV in a nutshell.....	3
Basic function diagram.....	4
Air distribution.....	5
Control equipment.....	6
Room controller, LOCUS.....	9
Sensor module.....	10
SWICCT .....	11
<b>Technical data.....</b>	<b>12</b>
<b>Sizing .....</b>	<b>13</b>
<b>Installation .....</b>	<b>14</b>
Suspension .....	14
Connection - Air .....	14
Connection - Water .....	15
Water quality .....	16
<b>Accessories .....</b>	<b>17</b>
<b>Accessories, factory-fitted.....</b>	<b>18</b>
<b>Loose accessories .....</b>	<b>19</b>
<b>Accessory kits.....</b>	<b>22</b>
<b>Specification.....</b>	<b>25</b>
Specification .....	25
Delivery demarcation .....	25
Factory-fitted optional extras .....	25
Available to order, kit and accessories .....	26
A selection of our optional kits and accessories:.....	26
Ordering Key, Accessories .....	26
<b>Specification text.....</b>	<b>27</b>

# Technical description

## PARAGON Wall VAV

The product is a demand-controlled comfort module with integrated regulation which, with its mounted control equipment, brings air flow and cooling and heating under demand-control for the best energy efficiency and comfort.

The product has a unique slot opening that means we can always guarantee the right air flow into the room and this with our functional controller with many I/O possibilities.

This is a plug & play product for quick and easy installation.

The compact comfort module is primarily designed for offices.

The product provides high cooling/heating capacity through optimal utilisation of its cooling/heating coil even when the air pressure and airflows are low.

As the PARAGON Wall VAV uses the same grille for both the distribution of supplied air and the recirculation of the supply air, this makes a technical installation outside the relevant room possible, which gives several important advantages.

By utilising the space above the false ceiling in the adjoining corridor, service can be carried out in the corridor without the need for access to the room served by the unit. With only one grille to take into consideration, only one opening needs to be cut in the wall.



Figure 1. PARAGON Wall VAV, front view



Figure 2. PARAGON Wall VAV, rear view

## PARAGON Wall VAV in a nutshell

- Complete plug & play product with factory-fitted control equipment
- Low flow-generated noise level
- Draught-free indoor climate
- Straightforward installation with two optional water connection sides and centred air connection
- No fan in the room
- Dry system without condensation
- No need for any drainage system
- No filter
- Requires minimal maintenance
- Low energy consumption
- Guaranteed comfort through flexible adjustment of the direction of air discharge (ADC)
- Can ordered with or without grille.

## Sizes and variants

The product is available in three different lengths 800, 1100 and 1400 mm.

All sizes can be ordered with the water connection on the left or right short side.



www.eurovent-certification.com  
www.certiflash.com

## Version

PARAGON Wall VAV is available in the following variants:

Variant A: Ventilation, waterborne cooling.

Variant B: Ventilation, waterborne cooling and heating from a coil.

## Basic function diagram

### Offices

The primary air is supplied via duct connection in the rear edge of the unit and this builds up positive pressure inside the unit. The positive pressure distributes the primary air with relatively high velocity via two rows of nozzle holes, one row in the upper edge and one row in the lower edge of the outlet. The high velocity of the primary air creates negative pressure which generates induction of the room air.

The recirculation air is sucked into the unit through the same grille that is used for distributing air into the room.

The recirculation air is then conveyed through the coil where it is cooled, heated, if required, or just passes untreated, before it mixes with the primary air and is discharged into the room.

The air is ideally distributed to office rooms by discharging it in a fan shape and utilising as much of the ceiling and any intermediate walls as possible for preventing draughts in the occupied zone.

Horizontal air distribution is achieved by means of the ADC (Anti-Draught Control) feature. If vertical air distribution is desirable, this is achieved by setting the outlet grille vanes to slant upward or downward.

Our new generation PARAGON Wall VAV has variable k-factor setting and large air flow range.

See also WISE Paragon Wall for full integration in Swegon's WISE system.

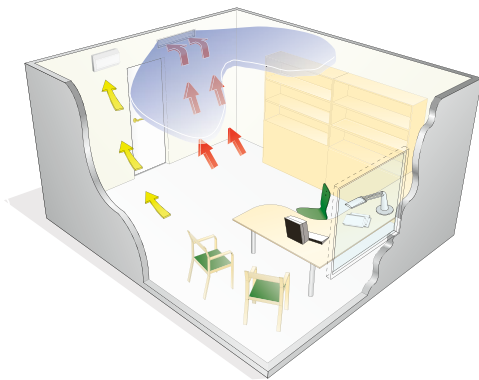

Figure 3 – Air distribution with the Paragon Wall VAV in a separate office room

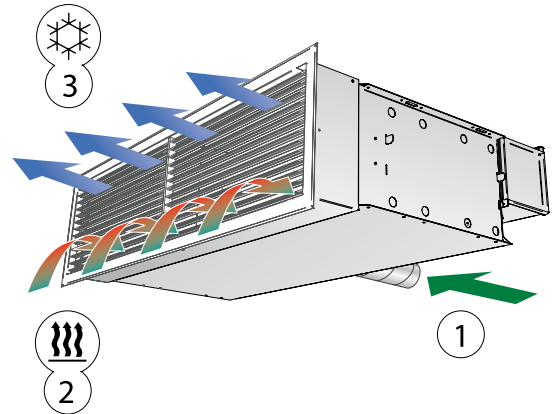

Figure 4 – Cooling function

- 1 = Primary air
- 2 = Induced room air
- 3 = Primary air mixed with chilled room air

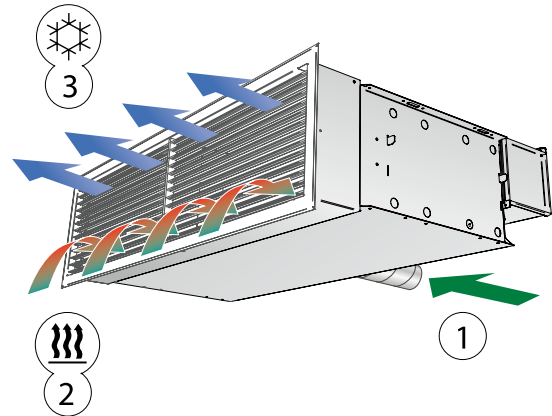

Figure 5 – Heating function (waterborne) also includes cooling function

- 1 = Primary air
- 2 = Primary air mixed with heated room air
- 3 = Induced room air

## Air distribution

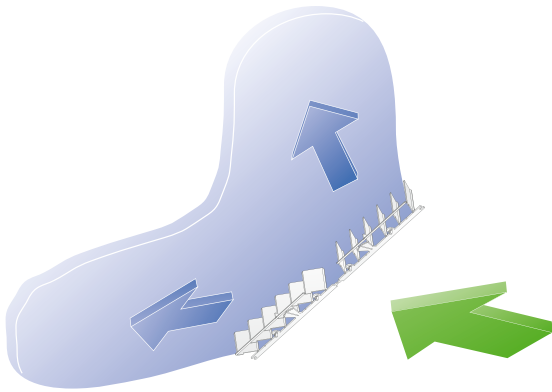

Figure 6 – Horizontal air distribution with ADC

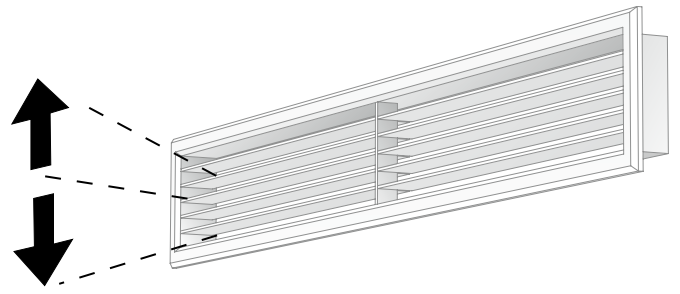

Figure 8. Vertical air distribution with adjustable louvres in the supply air grille.

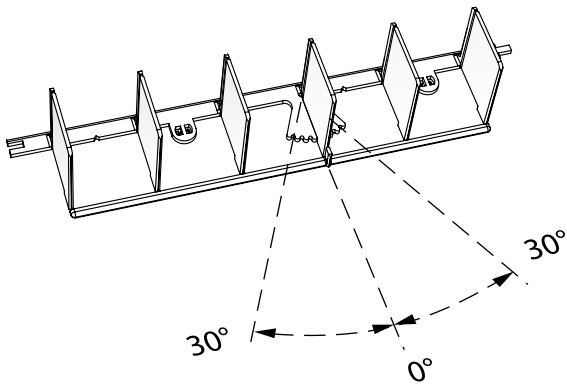

Figure 7. PARAGON ADC

## Control equipment

PARAGON Wall VAV is fully equipped with actuator, controller, pressure sensor, valves and valve actuators for optimum demand control according to the actual need.

As standard the product has two selectable water connection sides.

### Plug & Play

Factory-fitted control equipment makes the installation work simple. All components are accessible from the back of the product.

### Selectable factory-fitted optional extras:

*In addition to those above that are included in PARAGON Wall VAV*

Condensation sensor, CO<sub>2</sub> sensor, VOC sensor

In addition to the above factory-fitted options, loose accessories and kits (not factory-fitted) are also available:

PARAGON Wall VAV together with the URC1 room control system is the optimum demand-controlled solution for an office building.

URC1 is also used to control the CCO valve.

In the case of increased occupancy, the air flow increases from the economical low flow to the normal flow, while the temperature adjusts to the comfort level.

When the room is empty, the ventilation and temperature return to economic low flow.

In addition to the automatic room control, the user can manually adjust the temperature and air flow.

Also see the product sheet WISE PARAGON Wall on our website [www.swegon.se](http://www.swegon.se).



Figure 9. PARAGON with water connection on the right-hand side.



Figure 10. PARAGON with water connection on the left-hand side.



Figure 11. VAV controller for demand-controlled ventilation



Figure 12. Room controller/Setpoint selector switch LOCUS

## Operating case

Depending on the status of connected sensors, the controller adjusts the outputs from any of several possible operating modes.

Operating modes are described below, these are based on occupancy in the room, status of the current sensor or the signal from the main control system.

### Operating modes

There are a variety of operating modes for PARAGON Wall VAV:

- Occupancy mode.
- No occupancy mode.
- Holiday.
- Standby mode.
- Emergency mode.
- Commissioning mode.
- Summer night cooling.

### Occupancy mode

When the product receives a signal via the occupancy sensor that someone is present in the room, the valve actuator is regulated for cooling or heating water according to the chosen switching temperatures for cooling or heating linked to this operating mode. The air flow is controlled to the selected occupancy flow, but is naturally influenced by sensors such as condensation sensor, temperature sensor, window contact, possible air quality sensor, etc.

### No occupancy mode

When No occupancy mode is enabled, the system automatically switches to energy save mode. The system returns to the Occupancy mode when occupancy is registered again. In Energy-save mode/No occupancy mode, the valve actuator is controlled for cooling or heating water according to the status on other sensors in the room, but normally with a greater permissible difference between switching temperature cooling and heating than in Occupancy mode at the same time as the air is regulated to Min. flow.

### Holiday

When Holiday mode is enabled, the system automatically switches to energy save mode exactly as in No occupancy mode, but with the possibility to permit an even greater temperature difference. Controlled from the main control system.

### Standby mode

When the control system registers that a window is open the controller switches to Standby mode. When the window is closed the controller switches to Occupancy mode. When the controller is in Standby mode the room temperature is kept above 10 °C (frost protection).

### Emergency mode

In the event of a fire alarm, the air damper in the extract air duct is open or closed, depending on how the control system has been set. In Emergency mode cooling and heating are switched off. Supply air is normally switched off.

Operating mode EMERG can only be handled in control systems that are connected to the main control system via Modbus RTU.

### Commissioning mode

The "first open" function means that the water valves are open during installation, which simplifies filling, pressure testing and venting the water system.

The function is disabled automatically after being energised for about 6 minutes.

A clicking noise can be heard when the valves and dampers change over to NC mode (normally closed) and the normal control function is enabled.

More details about commissioning mode can be read in the sensor module description on page 10.

### Summer night cooling

The function means that cold outdoor air is used to cool the room during the night to the predefined level.

The function can only be handled in control systems that are connected to the main control system via Modbus RTU.

## Functions

### Change over

The function involves the use of only one valve actuator which should be wired to the cooling output terminal. This actuator then controls both the heating water and the cooling water, which is transported in the same pipe. An external temperature sensor should be used and this should measure on the main pipe where the water always circulates.

In winter, when heating is required, the valve opens if the water in the pipe is warmer than the temperature set point. If the water is colder, the valve does not open.

In summer, when cooling is required, the valve opens if the water in the pipe is colder than the temperature set point.

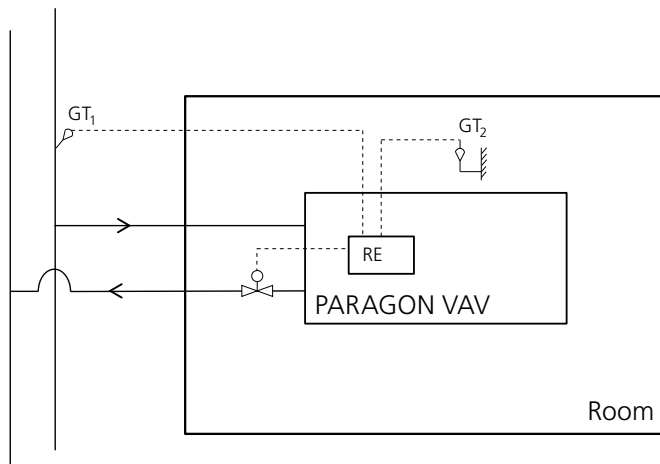

Figure 13.

- 2-pipe system with cooling water in the summer and heating water in the winter
- GT1 is placed where heating or cooling water always circulates
- Summer: If the room temperature T2 is higher than the water temperature T1, the valve opens when cooling is required.
- Winter: If the room temperature T2 is lower than the water temperature T1, the valve opens when heating is required.
- GT1 is connected to the regulator as an external temperature sensor
- In SWICCT or with LOCUS, it is possible to change the parameters so that the sensor is used for the change-over function
- GT2 is the temperature sensor which is located in the Sensor module
- The valve actuator must be connected to the regulator's cooling output.

### Activating valves

The function requires regular automatic activation of the water valves to avoid them beginning to stiffen or stick. During activation, all valves connected to the regulator are open for a maximum of 6 minutes, and then closed. The valves for the cooling system are activated first, followed by those for the heating system.

### Frost protection

The function means that heating operations start at 10°C to counteract the risk of damage that can otherwise occur due to freezing.



## Room controller, LOCUS

Main menu and explanation of symbols

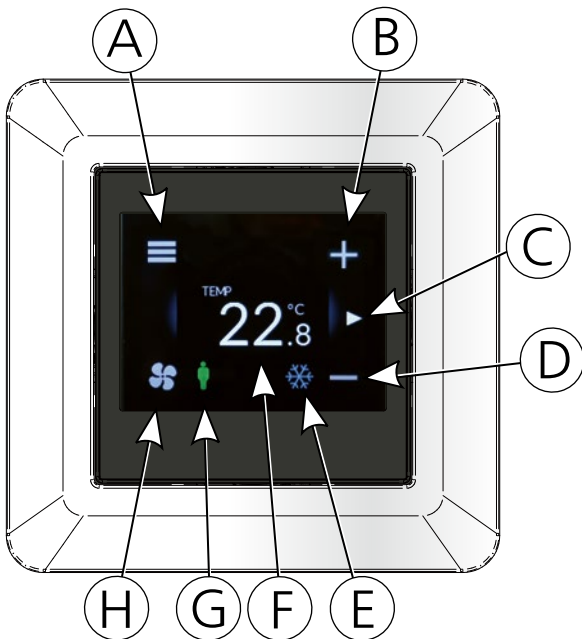

- A. menu
- B. increase
- C. swipe left to go to the next page
- D. decrease
- E. symbol showing ongoing cooling or heating
- F. shows programmed setpoint or measured temperature
- G. shows occupancy in the room
- H. press to activate boost flow

### Technical data

Display	Capacitive touch TFT Display QVGA 2.3"
Screen resolution	320x240
Communication	Modbus RTU via RS-485
Temperature sensor	Internal 10K NTC sensor
Operating temperature	+5 ... +40°C
Degree of protection	IP20
Dimensions	88 x 88 x 35 mm
Colour	Optional white or black frame
Operating voltage	12-40 VDC
Current requirement	0.5 W

### Connection

LOCUS	Connection	Description
VDD	RJ12	12-40 VDC power supply
A+	RJ12	RS-485 bus connection
B-	RJ12	RS-485 bus connection
GND	RJ12	Earth for 12-40 VDC power supply
Memory card slot		The user panel's software can be updated via a Micro SD card

### Standards and directives

The following standards have been observed:

EC Directive:	93/68/EEC
Low Voltage Directive:	2014/35/EU
Machinery Directive:	2006/42/EEC
EMC Directive:	2014/30/EU
RoHS Directive:	2002/95/EC
Vibrations:	EN-60721-3-3

### Description of display

Display	Description	Explanation
	Display in standby mode	Activated with a click
	Active main menu	Click on the + or - signs to increase/decrease the setpoint temperature
	Activated boost mode	
	Swipe left for next display page	Shows input values from connected sensors
	Swipe right to go back to the main menu	

For more detailed information about LOCUS room controller. See the following documentation at [www.swegon.com](http://www.swegon.com)

LOCUS Product datasheet

LOCUS Instructions for Use (IOM)

VAV Modbus

### Sensor module

The sensor module consists of an occupancy sensor and a temperature sensor in the same unit.

The sensor module is ordered separately and is mounted on a wall, flush mounted in a standard electrical box or surface-mounted.

The push buttons on the sensor module allow you to adjust the temperature in the room, put the PARAGON Wall VAV in commissioning mode and read the alarm list.

In normal mode, 6 LEDs indicate the selected temperature level. In the event of a fault, the relevant alarm is indicated in the form of flashing LEDs that is translated with the help of an alarm list.

The sensor module is connected to the controller with the help of an RJ12 cable.

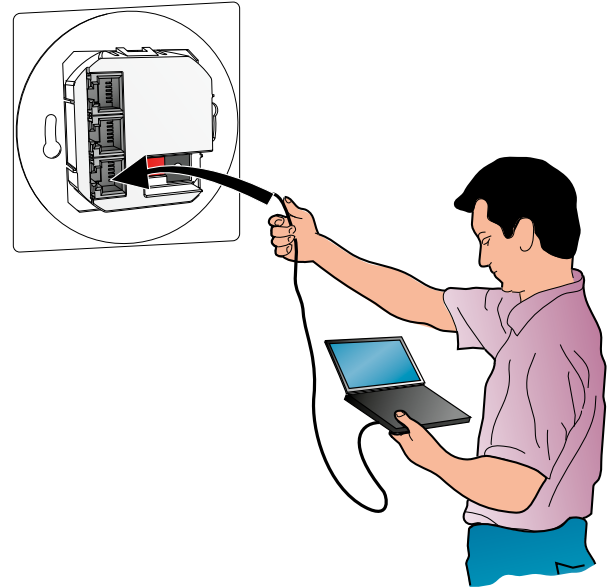

Figure 16. With the help of CABLE CONVERTER USB-RJ12 (RS485), you can easily connect a PC to make e.g. software settings. The connection can either be made on the rear of the Sensor module as illustrated, or directly on the controller. How to do this is described in the SWICCT manual.

### Temperature adjustment

Reduce the temperature by pressing the left-hand button



Increase the temperature by pressing the right-hand button

Each LED corresponds to an increase or decrease of the set point by one degree. Base setting of temperatures is made in SWICCT or SuperWISE

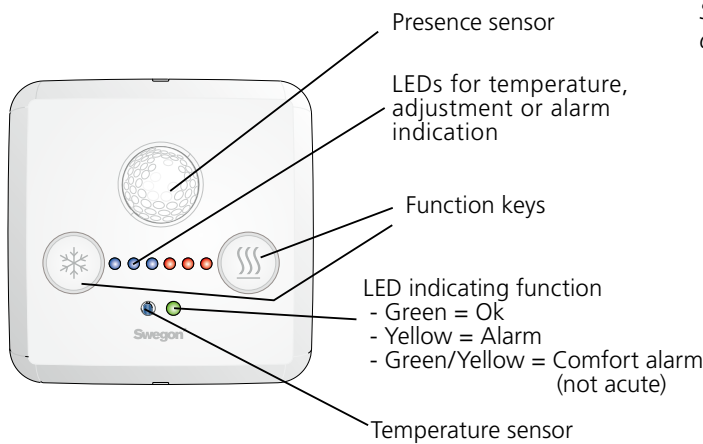

Figure 14. Sensor module seen from the front

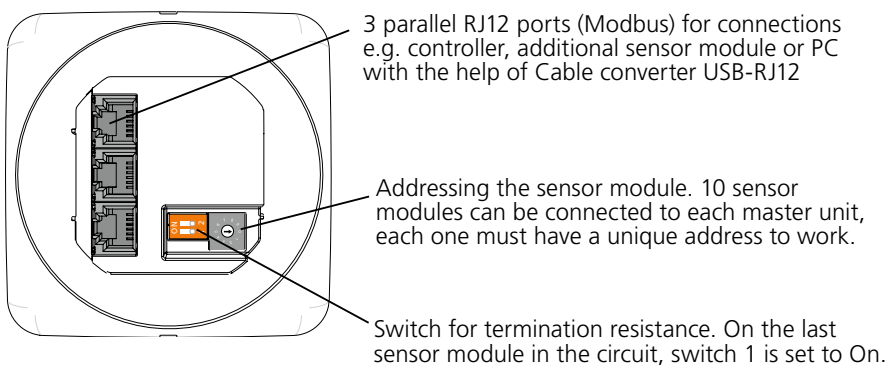
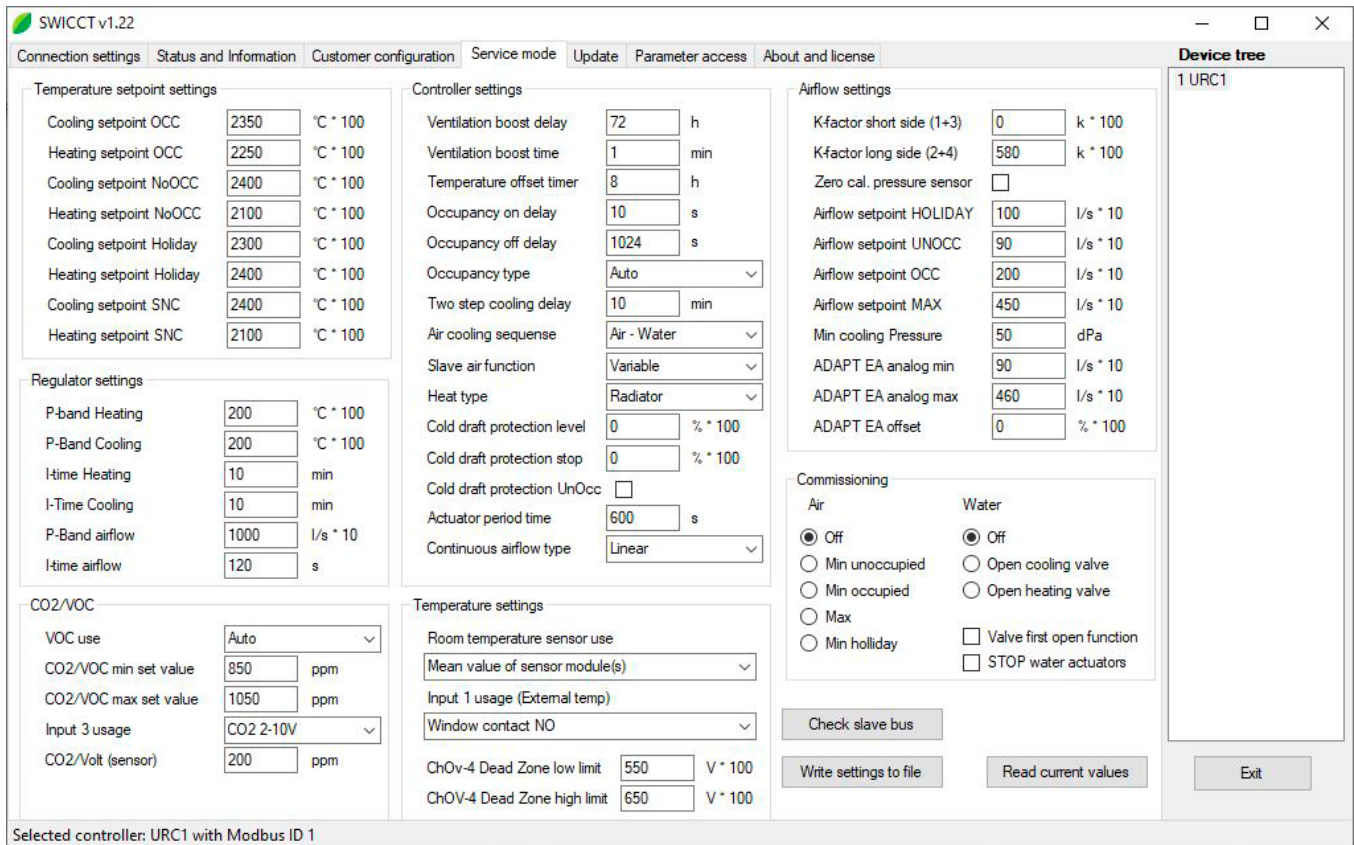

Figure 15. Sensor module seen from the back

## SWICCT

SWICCT (SWegon Indoor Climate Configuration Tool) is the software that makes it easy to make settings in the controller. (To make settings requires the cable "CABLE CONV. USB RJ-12", and the installation of this, see the SWICCT manual) Here it is possible to make all essential settings for the Product, for example;

- Base settings for temperature
- Use of external sensors, e.g. for air quality
- Air flows
- Commissioning



SWICCT is available for download from [www.swegon.se](http://www.swegon.se), both the software and a separate manual.

# Technical data

Cooling capacity total, max.	2682 W
Heating capacity, water, max.	4274 W
Air flow	0-85 l/s
	0-306 m <sup>3</sup> /h
Pressure range	20-200 Pa
Dimensions:	
Length:	800, 1100, 1400 mm
Width:	722 (+0-20) mm
Height:	286 mm
<i>See the dimensional drawing for exact measurements</i>	

## Power consumption

Power consumption for transformer sizing:	VA / unit
Actuator	6
Damper motor (UM24)*	2,5
Controller (URC1)*	1
Sensor module	1

\* Always included in the product

### Example A:

PARAGON Wall VAV 1100-B; 6+2,5+1+1 = 10,5 VA  
6 VA for cooling - OR heating actuator when they are normally regulated in sequence.

### Example B:

PARAGON Wall VAV 1100-B; 6+6+2,5+1+1 = 16,5 VA  
For operating modes such as Radiator Heat and Cold draught protection, power consumption will then be 6+6 VA for actuators when they are not regulated in sequence.

## Recommended limit values, water

Max. recommended operating pressure (above coil only): 1600 kPa \*

Max. recommended test pressure (across coil only): 2400 kPa \*

\* Applicable without control equipment mounted

Max. recommended pressure drop across the CCO valve: 20 kPa

Max. recommended pressure drop across a standard valve: 20 kPa

Min. permissible heating water flow: 0.013 l/s

Max. permissible supply flow temperature: 60 °C

Min. permissible cooling water flow: 0.04 l/s

Lowest permissible supply flow temperature: Must always be sized so that the system works without condensation

## Designations

P: Capacity (W, kW)

v: Velocity (m/s)

q: Flow (l/s)

p: Pressure, (Pa, kPa)

t<sub>r</sub>: Room temperature (°C)

t<sub>m</sub>: Mean water temperature (°C)

ΔT<sub>m</sub>: Temperature difference [t<sub>r</sub>-t<sub>m</sub>] (K)

ΔT: Temperature difference, between inlet and return (K)

ΔT<sub>i</sub>: Temperature difference, between room and supply air (K)

Δp: Pressure drop (Pa, kPa)

k<sub>p</sub>: Pressure drop constant

index:

k = cooling, l = air, v = heating, i = commissioning

# Sizing

## Easy and quick calculation of room products

Single Product Calculator "SPC" is a simple quick calculation for room products. Capacities, sounds, flows, isovels, etc. can be calculated and printouts can be made.

SPC is accessible from our product pages at [www.swegon.se](http://www.swegon.se) where there is a "Calculate" button. No login or software download needed, incredibly quick and easy!

The screenshot displays the Swegon Sizing Calculator for the PARAGON W VAV d 1100-B-R-125. The interface is divided into several functional areas:

- Luft (Air):** Displays air flow parameters such as 'Min luftflöde (stängt spärr)' and 'Måttligt Maxflöde (fullt öppet spärr)'.
- Produktkonfiguration (Product configuration):** Allows selection of 'Byggnad' (Building) and 'Byggnads' (Building) type.
- Galler (Grilles):** Configures grille settings like 'Vinkel' (Angle) and 'Rum' (Room).
- Kylfall (Cooling):** Sets cooling load parameters like 'Kylenergi' and 'Kylflöde'.
- Värmefall (Heating):** Sets heating load parameters like 'Värmeenergi' and 'Värmeledning'.
- Fabrikmonterade tillbehör (Factory-installed accessories):** Lists accessories like 'Regulator' and 'SYST VDN 215'.
- Regulator - konfigurationsinställningar (Regulator - configuration settings):** Provides settings for the regulator, including 'Regulator' type and 'Måttning' (Measurement).

The 'SYST VDN 215' window is currently open, showing a 3D model of the valve and its technical specifications:

- SYST VDN 215:** Vattenventil, rak, DN15 (1/2) K=0.07-0.89 m3/h
- Ingår i PRIMO VS-paket: SYST BK LURIA, PARAGON T-OMDELNING**

The background shows a 3D rendering of the PARAGON W VAV unit, highlighting its internal components and the regulator.

# Installation

## Suspension

The PARAGON Wall VAV has two holes on each short side for suspension and is mounted with a threaded rod in each hole.

A double threaded rod with a thread lock should be used if there is substantial distance between the overhead slab and the unit. A 200 mm threaded drop rod is used for surface mounting. The threaded rod, SYST MS M8 assembly piece must be ordered separately.

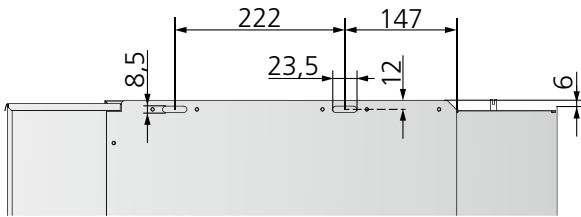

Figure 17. Suspension measurements

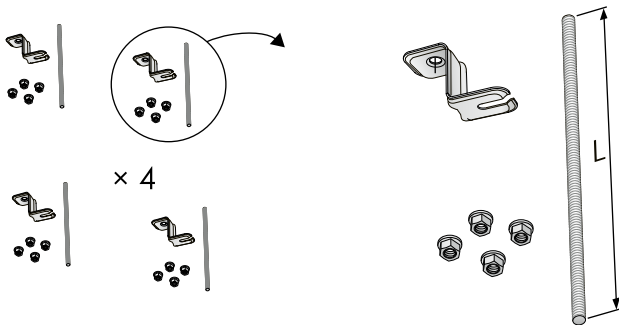

Figure 18. Assembly piece SYST MS M8-1, ceiling mount and threaded rod

## Lining

The work involving the casing can begin once PARAGON Wall VAV has been fully installed. The product is designed to be placed at the rear of the room adjacent to the corridor and installed in the space above the suspended ceiling in the corridor.

To simplify the work, cut-out dimensions are given in separate installation instructions at [www.swegon.com](http://www.swegon.com).

## Connection - Air

All variants have the air connection Ø125.

The air connection is centred at the rear of the product for easy access from both ends and the rear.

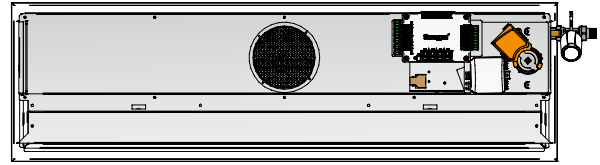

Figure 19. Rear view med water connection - right

## Connection - Water

### Connection dimensions

Standard variant with factory-fitted valves:

Length	Cooling	Heating
(mm)	Return	Return
800, 1100, 1400	DN15 male thread	DN15 male thread

Standard variant without factory fitted valves:

Length	Cooling	Heating
(mm)	Supply and return	Supply and return
800, 1100, 1400	plain pipe ends	plain pipe ends
	(Cu) Ø 12 x 1.0 mm	(Cu) Ø 12 x 1.0 mm

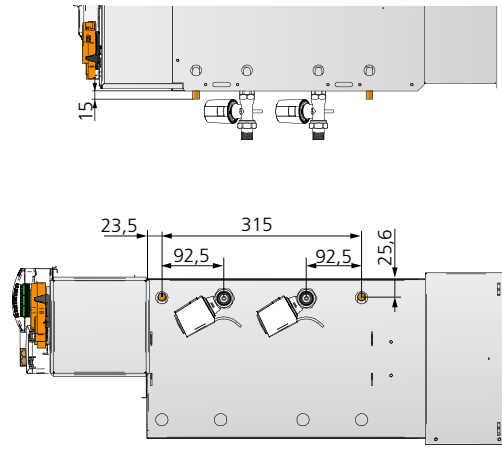

Figure 21. Dimensional drawing, water connection

### Connecting water

The water pipes are placed on the left or right short side of the product depending on the choice made.

Connect the water pipes using push-on couplings or compression ring couplings. Note that compression ring couplings require support sleeves inside the pipes.

Do not use solder couplings to connect the water pipes. High temperatures can damage the unit's existing soldered joints.

Flexible connecting hoses for water are available for flat-end pipes and valves, and can be ordered separately.

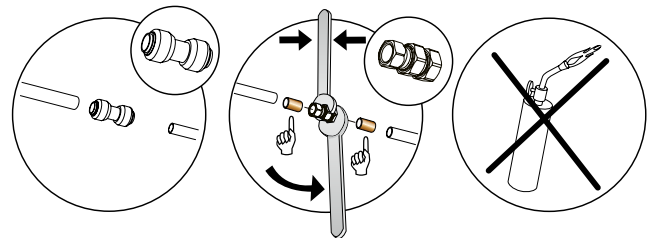

Note that compression ring couplings require support sleeves inside the pipes.

### Water connection on the right-hand side "R"

#### Cooling and heating R. all sizes

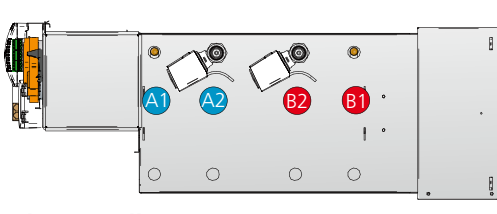

#### Cooling R, all sizes

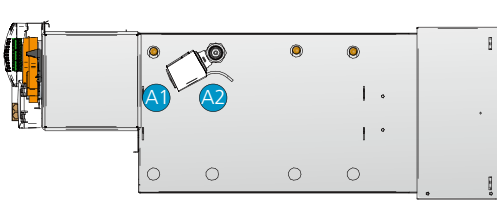
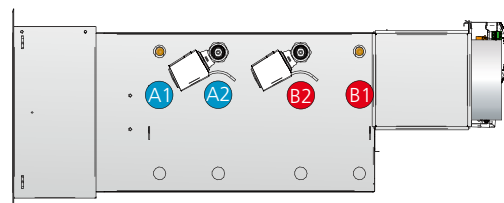

Figure 20. Water connection on right-hand side (R).

A1 = Cooling water, supply  
A2 = Cooling water, return  
B1 = Heating water, supply  
B2 = Heating water, return

### Water connection on the left-hand side "L"

#### Cooling and heating L. all sizes



#### Cooling L, all sizes

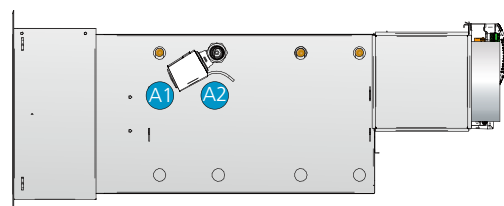

Figure 22. Water connection on left-hand side. (L).

A1 = Cooling water, supply  
A2 = Cooling water, return  
B1 = Heating water, supply  
B2 = Heating water, return

### Water quality

Swegon recommends water quality according to VDI 2035-2 for both the heating and cooling systems. In order to maintain the oxygen content in the water below the levels (<0.1 mg/l) prescribed in VDI 2035-2, it is recommended to install a vacuum degasser, particularly in the cooling system where it's more challenging to dissolved gas. It is also important that the pre-pressure in the expansion vessel is dimensioned according to EN-12828 for both the heating and cooling systems and that regular checks are made of the pre-pressure. The cooling and heating systems must be designed to prevent oxygen from entering the system, this is particularly important to consider when selecting flex hose, pipes and expansion vessels.

When the system is filled with fresh water, it has an oxygen content of approximately 8 mg/l, however, this oxygen is consumed quickly through corrosion processes and within a few days the oxygen in the water should be consumed. Nevertheless, it is important to avoid filling the system with fresh water unnecessarily.

Automatic deaerators are often installed to facilitate filling of the system. It is recommended that the automatic deaerators are turned off once the system has been fully vented to avoid these drawing in air in the system if the pre-pressure in the expansion vessel should drop.

### CCO valve

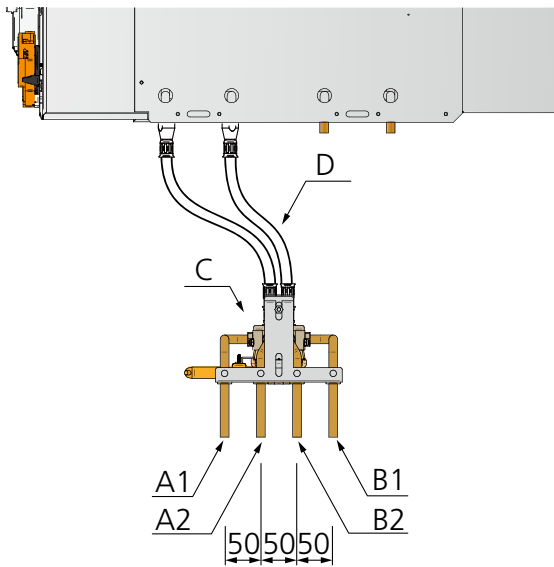

Figure 23. Water connection, CCO valve.

- A1 = Cooling water, supply
- A2 = Cooling water, return
- B1 = Heating water, supply
- B2 = Heating water, return
- C = CCO valve
- D = Flexible hose

### Valves for cooling and cooling and heating

#### PARAGON Wall B (cooling and heating) with valves and valve actuators

Paragon with 4 tube coil, i.e. separate cooling and heating coils

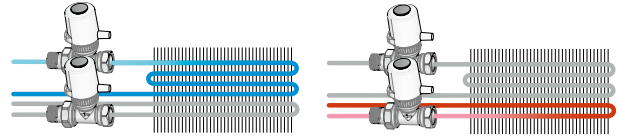

#### PARAGON Wall B (cooling and heating) with CCO valve

Paragon B with CCO valve Compact Change Over is used to utilise the whole coil of both cooling and heating.

Advantages:

- Faster conditioning of a room that has been left empty. High and consistent comfort
- Permits a higher cooling water temperature and lower heating water temperature, which gives lower operating costs for the chiller and heat pump, i.e. less environmental impact.

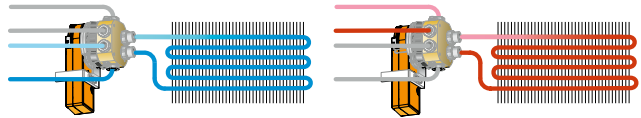

The URC1 room control system is used to control the CCO valve. For more information about the CCO valve, see the CCO product data sheet at [www.swegon.se](http://www.swegon.se)

#### PARAGON Wall A (cooling) with valve and valve actuator

Paragon A for cooling only. The capacity of the heat exchanger is utilised optimally by maximising the cooling circuit through the coil.

- The high output gives faster cooling of hotel rooms that have stood empty.

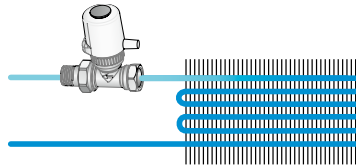



# Accessories

## Selectable factory-fitted options/accessories

Factory-fitted control equipment makes the installation work simple. All components are accessible from the back of the product.

### A selection of our optional factory-fitted extras:

Controller	PARAGON VAV RE
Actuator	PARAGON VAV SA
Valve cooling	SYST VDN 215 Straight valve
Valve heating	SYST VDN 215 Straight valve
Actuator cooling	ACTUATOR 24 V NC
Actuator heating	ACTUATOR 24 V NC
Pressure sensor	SYST PS
Condensation sensor	CG IV
"	WCD2
Temperature sensor	T-TG-1
Air quality sensor CO <sub>2</sub>	Detect Qa
Air quality sensor VOC	Detect VOC-2

### Upgrade kits

There are also a number of upgrade kits for upgrading from PARAGON VAV and to WISE Paragon

Upgrade kit WISE Paragon CU

Upgrade kit WISE Paragon SA

Control kit WISE Paragon Dew point

### In addition to the factory-installed options, loose accessories and kits (not factory-fitted) are also available:

Kits and accessories are mounted during installation.

Controller KIT	WISE PARAGON CU - Kit
Actuator motor KIT	WISE Paragon SA - Kit
Pressure sensor	SYST PS
Valve cooling	SYST VDN 215 Straight valve
Valve heating	SYST VDN 215 Straight valve
Actuator cooling	ACTUATOR 24 V NC
Actuator heating	ACTUATOR 24 V NC
Valve 6-way	CCO-kit
Condensation sensor	CG IV - Kit
	WCD2 - Kit
	WISE SMA Multi
Temperature sensor	T-TG-1
	WISE Temperature sensor PT1000
Air quality sensor	CO <sub>2</sub> -Kit, Detect Qa
	VOC-Kit, Detect VOC-2
Setpoint selector switch	LOCUS (wall)
Temp./Occupancy detector	VAV sensor (wall) - kit

# Accessories, factory-fitted

## Valve, cooling & heating

Factory fitted valves for cooling and heating.

The valve is mounted on the product and preset fully open.

Function	Type	Dim.	$K_v$ (m <sup>3</sup> /h)
Cooling/heating	VDN215	DN15 (1/2")	0.07-0.89

For more information about the valve, see the separate product data sheet on [www.swegon.com](http://www.swegon.com).



## Actuator cooling & heating, ACTUATORc 24 V NC

Factory fitted valve actuators for cooling and heating.

24V AC/DC, NC (Normally Closed).

For more information about the actuator, see the separate product data sheet on [www.swegon.com](http://www.swegon.com).



## Transformer, Power Adapt 20 VA

Transformer for the voltage supply of products.

Protective transformer with plug type F.

Input voltage 230 V 50-60 Hz

Output voltage 24 V AC

Power 20 VA

Double insulation

Enclosure IP33



## Condensation sensor WCD2

The detector operates at the dew point temperature rather than a fixed relative humidity value.

The dew-point is calculated from a temperature compensated RH element and an extremely accurate sensor element that is bound to the metal plate on the detector.

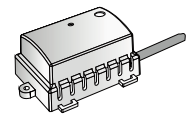

## Condensation sensor, CG IV

The condensation sensor is supplied fitted and connected from the factory. The actual sensor element consists of a circuit board with gold plated conductive paths that react when condensation occurs between these. When condensation arises, the cooling valve closes the incoming water flow to the product. When the condensation on the conductive paths has been wiped off, the cooling valve is permitted to open again.

The sensor is positioned on the coil fins by the cooling supply.

For more information about the condensation sensor, see the separate product data sheet on [www.swegon.com](http://www.swegon.com).

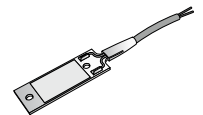

## CO<sub>2</sub> sensor. Detect Qa

Analogue carbon dioxide sensor that is mounted concealed in the product.

See separate product sheet at [www.swegon.com](http://www.swegon.com).

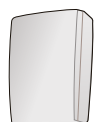

## VOC sensor Detect VOC

Modbus connected air quality sensor that is mounted concealed in the product.

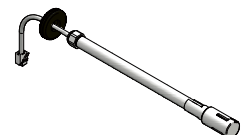

# Loose accessories

## Supply/extract air grille, PARAGON T-SG/RG

Front grille for PARAGON Wall, available for products with the length, 800, 1100, 1400 mm

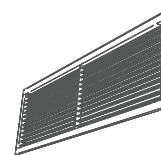

## Transformer, Power ADAPT 20 VA (ARV)

Input voltage 230 V, 50-60 Hz, Output voltage 24 V AC  
Power 20 VA, Enclosure IP33

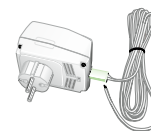

## Transformer, SYST TS-1

Double-insulated protective transformer 230 V, AC/24 V AC  
Input voltage 230 V, 50-60 Hz, Output voltage 24 V AC,  
Power 20 VA, Enclosure IP33

For more information, see the separate product data sheet on [www.swegon.com](http://www.swegon.com).

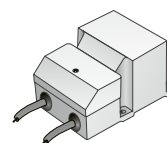

## Temperature sensor, T-TG-1

External temperature sensor. Used for example if the room temperature must be measured elsewhere than at the sensor module, or to measure the temperature of the main pipe in change-over systems.

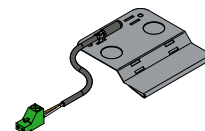

## Valve, SYST VDN215

Straight valves for cooling and heating.

VDN215 is preset fully open on  $K_v$  0.89.

Function	Type	Dim.	$K_v$ (m <sup>3</sup> /h)
Cooling/heating	VDN215	DN15 (1/2")	0.07-0.89

For more information about the valve, see the separate product data sheet on [www.swegon.com](http://www.swegon.com).



## 6-way valve, CCO

Compact Change Over, for maximum utilisation of the coil and thus high cooling and heating capacity.

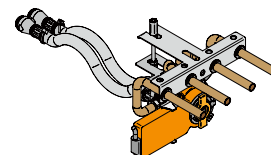

## Valve actuator, cooling & heating, ACTUATORc 24 V NC

Valve actuators for cooling and heating.

24V AC/DC, NC (Normally Closed).

For more information about the actuator, see the separate product data sheet on [www.swegon.com](http://www.swegon.com).



## Card switch, SYST SENSO II

Key card holder for hotel rooms.



## Sensor module, external

Rectangular sensor module with temperature and occupancy sensors for wall mounting

Always supplied with both a mounting frame for the most common junction boxes and a spacer frame for surface mounting.



## Room controller, LOCUS

Setpoint selector switch with built-in temperature sensor, designed for Swegon's products with a VAV controller (URC1). It has a digital, colour touch-display, where you can regulate the indoor climate by increasing or decreasing the setpoint temperature. You can also see air flows, pressure, VOC, CO<sub>2</sub> and alarms.



## Cable, SYST CABLE RJ12 6-LED.

Cable for the connection of an external sensor module to the controller or between sensor modules. Available in different standard lengths.



## Cable, CABLE CONVERTER USB-RJ12 (RS485)

Cable with integrated modem to connect a PC to the controller. Needed to run e.g. SWICCT or ModbusPoll.



## LINK Wise

Network cable for Modbus communication in the WISE system.

The cable conforms to EIA 485 standard. Shielded four conductor AWG 24, external diameter Ø 9.6 mm, Grey PVC. The cable is only supplied in reels of 500 m.



## Co<sub>2</sub> sensor. Detect Qa

Analogue carbon dioxide sensor that is mounted concealed in the product. See separate product sheet at [www.swegon.com](http://www.swegon.com).

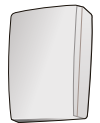

## VOC sensor Detect VOC

Modbus connected air quality sensor that is mounted concealed in the product.

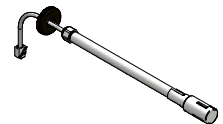

## Condensation sensor, WCD2

The detector operates at the dew point temperature rather than a fixed relative humidity value.

The dew-point is calculated from a temperature compensated RH element and an extremely accurate sensor element that is bound to the metal plate on the detector.

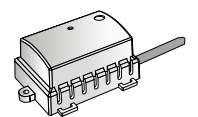

**Condensation sensor, CG IV**

The condensation sensor's sensor element consists of a circuit board with gold plated conductive paths that react when condensation occurs between these. When condensation arises, the cooling valve closes the incoming water flow to the product. When the condensation on the conductive paths has been wiped off, the cooling valve is permitted to open again.

Sensor is positioned on the coil fins by the cooling supply.

For more information about the condensation sensor, see the separate product data sheet on [www.swegon.com](http://www.swegon.com).

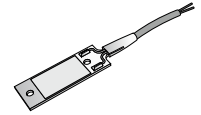

**Grille lock, PARAGON VAV T- GL**

Grille lock for fixing the position of the supply air grille.



**Assembly fitting, SYST MS M8**

For installation use the assembly fitting containing threaded rods, ceiling brackets and nuts to all four mounting brackets.



**Flexible connection hoses, SYST FH**

Flexible hoses are available with quick-fit, push-on couplings as well as clamping ring couplings for quick and simply connection. The hoses are also available in various lengths.

Note that compression ring couplings require support sleeves inside the pipes.

Flexible hoses also reduce the risk of movement in the piping system due to thermal expansion.

F1 = Clamping ring couplings at both ends.

F20 = Push-on couplings at both ends.

F30 = Push-on coupling at one end and union nut G20ID at the other end.

F4/F5 = Clamping ring coupling at one end and union nut with flat seal at the other end.

F40 = Push-on coupling at one end, union nut 90° at the other end.

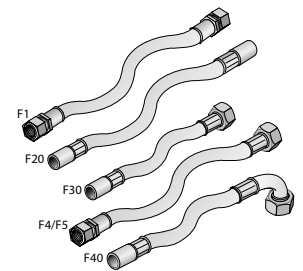

**Venting nipple, SYST AR-12**

A venting nipple is available as a complement to the flexible hoses with push-on couplings. The venting nipple fits directly in the push-on hose coupling and can be fitted in an instant.

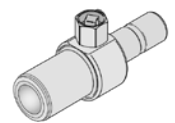

**Connection piece, air – insertion joint, SYST AD1**

SYST AD1 is used as an insertion joint between the product and the duct system. Ø125 mm.



**Connection piece, air, SYST CA**

90° duct bend

Ø125 mm.



# Accessory kits

## CG-IV-KIT

Condensation sensor CG-IV and assembly parts for retrofitting.

Condensation sensor's sensor element consists of a circuit board with gold plated conductive paths that react when condensation occurs between these. When condensation arises, the cooling valve closes the incoming water flow to the product. When the condensation on the conductive paths has been wiped off, the cooling valve opens again. The sensor is positioned on the coil fins by the cooling supply.

For more information about the condensation sensor, see the separate product data sheet and installation instructions on [www.swegon.com](http://www.swegon.com).

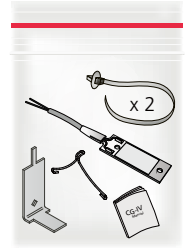

## WCD2-KIT

Condensation sensor WCD2 and assembly parts for retrofitting.

The detector operates at the dew point temperature rather than a fixed relative humidity value.

The dew-point is calculated from a temperature compensated RH element and an extremely accurate sensor element that is bound to the metal plate on the detector.

For more information about the condensation sensor, see the separate product data sheet and installation instructions on [www.swegon.com](http://www.swegon.com).

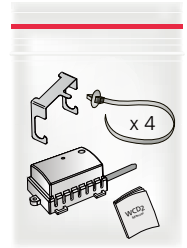

## SUPPLY AIR KIT-125

The supply air kit contains a sleeve and sound attenuator Ø125 mm.

Accessories must be completed through user configuration of one or more selectable properties on the product.

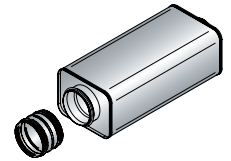

## Extract Air Kit VAV-REACT-125

Extract air kit for VAV containing a REACT Va Mb damper, control valve EXC and sound attenuator. Accessories must be completed through user configuration of one or more selectable properties on the product.

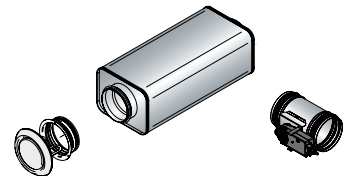

## Upgrade kit for WISE

### UPGRADE KITS WISE PARAGON CU

Control kit for upgrading to WISE

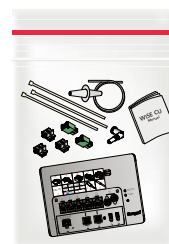

### UPGRADE KIT WISE PARAGON SA

Motor kit and control cable for upgrading to WISE

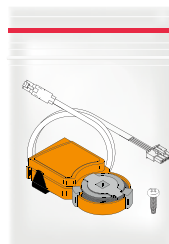

### Upgrade kit WISE CG-IV-KIT

The upgrade kit includes condensation sensor and assembly parts

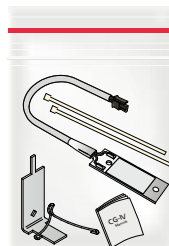

### Upgrade kit WISE temperature sensor

The upgrade kit includes temperature sensor TG3 PT-1000



### Upgrade kit WISE SMA Multi

The upgrade kit includes WISE SMA Multi incl. RJ12 cable and assembly plate.



# Dimensions and weight

## Weight

### PARAGON Wall VAV 800

Length mm	Type	Dim. Ø	Dry weight* (kg)		Water volume (l)	
			Without grille	incl. grille	cooling	heating
800 R	A	125	17.4	19.6	1.39	
800 L	A	125	17.4	19.6	1.38	
800 R	B	125	17.4	19.6	1.39	0.38
800 L	B	125	17.4	19.6	1.38	0.37
800 R	X	125	17.4	19.6	1.39	
800 L	X	125	17.4	19.6	1.38	

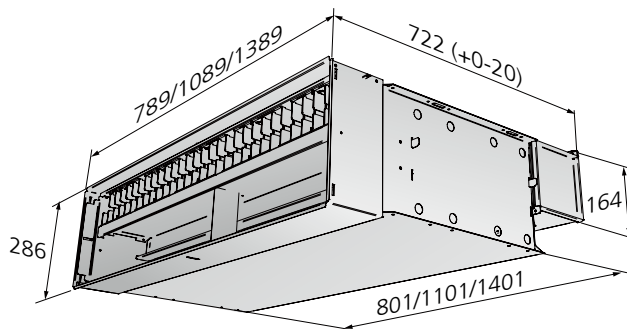

Figure 24. Dimensional drawing without grille.

### PARAGON Wall VAV 1100

Length mm	Type	Dim. Ø	Dry weight* (kg)		Water volume (l)	
			Without grille	incl. grille	cooling	heating
1100 R	A	125	22.6	25.5	1.93	
1100 L	A	125	22.6	25.5	1.92	
1100 R	B	125	22.6	25.5	1.93	0.52
1100 L	B	125	22.6	25.5	1.92	0.51
1100 R	X	125	22.6	25.5	1.93	
1100 L	X	125	22.6	25.5	1.92	

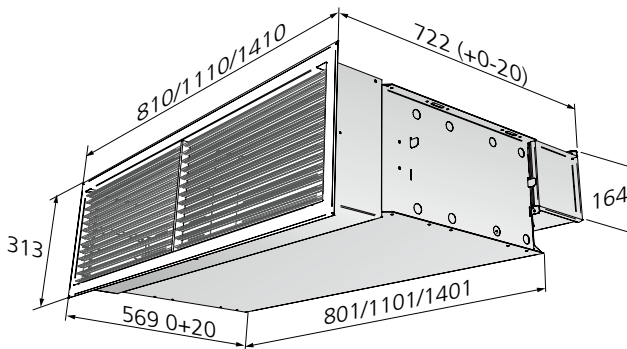

Figure 25. Dimensional drawing with grille.

### PARAGON Wall VAV 1400

Length mm	Type	Dim. Ø	Dry weight* (kg)		Water volume (l)	
			Without grille	Incl. grille	cooling	heating
1400 R	A	125	27.6	31.2	2.47	
1400 L	A	125	27.6	31.2	2.46	
1400 R	B	125	27.6	31.2	2.47	0.65
1400 L	B	125	27.6	31.2	2.46	0.64
1400 R	X	125	27.6	31.2	2.47	
1400 L	X	125	27.6	31.2	2.46	

\*Added weight for:  
Control equipment: 0.80 kg  
Actuator: 0.28 kg



# Specification

## Specification

Type PARAGON Wall VAV comfort module for cooling, heating, ventilation and control. As standard, factory fitted components are included for plug & play installation.

## Delivery demarcation

Swegon's limits of supply are at the connection points for water.

At these connection points, the RE pipework contractor connects to plain pipe end and/or male threads towards valves, fills the system, bleeds it and tests the pressure in the circuits.

The ventilation contractor connects to the duct connections with dimensions as specified on the basic size drawing in the section "Dimensions".

EE electrical equipment contractor provides a 24 V AC network power supply or earthed 230 V outlets for a transformer, as well as a junction box, if required, installed in a wall for a room thermostat.

The building contractor cuts the openings in corridor wall for the supply air duct, in the interior wall and suspended ceiling for the supply air and extract air grilles and in the bathroom ceiling for the extract air duct.

The electrical contractor connects the power (24V) and signal cables to the connection terminals with spring-loaded snap-in connections.

Maximum cable cross section 2.5 mm<sup>2</sup>. For safe operation, we recommend cable ends with ferrules.

## Maintenance

Since the PARAGON Wall VAV operates without any built-in fan, without filter and without a drainage system, very little maintenance is required.

In an office, it is normally sufficient to vacuum clean the back side of the coil once every two years to remove loose dust. A simple visual inspection of connections and wiping the supply/extract air grille with a damp cloth is also recommended. Avoid aggressive cleaning agents which may harm painted surfaces. Normally a mild soap or alcohol solution is fully adequate for cleaning. Note that the dry operation without condensation minimises the risk of bacteria growth that otherwise is occurs in wet systems.

The maintenance requirement for PARAGON Wall VAV is low, as it is normally a dust-free environment, which is why the maintenance interval is so long.

## Ordering key PARAGON Wall

<b>PARAGON Wall VAV</b>	<b>d</b>	<b>aaaa-</b>	<b>b-</b>	<b>cccc-</b>	<b>125</b>
Version:					
Length (mm)					
800, 1100 and 1400					
Function:					
A = Cooling					
B = Cooling and heating (water)					
Connection side - water (seen from the back of the product)					
R - Right					
L - Left					
Air connection					
Ø 125					

## Factory-fitted optional extras

Control unit/Controller	PARAGON VAV RE
Motor	PARAGON VAV SA
Valve cooling	SYST VDN 215 Straight valve
Valve heating	SYST VDN 215 Straight valve
Actuator cooling	ACTUATOR d 24V NC
Actuator heating	ACTUATOR d 24V NC
Condensation sensor	CG IV WCD2
Temperature sensor	T-TG-1
Air quality sensor CO <sub>2</sub>	Detect Qa
Air quality sensor VOC	Detect VOC-2

**Available to order, kit and accessories**

**In addition to the factory-installed options, loose accessories and kits (not factory-fitted) are also available:**

Kits and accessories are easily mounted during installation

**A selection of our optional kits and accessories:**

Controller KIT	PARAGON VAV RE - Kit
"	WISE PARAGON CU - Kit
Actuator motor KIT	PARAGON VAV SA - Kit
"	WISE Paragon SA - Kit
Valve cooling	SYST VDN 215 Straight valve
Valve heating	SYST VDN 215 Straight valve
Actuator cooling	ACTUATOR 24 V NC
Actuator heating	ACTUATOR 24 V NC
Valve 6-way	CCO
Condensation sensor	CG IV
"	WCD2
Temperature sensor,	T-TG-1
Occupancy sensor - KIT	
Air quality,	WISE SMA Multi
Air quality, CO2-KIT	CO <sub>2</sub> Detect Qa - kit
Air quality, VOC-KIT	DETECT VOC-2 - kit
Condensation sensor KIT	CG IV - kit
"	WCD2 - kit
Pressure sensor	SYST PS
Sensor module	VAV sensor module
"	WISE SMB
Room controller	LOCUS
Supply air kit	Supply Air Kit 125
Extract air kit	Extract Air kit VAV-REACT-125

**Ordering Key, Accessories**

Grille	PARAGON Wall d T-	SG/RG-	bbbb
Type:			
SG/RG = Supply/extract air grille			
Product length (mm):			
800, 1100, 1400			

Assembly fitting	SYST MS M8	aaaa-	b
Length threaded rod (mm):			
200; 500; 1000			
Type:			
1=One threaded rod			
2=Two threaded rods and one thread lock			

Flexible connection hose, (x1)	SYST FH F1-	aaa-	12
Compression ring (Ø12 mm) against pipe at both ends (excl. support sleeves)			
Length (mm):			
300, 500, 700			

Flexible connection hose, (x1)	SYST FH F20-	aaa-	12
Quick-connector push-on (Ø12 mm) against pipe at both ends			
Length (mm):			
275, 475, 675			

Flexible connection hose, (x1)	SYST FH F30-	aaa-	12
Quick-fit coupling, push-on (12 mm dia.) against pipe on one end, G20ID sleeve nut on the other end.			
Length (mm):			
200, 400, 600			

Condensation sensor		aaaa	
WCD2 proactive condensation control			
CG-IV reactive condensation control			

Room controller	LOCUS	a-	b
Version:			
Frame colour:			
W = white			
B = black			

**Accessory kits:**

- Controller KIT WISE PARAGON CU xx items
- Controller KIT LUNA RE xx items
- Actuator motor KIT WISE PARAGON SA xx items
- Condensation sensor KIT for retrofitting  
Condensation sensor CG IV-KIT, xx items
- Condensation sensor for retrofitting, WCD2-KIT, xx items
- Temp. sensor, T-TG1-KIT, xx items
- Temp. sensor, Dew-point KIT WISE Paragon, xx items
- Air quality sensor, CO2-Kit, Detect Qa, xx items
- Air quality sensor, VOC-Kit, DETECT VOC-2
- Air quality, WISE SMA Multi, xx items
- Supply Air Kit-125, xx items
- Extract Air Kit VAV-REACT-125, xx items

**Accessories:**

- Supply/extract air grille, PARAGON Wall d-T-SG/RG-aaaa, xx items
- Grille lock, PARAGON T-GL xx items
- Valve cooling SYST VDN 215 xx items
- Valve heating SYST VDN 215, xx items
- Actuator cooling ACTUATORc 24 V NC, xx items
- Actuator heating ACTUATOR c 24 V NC, xx items
- 6-way valve, CCO, xx items
- Transformer, POWER Adapt 20 VA, xx items
- Transformer, SYST TS-1, xx items
- Pressure sensor, SYST PS, xx items
- Room controller/Setpoint selector switch, LOCUS, xx items
- Sensor module, VAV sensor module, xx items
- Card switch, SYST SENSO II, xx items
- Assembly piece, SYST MS M8 aaaa-b
- ADC for subsequent installation, SYST ADC-2-105, xx items
- Cable adapter, ADAPTER RJ12-WIRE, xx items
- Flexible connection hose, SYST FH F1 aaa- 12 xx pcs.
- Flexible connection hose, SYST FH F20 aaa- 12 xx pcs.
- Flexible connection hose, SYST FH F30 aaa- 12 xx pcs.
- Venting nipple, push-on, SYST AR-12, xx items
- Connection piece, air – nipple, SYST AD1-aaa, xx items
- Connection piece, air (90°elbow), SYST CA-aaa-90, xx items

etc.

Specify the quantities individually or with reference to the drawing.

## Specification text

Example of a specification text according to VVS AMA.  
PCT.312 Duct connected chilled beams.

KB XX

Swegon's PARAGON Wall comfort module that supplies air via a common supply air and recirculated air grille.

For rear edge installation in a wall or ceiling, with the following functions:

- Waterborne cooling
- Waterborne heating
- Ventilation
- Comfort guarantee ADC with adjustable function +-30 degrees
- Ø125 mm duct connection
- Coil and any control equipment are accessible via the rear of the product
- Cleanable
- Fixed measurement tapping with hose
- Contractor demarcation at connection point for water and air as in outline drawing.
- At the points of connection the pipe contractor connects to 12 mm plain pipe end after which the ventilation contractor connects the Ø125 mm insertion piece (sleeve).
- The pipe contractor fills, bleeds, tests the pressure and assumes responsibility for the design water flows reaching each branch of the system and the unit.
- The ventilation contractor conducts initial commissioning of the airflows
- Eurovent certified
- Grilles in standard colour RAL 9003

**Contractor demarcation at connection point for water and air as in outline drawing.**

- At the points of connection the pipe contractor connects to 12 mm plain pipe end after which the ventilation contractor connects the Ø125 mm insertion piece (sleeve).
- The pipe contractor fills, bleeds, tests the pressure and assumes responsibility for the design water flows reaching each branch of the system and the unit.
- The ventilation contractor conducts initial commissioning of the air flows