

OMICRON Zero S4

50÷240 kW



General

High efficiency multi-functional units for large 4-pipes system with refrigerant R290

Configurations

SLN: super low noise version

Strengths

- ▶ Refrigerant R290 - GWP≈0. The refrigerant is a pure natural fluid.
- ▶ Reduced refrigerant charge
- ▶ Extended operating limits: the ideal solution to replace boilers. High efficiency in all operating modes and working conditions
- ▶ Independent defrosting cycles for each circuit with evolved operating logic
- ▶ Eurovent certification

BlueBox 
by Swegon

OMICRON Zero S4	
Application and operating principle	5
OMICRON Zero S4	
Product description	6
Refrigerant	6
Versions	10
Description of accessories	12
Refrigerant circuit accessories	12
Fan accessories	13
Hydraulic circuit accessories	14
Flowzer options	15
Electrical accessories	29
Network accessories	33
Other accessories	36
Technical specifications	38
Ecodesign	44
Electrical specifications	50
User-side exchanger flow rate fields	52
Operating limits	53
Operating limits	55
Noise levels	56
Installation advice	58
Water characteristics	58
Glycol mixtures	58
Minimum water content in the system	59
Installation site	60
Installations that require the use of treated coils	61
Aeraulic head losses and options available for the ventilating section	62
Installation site	63
Installation types	64
Definitions	65
Class III hydronic unit installations in open air environments	66
Hydraulic Connections	69
Guidelines for the risk assessment	70
Applicable standards and regulations and reference documents	72
Installation risk assessment	73
Suggestions for conducting and drawing up the risk assessment	77
Dimensional diagrams	81



OMICRON Zero S4

APPLICATION AND OPERATING PRINCIPLE

Multi-purpose units are machines designed for use in all applications where there may be a simultaneous and independent demand for hot and cold water production.

In particular, this occurs for all systems that use 4-pipe terminals, such as for example dual aspect buildings, buildings with large glazed surfaces or high-insulation buildings with non-homogeneous crowding levels.

The 4-pipe multi-purpose unit is able to meet simultaneous and independent heat loads of opposite sign, with the advantage of working in heat recovery operation: whenever there is a simultaneous demand for cooling and heating, the multi-purpose unit will work in recovery mode, and move the thermal energy from rooms that need to be cooled to those that need to be heated.

If the two heat loads are not balanced, then the controller works in mixed mode to recover as much thermal energy as possible and use the air exchanger as heat source with which to exchange the missing amount of capacity for meeting both demands of the system.

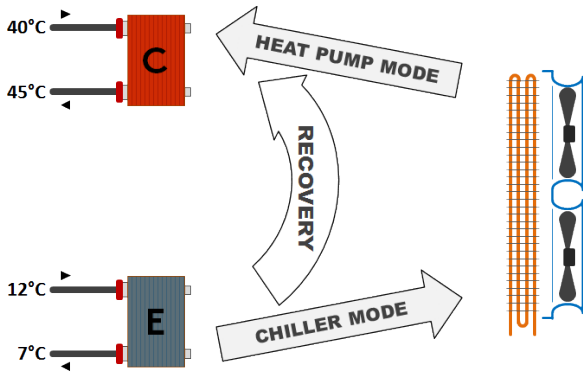

The 4-pipe multi-purpose unit can therefore work indirectly all year round to meet all the thermal and cooling energy demands of the system and is therefore an alternative to conventional systems based on the chiller/boiler combination with the additional non-negligible advantage of waste heat recovery.

Depending on the various scenarios that can occur over the span of a day, the multi-purpose unit can work with different modes and change from one to another fully automatically.

Cooling mode

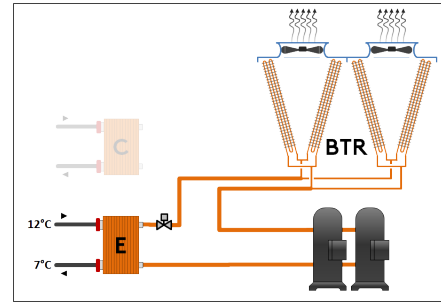

The unit works in this mode when the system requires only cold water production. It uses the finned coil "BTR" as source-side heat exchanger and produces chilled water at exchanger "E", connected to the circuit dedicated to water distribution for only air conditioning in the building.

OMICRON Zero S4

Heating mode

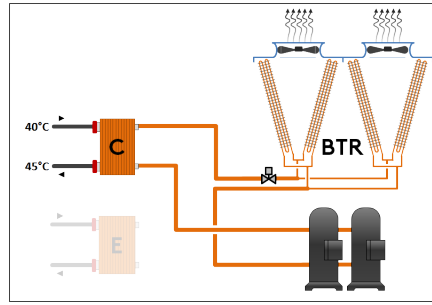

The unit works in this mode when the system requires only heating. It uses the finned coil "BTR" as source-side heat exchanger and produces hot water at exchanger "C", connected to the circuit dedicated to water distribution for only heating in the building.

Cooling + heating mode

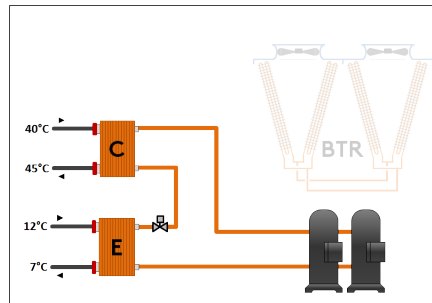

When there is a simultaneous demand for hot water and cold water in the system, the multi-purpose unit behaves like a water/water heat pump, and manages condensation on exchanger "C" and evaporation on exchanger "E" and therefore works simultaneously on the two hydronic circuits of the system.

The change from one configuration to another takes place fully automatically while trying to optimize the energy spent based on the demand from users.

Since all the units are also multi-circuit, the recovery mode can be used on one circuit while the other works in cooling or heating mode, and this is essential to meet unbalanced hot/cold load demands and in any case obtain the maximum level of energy recovery.

PRODUCT DESCRIPTION

Refrigerant

OMICRON Zero models are available with R290 refrigerant.

The use of R290 refrigerant is indicated by the acronym "Zero" which indicates a GWP level close to 0.

Refrigerant R290 GWP(Global Warming Potential) \approx 0*
ODP (Ozone Depletion Potential) 0

The refrigerant is a pure natural fluid.

R290 is classified as group 1 fluid according to PED.

It is also classified as A3 according to ASHRAE standard 34:

- non-toxic;
- Highly flammable.

The excellent GWP value may be an advantage in projects where:

- min. targets are adopted for the containment of the environmental footprint;
- it is possible to receive incentives or other benefits that are applicable in some countries or are connected to specific plant design criteria.

(*) GWP (AR6), pursuant to IPCC VI, evaluated over a span of 100 years.

STRUCTURE

The body is modular with a load-bearing frame, made of galvanized sheet-iron coated with polyester powder RAL 5017/7035 which makes it highly resistant to weather conditions.

COMPRESSORS

The compressors are hermetic orbiting spiral scroll compressors, each fitted with oil level sight glass.

Depending on the model, there are the following compressor configurations:

- the models with two compressors (x.2) have 1 compressor for each circuit.
- models with four compressors (x.4) have 2 compressors connected in tandem for each circuit.
- models with six compressors (x.6) have 3 compressors connected in trio for each circuit.

For units with two or three compressors, there is also an oil equalization line.

All the compressors are fitted with crankcase heating device.

FANS

The fans are axial fans, directly coupled to a three-phase 6-pole electric motor, with integrated thermal overload protection (Klixon®) and IP 54 protection rating.

The fan includes the shroud, designed to optimize its efficiency and reduce noise emission to a minimum, and the safety guard.

SOURCE-SIDE HEAT EXCHANGER

The exchangers are made with finned pack coils with copper tubes and aluminium fins.

The coil/fan sections are made so as to be completely separate between the refrigerant circuits. This allows management of independent, never simultaneous, defrost cycles.

The coils have an increased fin pitch to reduce frost formation and to facilitate the outflow of condensed water during defrosting.

Hydrophilic treatment as standard

Hydrophilic coating is a special treatment applied to the finned coils (source side) in heat pump units to facilitate drainage of the condensate that forms on the surface of the heat exchanger.

This treatment causes the water vapour to form a film of condensate on the surfaces of the fins, which, thanks to the low surface tension, drains rapidly into the drip tray (if present) positioned beneath the coils.

Compared to traditional finned coils in untreated aluminium, the hydrophilic coating delays the necessity to defrost the heat exchanger, thereby extending the interval between defrosting cycles and boosting its efficiency and, hence, improving the performance and energy consumption of the heat pump.

In the absence of the hydrophilic coating, the humidity present in the air condenses in the form of drops, which, due to the greater friction, are more likely to remain trapped within the coil pack, limiting the passage of air and impacting negatively on heat exchange, this causes the surface temperature to drop further (due to a decrease in the evaporation temperature), facilitating the formation of ice and reducing the interval between defrosting cycles. This effect is even more pronounced in the case of installations in particularly windy areas.

The following is a comparison between a standard finned coil pack and a pack treated with the hydrophilic coating at the end of the defrosting cycle, on the same unit, with an external DB air temperature of -2°C . Note the residual presence of water droplets on the untreated heat exchanger, as compared to perfectly clean surface of the treated unit.



Standard, untreated coil pack

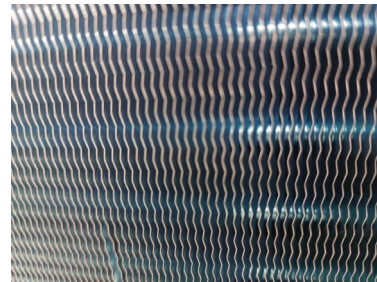

Coil pack with hydrophilic coating

While it is not specifically designed for use in marine environments, an additional advantage of the hydrophilic coating is its greater resistance to salt fog conditions with respect to untreated aluminium.

To avoid compromising the benefits of applying the treatment, or prevent additional problems from arising in the case of untreated units, it is also necessary to ensure the condensed water is drained correctly, so as to prevent the formation of ice at the base of the heat exchanger, which could cause it to extend to the entire coil pack, compromising the efficiency of the defrosting cycle, and hence the operation and performance of the unit.

With this in mind, the following accessories are available:

- RAV_anti-freeze element (available either as standard or optional, depending on the series/model of the unit)
- RAM_high power anti-freeze element
- KTC_drip tray connector tube kit (for units equipped with drip tray)

The hydrophilic coating is not compatible with other treatments included in the price list.

To protect the exchangers from corrosion and ensure optimal operation of the unit, we advise following the recommendations given in the user, installation and maintenance manual for cleaning the coils. For installations within a kilometre of the coast, use of the accessory is strongly recommended Coil treated with anti-corrosion paints.

COLD USER-SIDE HEAT EXCHANGER

The exchanger is a dual circuit, braze-welded stainless steel plate heat exchanger, insulated with a shroud of closed-cell insulating material.

HOT USER-SIDE HEAT EXCHANGER

The exchanger is a dual circuit, braze-welded stainless steel plate heat exchanger, insulated with a shroud of closed-cell insulating material.

REFRIGERANT CIRCUIT

Each refrigerant circuit of the basic unit comprises:

- 4-way reversing valve
- delivery shut-off valve
- suction shut-off valve
- liquid receiver
- charging valves
- liquid sight glass
- dehydrating filter
- 2x electronically-controlled thermostatic expansion valves
- Extra Recovery "XR" Function
- high and low pressure switches
- suction liquid separator

The copper pipes are sized with increased thicknesses in order to ensure greater reliability and durability over time. The pipes of the circuit and the exchanger are insulated with extruded closed-cell expanded elastomer.

The refrigeration circuit is enclosed in a compartment that contains an ATEX certified leak sensor and an ATEX certified extraction fan.

The hydronic module, if present, is also enclosed in the compartment that contains the ATEX certified leak sensor and the ATEX certified extraction fan.

CONTROLLO BLUETHINK

Main controller functions

The microprocessor control allows the following functions:

- water temperature control, with control of water at the inlet on the cold exchanger and on the hot exchanger
- freeze protection
- compressor timings
- automatic rotation of compressor starting sequence

- automatic rotation of compressor starting sequence
- recording of the alarm log
- sliding defrost management
- management of independent, never simultaneous, defrosts on the various refrigerant circuits
- digital input for general ON/OFF
- digital input for cold circuit ON/OFF
- digital input for hot circuit ON/OFF
- RS485 serial port with Modbus protocol
- Ethernet serial port with Modbus protocol and integrated web server preloaded web page

For further details on available functions and on displayed information, you can refer to the specific documentation of the control.

By default, the serial connections present as standard are enabled only for reading from BMS. Enabling of writing from BMS is to be requested when ordering.

Main functions of the webserver

As standard, the Bluethink controller integrates a web-server with a preloaded web page that is accessed via password.

The web page allows the following functions to be carried out (some of these are available only for users with advanced level rights):

- display of the main information on the unit, such as serial n°, size, type of refrigerant
- display of the general status of the machine: water inlet and outlet temperatures, external air temperature, operating mode, evaporating and condensing pressures, suction and discharge temperatures
- display of the status of compressors, fans, pumps, electronic expansion valves
- display in real time of the graphs of the main quantities
- display of the graphs of logged quantities
- display of alarm log
- display of the status of all the I/Os of the controller
- management of users on several levels
- remote ON/OFF
- remote set point change
- remote time band change
- remote summer winter mode selection

Human-Machine Interface

The control has a graphic display that allows the following information to be displayed:

- water inlet and outlet temperature of the cold circuit
- water inlet and outlet temperature of the hot circuit
- set temperature and differential set points
- description of alarms
- hour meter of operation and number of start-ups of the unit, the compressors and the pumps (if present)
- high and low pressure values, and relevant condensing and evaporating temperatures
- external air temperature
- superheating at compressor suction.

ELECTRICAL CONTROL PANEL

The electrical control panel is made in a painted galvanized sheet-iron box with forced ventilation and IP54 protection rating.

The electrical panel is made following the EN60204-1 standard.

The electrical panel is separated from the compressor compartment.

The electrical control panel of the basic unit comprises:

- general disconnect switch three-phase line
- fuses to protect the compressors, fans and auxiliary circuits
- fan contactors
- phase-cutting fan speed adjuster
- thermal magnetic circuit breakers for pumps (if present)
- phase monitor
- potential-free general alarm contacts
- single potential free operating contacts for compressors, fans and pumps (when present)
- digital input for general ON/OFF
- summer/winter selection by digital input
- external air temperature probe
- microprocessor controller with display accessible from the outside

All the electrical cables inside the panel are numbered and the terminal board dedicated to the customer's connections is coloured orange so that it can be quickly identified in the panel.

The unit power supply is 400V/3~+N/ 50Hz for all models.

Management of defrost cycles

For defrost management, the control of the unit uses a sliding intervention threshold, depending on the pressures inside the unit and the external air temperature. By putting together all this information, the control can identify the presence of ice on the coil and activates the defrosting sequence only when necessary, so as to maximize the energy efficiency of the unit.

Sliding management of the defrost threshold ensures that, as the absolute humidity of outdoor air decreases, the frequency of the defrost cycles gradually decreases because they are carried out only when the ice formed on the coil actually penalizes performance.

CONTROLS AND SAFETY DEVICES

All the units are fitted with the following control and safety components:

- high pressure switch with manual reset
- high pressure safety device with automatic reset, for a limited number of occurrences, managed by the controller
- low pressure safety device with automatic reset and limited tripping managed by the controller
- high pressure safety valves
- antifreeze probe at the outlet of the user-side heat exchangers
- differential pressure switch already fitted on the user-side heat exchangers
- overtemperature protection for compressors and fans

TESTING

All the units are factory-tested and supplied complete with oil and refrigerant.

PACKAGING

There are yellow lifting brackets at the base of the unit to allow lifting with lifting beam.

The unit is wrapped in a protective transparent polyethylene stretch film.

VERSIONS

OMICRON Zero S4 SLN

These units involve the use of fans with speed adjuster calibrated with a reduced air flow rate. The speed reduction of the fans is such that, under nominal operating conditions in chiller mode, the air flow rate and noise level are lower than those of the standard version of the unit.

In any case, the use of the speed adjuster to reduce the air flow rate allows rotation of the fans at maximum speed when external air temperature conditions are particularly critical and therefore guarantees the same operating limits as the high efficiency versions.

In heat pump mode, the fans always operate at 100% speed and therefore guarantee the same performance levels as the high efficiency version.

HYDRAULIC MODULES

All units can be fitted with hydraulic module in various configurations:

- /1P/1R: hydraulic module with one pump on the cold circuit and one pump on the hot circuit
- /2P/2R: hydraulic module with two pumps on the cold circuit and two pumps on the hot circuit

The hydraulic modules with one pump per circuit (/1P/1R) have:

- one pump on the cooling circuit and one pump on the heating circuit
- a gate valve on the delivery side of each pump

The hydraulic modules with two pumps per circuit (/2P/2R) have:

- two pumps on the cooling circuit and two pumps on the heating circuit
- a check valve on the delivery side of each pump

In the version with 2 pumps, these are always with one on standby while the other is working. Switching over between the pumps is automatic and is done by time (to balance the hours of operation of each one) or in the event of failure.

CERTIFICATIONS AND REFERENCE STANDARDS

The manufacturer has implemented and keeps the Management Systems listed below and it is certified against them:

- Quality Management System according to standard UNI EN ISO 9000;
- Environmental Management System according to standard UNI EN ISO 14000;
- Health and Safety Management System according to standard BS OHSAS 18000 (as converted into UNI EN ISO 45000).

These management systems ensure that the company puts in place any and all actions and initiatives to define and monitor the standards defined by its Management, which are stated in its Quality, Environmental and Safety policies.

To meet the safety requirements, the unit was designed and manufactured in compliance with the directives and product regulations below:

- PED Directive: safety criteria to be followed when designing pressure equipment;
- Machinery Directive: safety criteria to be followed when designing machinery;
- Low Voltage Directive: safety criteria to be followed when designing electrical machine parts;
- Electromagnetic Compatibility Directive: electromagnetic compatibility criteria to be followed when designing electrical machine parts;
- WEEE Directive: criteria for product management at the end of its life cycle as waste with a view to environmental protection.

The units are manufactured, tested and checked with reference to the European standards specified in the Declaration of CE Conformity, in accordance with the requirements and procedures of our Quality System.

The transport, installation, use and storage of units with flammable refrigerants (A3 according to ASHRAE 34 standard) must meet European standards and regulations and local regulations where applicable.

For further details, please refer to the "Instruction manual for operation and maintenance".

Responsibilities and exclusive duties of the installation manager:

- to carry out a specific risk assessment according to the European regulations/standards above and/or the local laws in order to define the necessary measures for conformity;
- to comply with the requirements and to take the measures resulting from the outcomes of the risk assessment, pursuant to the relevant regulations and standards.

DESCRIPTION OF ACCESSORIES

Refrigerant circuit accessories

Some accessories may be incompatible with each other even if not expressly indicated.

BK Brine Kit

This accessory is compulsory if a water temperature set point lower than +5°C is used (if the unit is provided with double set point or variable set point, the lower set point is considered).

The accessory consists of increased insulation and suitable sizing and calibration of some components.

The inlet and outlet temperatures of the user-side exchanger must be given on ordering to allow correct setting of the alarm parameters and verification of the sizing of the expansion valve.

The cooling set point can then be changed by the customer in an interval that, compared to the set point given on ordering, ranges from -1K up to the maximum temperature allowed by the above-stated operating limits.

The unit will be optimized to work at the set point temperature given on ordering. For different set points, the cooling capacity provided and the level of efficiency of the machine could decrease and move away from these conditions.

DVS Double safety valve

With this accessory, instead of each individual safety valve per circuit, there is a "candelabrum" with two safety valves and a diverter valve for choosing the valve in operation. This allows the safety valves to be replaced without having to drain the machine and without having to stop it.

MAFR Pressure gauges

The operating pressures of each circuit of the unit can be displayed on the control by accessing the relevant screens. Also, the machine can be fitted with pressure gauges (two for each circuit) installed in a clearly visible position. These allow reading in real time of the working pressures of the refrigerant gas on the low pressure side and on the high pressure side of each refrigerant circuit.

RG Fan speed adjuster (S)

The control manages the speed of the fans through a phase cutting speed adjuster, in order to optimize the operating conditions and efficiency of the unit.

For units equipped with EC fans, the same function is carried out using the electronically commutated motor of the fans and is supplied as standard.

This option is standard.

RPR Refrigerant leak detector

With this accessory, a refrigerant leak detector is placed inside each compressor compartment. Detection of a refrigerant leak is managed by the controller through a specific alarm and display of a specific icon on the display of the controller. This alarm stops the unit.

This option is standard.

RUB Compressor suction and delivery valves

The valves situated on the delivery side and on the suction side of the compressors allow the compressor to be isolated from the rest of the refrigerant circuit, so making the maintenance operations quicker and less invasive

Fan accessories

VEC EC fans

With this accessory, EC fans, with electronically commutated brushless motor, are used for the ventilating section. These guarantee very high efficiency levels for all working conditions and allow a 15% saving on the power absorbed by each fan working at full capacity.

Also, through a 0-10V analogue signal sent to each fan, the microprocessor carries out condensation/evaporation control by continuous adjustment of the air flow rate as the external air temperature changes, with a further reduction in electrical absorption and noise emission.

For further details, see the dedicated chapter: "Aeraulic head losses and options available for the fan section".

VEM Oversize EC fans

The increased EC fans allow to obtain the same benefits as EC fans and in addition allow to have a residual useful head of about 100Pa.

For further details, see the dedicated chapter: "Aeraulic head losses and options available for the fan section".

Hydraulic circuit accessories

RA Antifreeze heater

These are electric heaters inserted on the user-side heat exchanger, on the pumps and in the tank (depending on the configuration of the machine) to prevent damage to the hydraulic components due to ice formation during periods when the machine is stopped.

The antifreeze heater is present as standard on both user-side heat exchangers.

FLUS Flow switches on both hydraulic circuits (in place of water differential pressure switches)

As an alternative to the differential pressure switch (standard flow sensor), it is possible to request the paddle flow switch as accessory. This detects when there is no water flow to the user-side exchanger and sends a signal to the control of the unit that will stop the compressors to prevent damage to the exchangers.

Application of this accessory is compulsory for units that use non-glycol water and work with a yearly cycle where external air temperatures are zero or below.

The flow switch is supplied loose (installation by the customer) and replaces the water differential pressure switch (standard).

V3MC 3-way modulating valve on hot circuit

The accessory involves the supply of a 3-way modulating valve to be inserted on the hot circuit in order to check that the temperature of the water entering the exchanger is always higher than the minimum allowed.

Flowzer options

Our range of Flowzer options offers flexible and scalable solutions to set the speed of pumps in the system with a view to optimising and reducing energy consumption. Different types of control modes are offered based on the system and application type:

- FLOWZER VP - Inverter for manual pump adjustment
- FLOWZER VD - control of available pump discharge head for variable flow systems without monitoring the flow rate limits;
- FLOWZER VDE - flow rate control to keep the flow rate constant as the external working conditions of the system change;
- FLOWZER VDT - flow rate control with constant TD (difference between input and output temperature in the heat exchanger on the user side) in variable flow pumps, without monitoring the flow rate limits;
- FLOWZER VFPP - automatic management of variable flow rate in systems with one single primary circuit and a bypass valve;
- FLOWZER VPS - automatic management of variable flow rate, including balancing of flow rates between primary and secondary circuits;
- flowzer vps with TD-based control - automatic management of variable flow rate, including control with constant TD (difference between input and output temperature in the heat exchanger on the user side) in systems featuring both the primary and secondary circuits.

The tables below summarise the main system diagrams and show the application type and advantages/disadvantages offered by each solution. Each individual option is illustrated and explained individually in the next pages.

The hydraulic diagrams in this document are for exemplification purposes only and their main function is to help the reader understand the type of machines and devices the controller can manage. For a more technical evaluation of the system, please refer to the dedicated manual.

Constant flow system			
	Application	Advantages	Disadvantages
Flowzer VP	Ideal for constant flow systems The option is given to set two different speeds: one for heating and one for cooling mode or one for chiller and one for FC mode. This solution replaces the 2-way regulating valve.	<ul style="list-style-type: none"> - Increased efficiency: increased "REAL" EER of the unit installed, considering the power consumption of the pumps in real installation conditions and in real operating conditions. - Reduced installation times and costs: quick setup of water flow using the display. 	This solution doesn't allow to save energy in the pump under part load conditions, due to the possibility to only set two frequency values in the inverter.
Flowzer VDE	Ideal for constant flow systems to keep the water flow to the heat exchanger constant under all conditions	<ul style="list-style-type: none"> - Plug&Play: provides for easy and flexible implementation as it is not supplied with options to be fitted therefore allows for quick commissioning. 	This solution is less efficient as losses in the heat exchanger are kept constant under all conditions (including in cases when they may be reduced).

FLOWZER VP

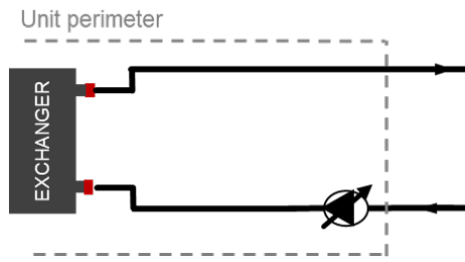

FLOWZER VDE

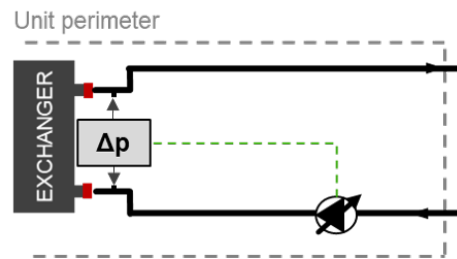

Variable flow system featuring primary and secondary circuits

	Application	Advantages	Disadvantages
Flowzer VPS	Ideal for all systems featuring a primary and a secondary circuit divided by a hydraulic bypass branch	<ul style="list-style-type: none"> - Energy saving: the energy consumption during pumping operations can be cut down to 55% if compared with a traditional system - Enhanced comfort: correct balancing between primary and secondary loop 	Only recommended in systems featuring a primary and a secondary circuit divided by a bypass pipe; not flexible for other applications
Flowzer VDT	Ideal for systems featuring similar users or users with similar operating conditions. It is recommended in structured systems in which the client has third-party systems to control the min. and max. flow rate.	<ul style="list-style-type: none"> - Plug&Play: provides for easy and flexible implementation as it is not supplied with options to be fitted and for quick commissioning. 	Risk of over- or underflow for some of the users in the secondary circuit if they have different operating conditions (same temperature difference). A control is required by third-party equipment to ensure compliance with the unit flow limits.
FLOWZER VPS with TD-based control	Ideal for systems featuring similar users or users with similar operating conditions. Ideal for systems featuring a primary and a secondary circuits physically divided from the heat exchanger or a tank with multiple connections.	<ul style="list-style-type: none"> - Plug&Play: provides for easy and flexible implementation as it is not supplied with options to be fitted and for quick commissioning. 	Risk of over- or underflow for some of the users in the secondary circuit if their temperature difference is not the same due to the existing operating conditions

FLOWZER VPS

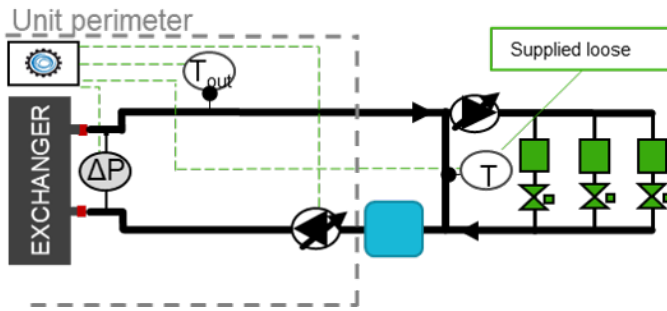

FLOWZER VDT

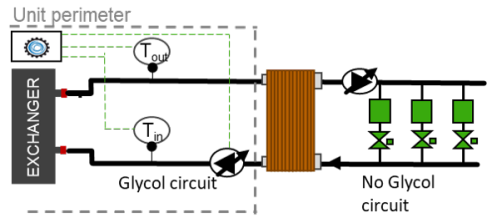
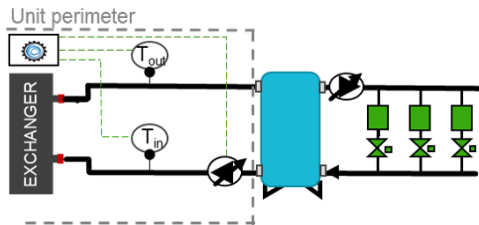

FLOWZER VPS with DT-based control

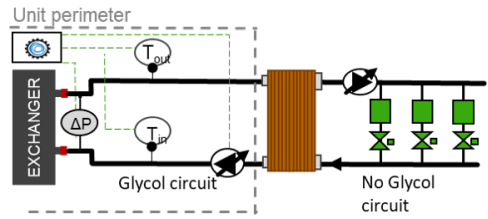
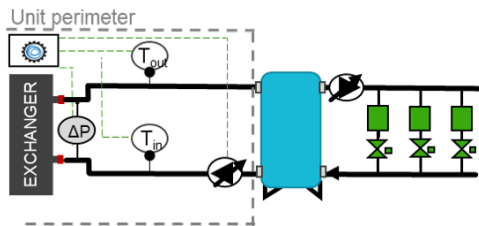

Variable flow system featuring primary circuit only

	Application	Advantages	Disadvantages
Flowzer VFPP	Ideal for new systems intended to reduce installation costs	- Energy saving: the energy consumption during pumping operations can be cut down to 50% if compared with a traditional system Lower CAPEX thanks to reduced installation costs and smaller number of components (one pump less)	Requires some testing to correctly set the pressure available in the system and to correctly position the two transducers, based on the system layout and devices.
Flowzer VD	Ideal for systems fitted with changing users according to the season. Ideal for industrial processes, such as injection moulding, in order for each terminal to operate with the correct discharge head. It is recommended in structured systems in which the client has third-party systems to control the min. and max. flow rate.	- Plug&Play: provides for easy and flexible implementation as it is not supplied with options to be fitted therefore allows for quick commissioning.	A control is required by third-party equipment to ensure compliance with the unit flow limits.

Flowzer VFPP

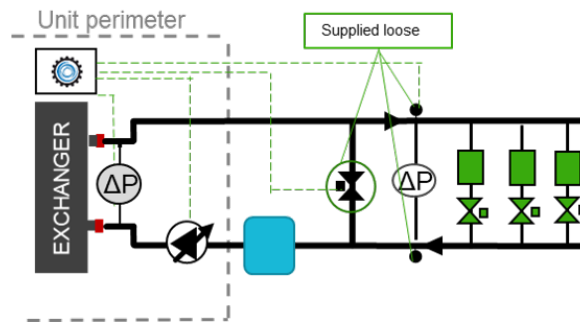

Flowzer VD

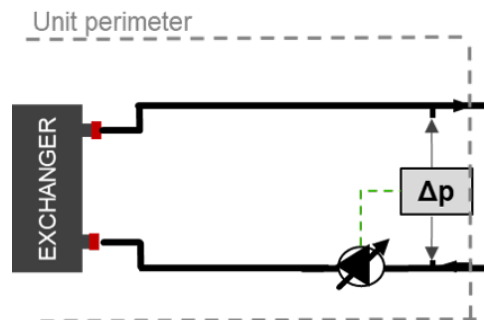

FVPF FLOWZER VP - Inverter for manual pump adjustment cold circuit
FVPC FLOWZER VP - Inverter for manual pump adjustment hot circuit

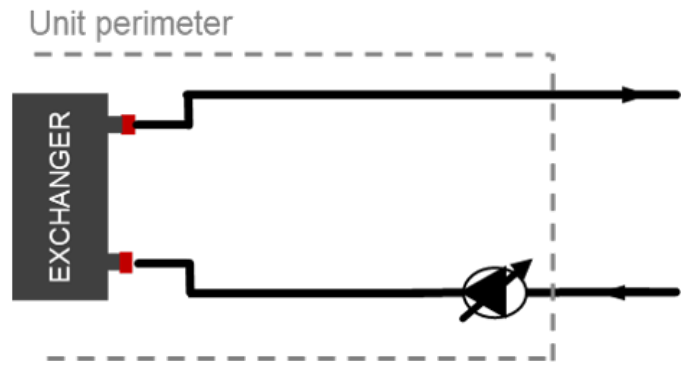

The accessory consists of inserting an inverter in the machine to manually adjust the speed of the pump (or pumps) in order to calibrate the pump flow rate on the head losses of the system. This accessory is to be combined with one of the integrated hydraulic modules that can be selected for the unit. Units equipped with integrated hydraulic module allow a certain level of available discharge head (point A) to be obtained under nominal flow rate conditions Q_d .

But the actual head loss level of the system (e.g. characteristic curve R') normally causes the pump to find a different equilibrium point (point B), with a flow rate Q_r higher than Q_d .

In this condition, in addition to having a different flow from the nominal one (therefore also a different temperature jump), there is also a greater absorption of electric power from the pump itself.

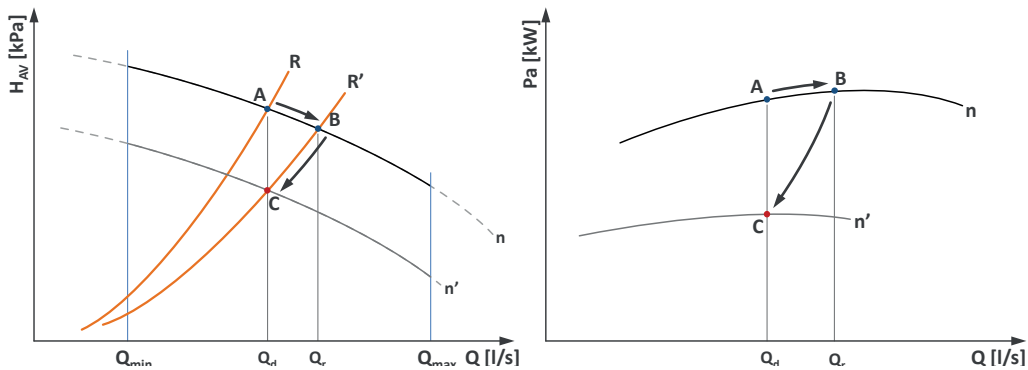

The use of the Flowzer allows the pump speed to be set manually (e.g. at speed n' instead of n) to obtain the design water flow rate and thermal gradient (point C). Once the adjustment procedure has been carried out, the pump will always work at a fixed flow rate.

The adoption of the VP Flowzer allows to considerably reduce the electrical power consumption of the pump with a consequent energy saving. By way of example, a reduction in the flow rate of 10% leads to a reduction in power consumption of around 27%.

For the freecooling units the Flowzer VP is able to manage two different speeds of the pump automatically compensating the pressure drops of the water coil.

FVDF FLOWZER VD - control of available pump discharge head for variable flow systems without monitoring the flow rate limits; cold circuit

FVDC FLOWZER VD - control of available pump discharge head for variable flow systems without monitoring the flow rate limits; hot circuit

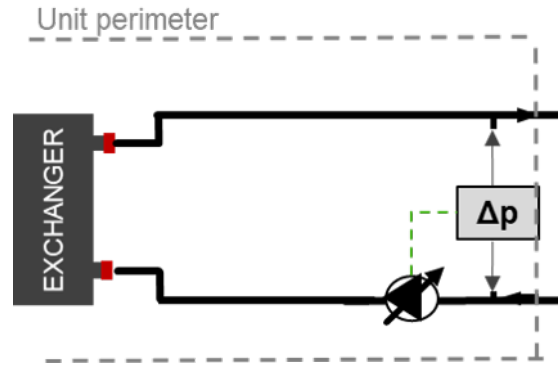

Flowzer VD requires two pressure transducers to be installed in the machine. Through these transducers, the inverter can gauge the actual pressure at the ends of the system and it can automatically adapt the pump speed to obtain a set available discharge head value. Flowzer VD must be combined with Flowzer VP. This accessory therefore allows a constant pressure system to be achieved.

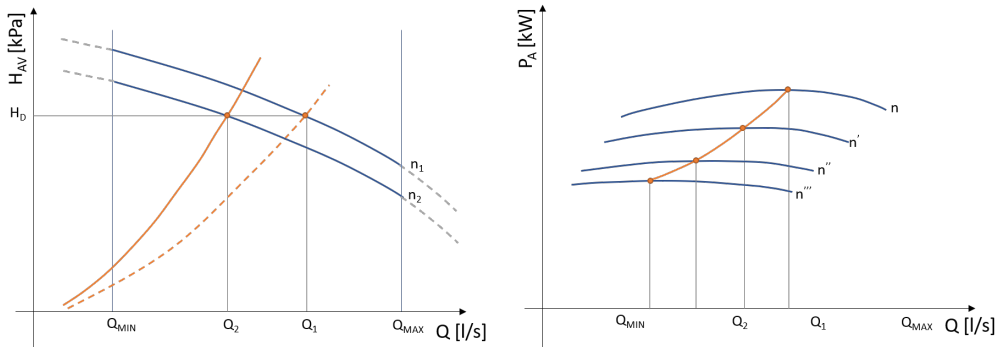

With the Flowzer VD, the customer can set, directly on the display, the available discharge head value (H_d) that the unit must maintain. As can be seen from the graph as the user request decreases, the resistant curve of the plant moves to the left, consequently the inverter reduces the speed of the pump in order to maintain the useful head necessary for the unit. With this system a significant reduction in electrical power is achieved. The customer will have to check that, in minimum flow rate conditions (that is, with the maximum number of user points closed), this is always higher than or equal to the minimum flow rate allowed by the unit.

This accessory is useful when the total head losses of the circuit are slightly variable or when they change depending on the seasons (for example, some user points are active only during summer operation and not during winter operation).

The use of this accessory also allows the pump speed to be adapted to possible fouling of the filter on the hydraulic circuit.

VDEF FLOWZER VDE - flow rate control to keep the flow rate constant as the external working conditions of the system change; cold circuit

VDEC FLOWZER VDE - flow rate control to keep the flow rate constant as the external working conditions of the system change; hot circuit

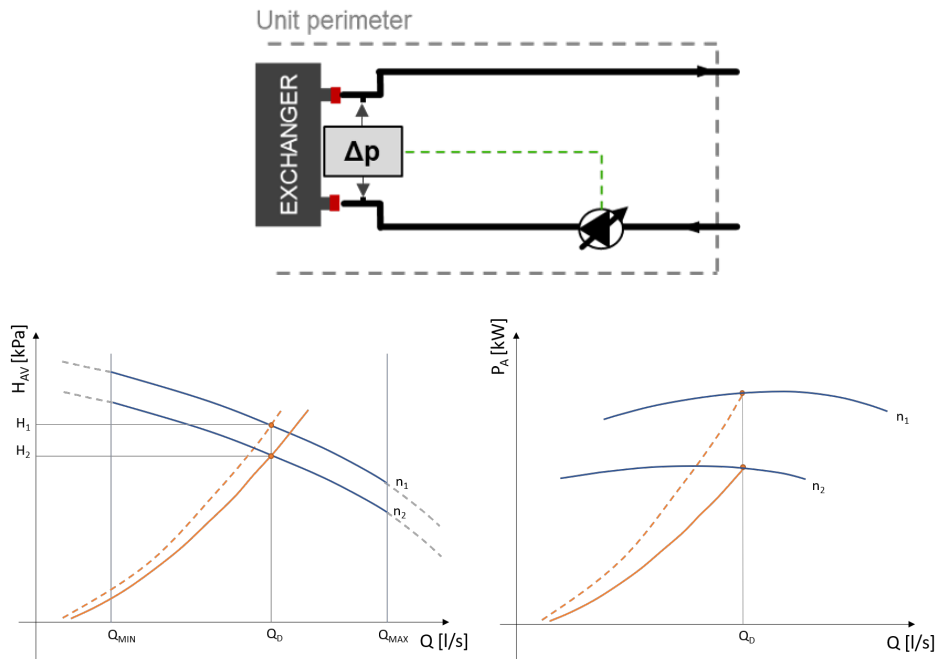

Flowzer VDE is used to automatically adjust the pump speed. As the graph shows, the inverter trips and increases the pump speed if a different condition occurs which would cause an undesired drop in the flow rate (e.g. operation of an external dry cooler). This is a more accurate solution than the VP option alone as it always provides for the water flow (Q_d) required by the design conditions.

Flowzer VDE requires a differential pressure transducer to be installed in the machine. Through this transducer, the inverter can gauge the actual pressure at the ends of the heat exchanger installed in the machine and it can automatically adapt the pump speed for a constant flow value under all conditions. Flowzer VDE must be combined with Flowzer VP.

VDTF FLOWZER VDTF - constant TD-based control in the heat exchanger, with variable flow pump without monitoring the flow rate limits cold circuit

VDTC FLOWZER VDTC - constant TD-based control in the heat exchanger, with variable flow pump without monitoring the flow rate limits hot circuit

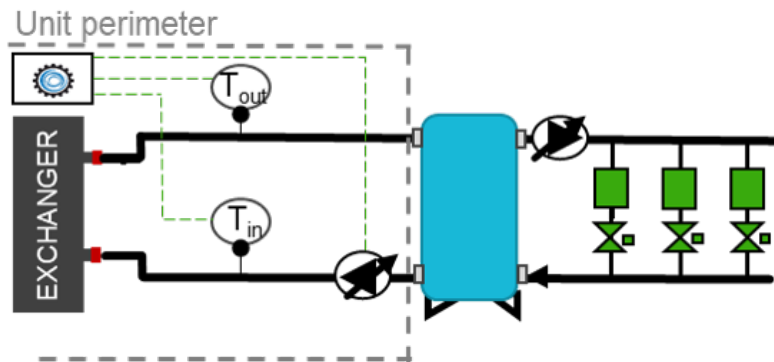

Flowzer VDT uses the temperature sensors installed at the inlet and outlet of the heat exchanger to automatically adjust the pump speed, thus keeping the T delta difference setpoint constant.

The option is not compatible with the Multilogic version. Please refer to the HYZER solutions for the compatibility between variable flow systems and multi-machine systems.

The unit must include the advanced Bluethink controller and just one heat exchanger on the user side.

With the Flowzer VDT, the customer can set, directly on the display, the available delta T value that the unit must maintain. The customer will have to check that, in minimum flow rate conditions (that is, with the maximum number of user points closed), this is always higher than or equal to the minimum flow rate allowed by the unit.

This option is specifically designed for systems in which the system users have similar operating conditions (same temperature difference).

- FVFF FLOWZER VFPP - automatic management of variable flow rate in systems with one single primary circuit and a bypass valve; cold circuit**
- FVFC FLOWZER VFPP - automatic management of variable flow rate in systems with one single primary circuit and a bypass valve; hot circuit**

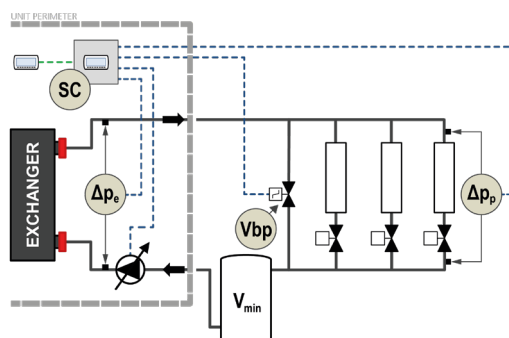

Bluethink solution for a variable flow rate system, consisting solely of a user-side primary circuit.

Flowzer VFPP includes:

- a pressure transducer installed at the ends of the user-side exchanger (Δp_e)
- a dedicated control system, installed at the factory in the electrical control panel of the unit (Sc)
- a modulating bypass valve with servo-motor supplied separately with it (Vbp), supplied loose (installation by the customer)
- two system pressure transducers (Δp_p) supplied separately (installation by the customer)

It is obligatory for the option to be combined with the Flowzer VP (inverter) and with one of the hydraulic modules that can be selected for the unit. The accessory is not compatible with Multilogic. Please contact our sales department for further details.

The unit must include the advanced Bluethink controller, just one heat exchanger on the user side and a minimum capacity step of 25% or less.

The option offers a complete default package to guarantee simple selection, purchasing and commissioning.

Flowzer VFPP has the advantage of:

- implementing an innovative design, which is alternative to the classic system based on fixed flow-rate primary circuit plus secondary circuit
- being ideal for new or entirely redesigned systems, especially for comfort applications
- having a variable flow system, with maximum energy saving
- simplifying the layout of the user circuit
- limiting the capex of the system
- performing a reliable check

The Flowzer VFPP system controller uses an advanced algorithm that enables prevention of unnecessary waste of energy and hunting by the inverter and the bypass valve.

The capex of the system is also reduced thanks to:

- single inverter + pumping module, integrated in the unit
- small internal footprint, due to the simplified layout

The operating principle can be summarized as follows:

- Flowzer VFPP carries out constant control of the discharge head
- the controller modulates the pump speed according to the signal detected by the system transducers Δp_p
- as the demand from the system goes down, the pump speed will be reduced.
- the pump speed can be reduced until it reaches the minimum allowed flow rate on the heat exchanger of the unit
- this flow rate is indirectly monitored through the losses detected by the differential pressure transducer Δp_e
- When the minimum allowed flow rate threshold is exceeded, the control system will open the bypass valve Vbp to recirculate the flow rate that is not required by the system, but is necessary to guarantee the minimum flow rate to the heat exchanger.

In the required minimum load condition (that is, with all system terminals switched off) the necessary minimum volume (V_{min}) must be ensured by the relevant tank to be installed between the unit and the separator or the bypass pipe.

The bypass valve V_{bp} is controlled through a 0-10 V signal and must therefore be installed within 30 m of the unit.

The pressure transducers of the system Δp_p provide a 4-20 mA signal and require two 1/4" female fittings. These transducers must be installed within 200 m of the unit, near the system terminal that is affected by the highest line head losses or in any case in a position where it is possible to measure an adequate pressure value.

Further details can be found in the relevant manual.

VPSF FLOWZER VPS - automatic management of variable flow rate, including balancing of flow rates between primary and secondary circuits; cold circuit

VPSC FLOWZER VPS - automatic management of variable flow rate, including balancing of flow rates between primary and secondary circuits; hot circuit

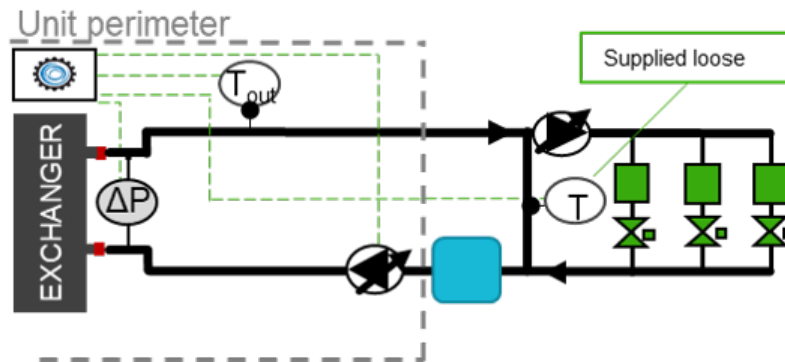

Bluethink solution for a variable flow rate system, consisting of a primary circuit plus secondary circuit.

It is obligatory for the option to be combined with the Flowzer VP (inverter) and with one of the hydraulic modules that can be selected for the unit. The accessory is not compatible with Multilogic. Please contact our sales department for further details.

The unit must include the advanced BlueThink controller and just one heat exchanger on the user side.

The option offers a complete default package to guarantee simple selection, purchasing and commissioning.

Flowzer VPS has the advantage of:

- being ideal for renovations of existing systems, especially for comfort applications
- achieving a complete variable flow system, with maximum energy saving
- implementing a flexible design, e.g. for scalable or multi-zone systems

The maximum energy saving is achieved thanks to the advanced algorithm, which prevents hunting by the inverter and balances the pump speed and the recirculation flow rate to a minimum.

With refurbishments, the system's capex is limited to the unit and its commissioning.

The dimensions of the inverter of the unit and of the pump module can be favoured by the low design discharge head of the primary circuit.

The operating principle can be summarized as follows:

- Flowzer VPS performs a smart check of the flow rate in the primary circuit and balances it with the flow rate in the secondary circuit.
- the system controller modulates the pump speed according to the condition detected by the system sensors T
- if the system terminals are switched off, the flow rate of the secondary circuit will decrease; therefore the direction of flow is detected indirectly as temperature difference by the system sensors through the separator or the bypass pipe
- The check thus contributes to reducing the speed of the primary pump until the min. flow threshold in the heat exchanger of the unit is exceeded.

• this flow rate is indirectly monitored through the losses detected by the differential pressure transducer Δp_e
In the required minimum load condition (that is, with all system terminals switched off) the necessary minimum volume (V_{min}) must be ensured by the relevant tank to be installed between the unit and the separator or the bypass pipe.

The temperature sensors of the system T provide a 4-20 mA signal and require 1/2" female fittings.

Further details can be found in the relevant manual.

VPDF flowzer vps with TD-based control - automatic management of variable flow rate, including control with constant TD (difference between input and output temperature in the heat exchanger on the user side) in systems featuring both the primary and secondary circuits. cold circuit

VPDC flowzer vps with TD-based control - automatic management of variable flow rate, including control with constant TD (difference between input and output temperature in the heat exchanger on the user side) in systems featuring both the primary and secondary circuits. hot circuit

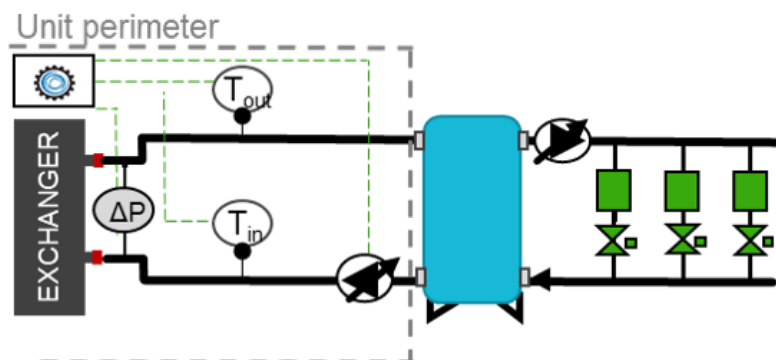

Bluethink solution for variable flow systems - ideal for systems featuring a primary and a secondary circuit physically divided by a heat exchanger or a tank with multiple connections.

flowzer vps with TD-based control includes:

- a differential pressure transducer, installed at the factory at the ends of the user-side heat exchanger of the unit (Δp_e)

The option must be necessarily combined with the Flowzer VP (inverter) and with one of the hydraulic modules that can be selected for the unit. The option is not compatible with the Multilogic version. Please refer to the HYZER solutions for the compatibility between variable flow systems and multi-machine systems.

The unit must include the advanced Bluethink controller and just one heat exchanger on the user side.

The option offers a complete default package to guarantee simple selection, purchasing and commissioning.

flowzer vps with TD-based control offers the following advantages:

- a full package that is easy to install as all the regulating devices are pre-assembled and pre-wired in the unit;
- achieving a complete variable flow system, with maximum energy saving
- the ideal solution to refurbish existing systems where the T different must be kept constant in the system, especially in comfort applications;

The maximum energy saving is achieved thanks to the advanced algorithm, which prevents hunting by the inverter and balances the pump speed and the recirculation flow rate to a minimum.

The dimensions of the inverter of the unit and of the pump module can be favoured by the low design discharge head of the primary circuit.

The operating principle can be summarized as follows:

- flowzer vps with TD-based control performs smart monitoring of the flow rate in the primary circuit, keeping the T difference constant in the heat exchanger;
- the system controller modulates the pump speed according to the condition detected by the temperature sensors (T) in the system, which are installed at the inlet and outlet of the heat exchanger on the user side;
- the difference in the water temperature (T) and flow rate are inversely proportional, which is why if the T difference is reduced at the same performance level, the water flow exceeds the flow required by the system and the pump speed is reduced in order to save energy;

on the other hand, when the load increases, the T difference increases in the system and the pump speed is increased accordingly.

- The check contributes to reducing/increasing the speed of the pump in the primary circuit until the min./max. flow threshold admitted in the heat exchanger of the unit is exceeded.
- this flow rate is indirectly monitored through the losses detected by the differential pressure transducer Δp_e

The temperature sensors of the system output a 4-20 mA signal.

Further details can be found in the relevant manual.

HFxF HYZER E VFPP function cold circuit

HFxC HYZER E VFPP function hot circuit

The HYZER E VFPP function combines the Multilogic function, which is designed to manage multi-machine systems, with the FLOWZER VFPP control for variable flow systems.

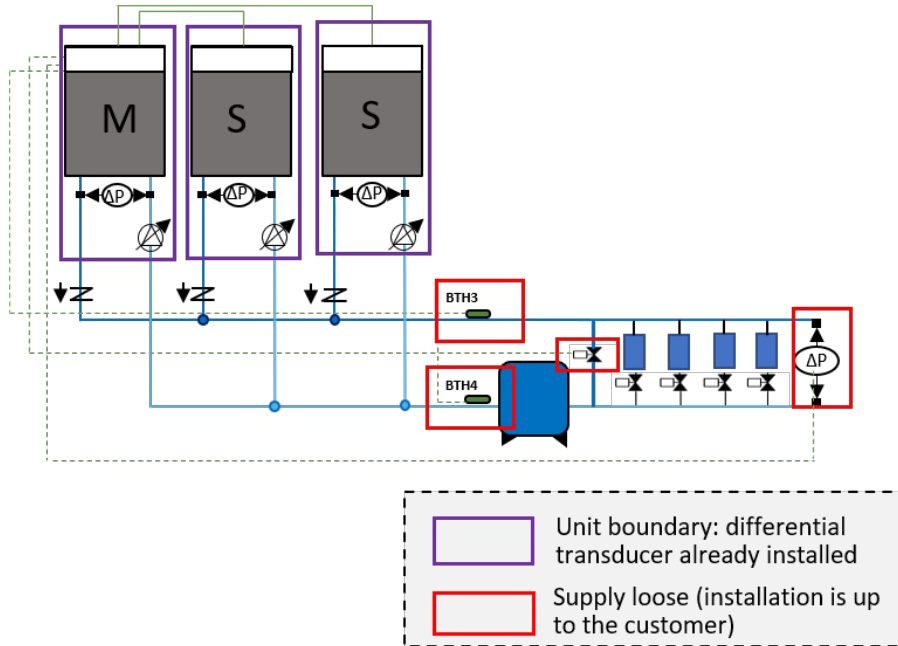

It is obligatory for the option to be combined with the Flowzer VP (inverter) and with one of the hydraulic modules that can be selected for the unit.

The unit must include the advanced Bluethink controller, just one heat exchanger on the user side and a minimum capacity step of 25% or less.

Units operate according to the Master/Slave logic that is typical of a Multilogic system. For additional details, please refer to the FMx option.

The HYZER E function requested with the unit can be:

- **HF0:** HYZER E VFPP function for Slave units;
- **HF2:** HYZER E VFPP function for the Master unit in order to manage up to 2 Slave units;
- **HF6:** HYZER E VFPP function for the Master unit in order to manage up to 6 Slave units.

If you need to connect more than 6 slaves (up to 31), you can ask for a quotation from our sales department.

For the slave units, the accessory requires:

- programming of the unit as slave of a system of machines in Multilogic network

For the master units, the accessory requires:

- programming of the unit as master of a system of machines in Multilogic network
- entering of the parameters necessary for connection with the individual slave units
- installation in the electrical control panel of a network switch to allow the units to be connected in a LAN network.
- the supply of 2 temperature probes to be positioned on the delivery and return manifold for system thermoregulation (supplied with the system - installation and wiring by the customer);
- the supply of two pressure transducers (supplied with the system - installation and wiring by the customer) to be installed near the system terminal that is affected by the highest head losses in the line or in any case in a position where it is possible to measure an adequate pressure value.
- The option also includes the supply of a bypass valve controlled by a 0-10 V signal, which must be selected in function of the system capacity. Please refer to the VBx options for correct selection.

The connection between the master unit and the slave units made with a CAT cable. 5E/UTP (prepared by the customer) with RJ45 connectors. Maximum cable length 100m.

For further details, please refer to the controller manual.

VBxF VFPP bypass valve for HYZER E cold circuit

VBxC VFPP bypass valve for HYZER E hot circuit

The option is supplied with the bypass valve, which is selected according to the system capacity.

This option must be selected with either the "HYZER E VFPP function for Master unit to manage up to 2 Slave units" or "HYZER E VFPP function for Master unit to manage up to 6 Slave units".

	System capacity range**	Quantity	Diameter	Qmax**
	kW	-	in	m ³ /h
S_A	<240	1	2 1/2"	41.3
S_B	240÷335	1	3"	57.6
S_C	335÷570	1	4"	98
S_D	570÷850	1	5"	146.2
S_E	850÷1250	1	6"	215
S_F	1250÷1700	2	2 x 5"	2 x 146.2
S_G	1700÷2500	2	2 x 6"	2 x 215

** values based on a 5 °C temperature difference between the delivery and the return temperature

HSxF HYZER E VPS function cold circuit

HSxC HYZER E VPS function hot circuit

The HYZER E VPS function combines the Multilogic function, which is used to manage multi-machine systems, with the FLOWZER VPS control for variable flow systems.

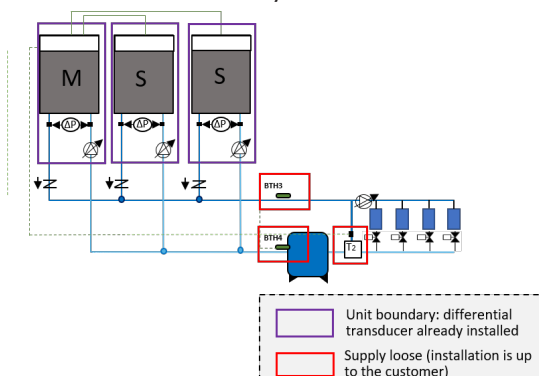

It is obligatory for the option to be combined with the Flowzer VP (inverter) and with one of the hydraulic modules that can be selected for the unit.

The unit must include the advanced Bluethink controller, just one heat exchanger on the user side and a minimum capacity step of 25% or less.

Units operate according to the Master/Slave logic that is typical of a Multilogic system. For additional details, please refer to the FMx option.

VPS control requires the installation on the machine of a differential transducer at the ends of the user-side heat exchanger in order to keep the flow rate in the system within a specific min. value allowed.

For additional details on the FLOWZER VPS logic, please refer to the dedicated FVPS option.

The networked units may be of different types, and the same observations as for the Multilogic option apply:

- if there are both chiller units and heat pumps in the network, the Master unit must obligatorily be one of the HP units;
- if there are both free-cooling and non free-cooling units in the network, the Master unit must obligatorily be one of the free-cooling units.

The HYZER E function requested with the unit can be:

- **HS0:** HYZER E VPS function for Slave units;
- **HS2:** HYZER E VPS function for the Master unit in order to manage up to 2 Slave units;
- **HS6:** HYZER E VPS function for the Master unit in order to manage up to 6 Slave units.

If you need to connect more than 6 slaves (up to 31), you can ask for a quotation from our sales department.

For the slave units, the accessory requires:

- programming of the unit as slave of a system of machines in Multilogic network

For the master units, the accessory requires:

- programming of the unit as master of a system of machines in Multilogic network
- entering of the parameters necessary for connection with the individual slave units
- installation in the electrical control panel of a network switch to allow the units to be connected in a LAN network.
- the supply of 2 temperature probes to be installed on the delivery manifold and on the bypass branch, which are typical of VPS control (supplied with the system - installation and wiring by the customer).

The connection between the master unit and the slave units made with a CAT cable. 5E/UTP (prepared by the customer) with RJ45 connectors. Maximum cable length 100m.

For further details, please refer to the controller manual.

HDxF HYZER E VPS with DT-based control function cold circuit

HDxC HYZER E VPS with DT-based control function hot circuit

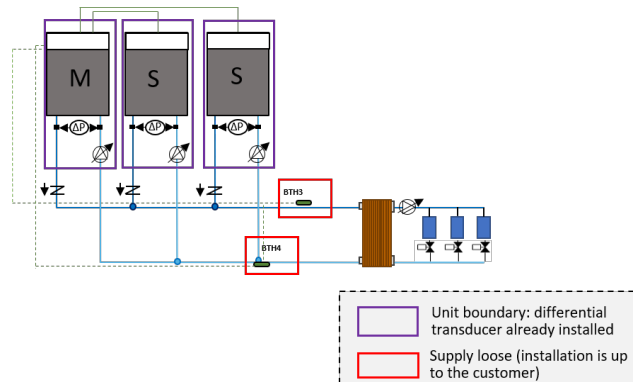

The HYZER E VPS with TD-based control function combines the Multilogic function, which is used to manage multi-machine systems, with the FLOWZER VPS with DT-based control control for variable flow systems.

It is obligatory for the option to be combined with the Flowzer VP (inverter) and with one of the hydraulic modules that can be selected for the unit.

The unit must include the advanced Bluethink controller, just one heat exchanger on the user side and a minimum capacity step of 25% or less.

Units operate according to the Master/Slave logic that is typical of a Multilogic system. For additional details, please refer to the FMx option.

VPS with DT-based control control requires the installation on the machine of a differential transducer at the ends of the user-side heat exchanger in order to keep the flow rate in the system within a specific min. value allowed.

For additional details on the FLOWZER VPS with TD-based control logic, please refer to the dedicated FVPS with DT-based control option.

The networked units may be of different types, and the same observations as for the Multilogic option apply:

- if there are both chiller units and heat pumps in the network, the Master unit must obligatorily be one of the HP units;
- if there are both free-cooling and non free-cooling units in the network, the Master unit must obligatorily be one of the free-cooling units.

The HYZER E function requested with the unit can be:

- **HD0:** HYZER E VPS with TD-based control function for Slave units;
- **HD2:** HYZER E VPS with TD-based control function for the Master unit in order to manage up to 2 Slave units;
- **HD6:** HYZER E VPS with TD-based control function for the Master unit in order to manage up to 6 Slave units.

If you need to connect more than 6 slaves (up to 31), you can ask for a quotation from our sales department.

For the slave units, the accessory requires:

- programming of the unit as slave of a system of machines in Multilogic network

For the master units, the accessory requires:

- programming of the unit as master of a system of machines in Multilogic network
- entering of the parameters necessary for connection with the individual slave units
- installation in the electrical control panel of a network switch to allow the units to be connected in a LAN network.

The connection between the master unit and the slave units made with a CAT cable. 5E/UTP (prepared by the customer) with RJ45 connectors. Maximum cable length 100m.

For further details, please refer to the controller manual.

PVX Variable flow setup for HYZER X

The dedicated HYZER X controller is designed to manage the different units, devices and components that make up a hydronic system.

Systems featuring this controller require that the PVX option be installed at the ends of the user-side heat exchanger of a differential pressure transducer so that the machine is set up for variable flow rate control.

This option is mandatory in all units making up the system.

For additional information on the product HYZER X, please refer to the specific technical catalogue.

VIX Shut-off valves for systems with external pumps for HYZER X

Systems featuring the HYZER X controller enable the selection of the shut-off valve used in systems that have an external pumping unit.

The option is always supplied separately from the unit and is for installation by the customer.

FLMX User-side flow meter for HYZER X

Systems featuring the HYZER X controller enable the selection of the flow meter option to calculate the flow rate and the performances of the units.

The option is supplied with the system for installation on the user side (installation by customer).

Electrical accessories

Some accessories may be incompatible with each other even if not expressly indicated.

CSP Set point compensation depending on external air temperature

For units fitted with this accessory, the set point of the unit is set so that it can vary between two values, a maximum and a minimum, depending on the external air temperature. The compensation ramp and the maximum and minimum values of the set point can be changed by the user.

Unless otherwise specified in the order, the controller will be set to implement a positive compensation logic according to the temperatures shown in the following diagrams:

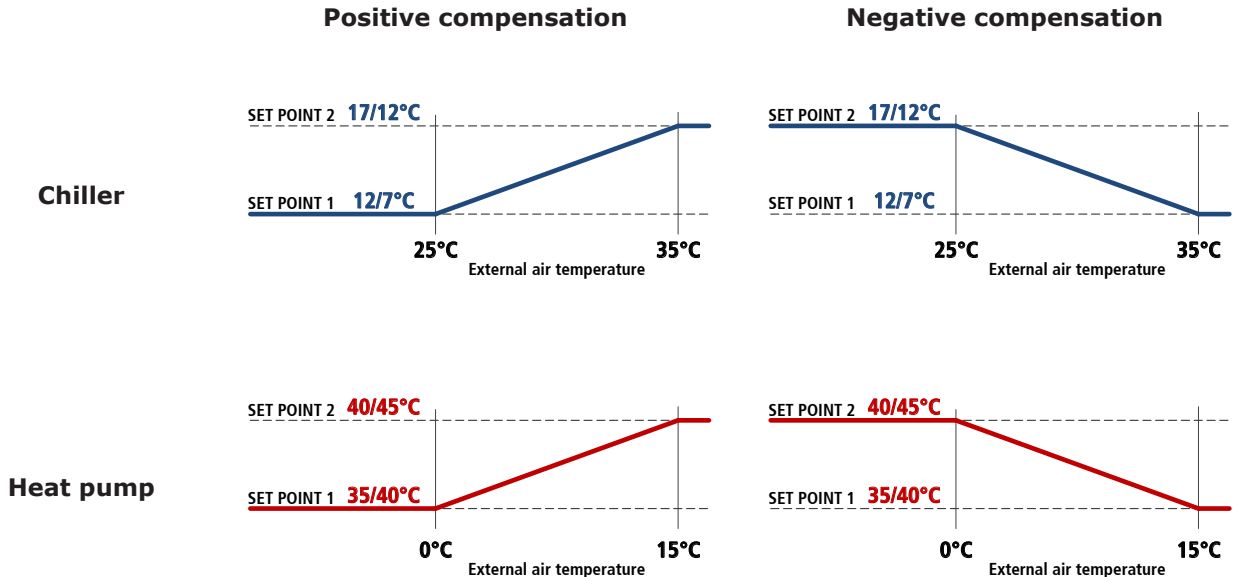

CSTI Enabling for additional heat source

Through a potential free contact, the controller gives the OK signal to an additional heat source to intervene in support of the unit to meet the heat load.

The OK signal to the additional source is given only if the outside air temperature is lower than a settable threshold and if the water temperature set point is not reached within a set time.

CSTS OK signal for substitute heat source

Through a potential free contact, the controller gives the OK signal to an alternative heat source so that it will meet the total heat load demand when the external air temperature is lower than a settable threshold.

For external air temperatures below this threshold, hot water production through the use of the compressors is disabled.

NSS Night Shift System

This accessory is applied to high efficiency /LN version units with speed adjuster or to SLN units.

In the day time slot, which is normally the one with the highest heat load, priority is given to efficiency and therefore the machine works with a fan control curve that maximises the EER. In this time slot, therefore, the unit is a high efficiency low noise machine (equivalent to HE/LN)

In the night time band (or in any case from time band decided by the customer), the priority changes to limiting the noisiness of the machine and therefore the controller carries out an adjustment of the control ramp of the condensing fans, thereby reducing the air flow rate and consequently the noise emission level. So, in this time band, the unit is a super low noise machine (equivalent to SLN).

In any case, if there is a need for additional cooling capacity, the controller will manage the demand, if necessary, by accelerating the fans and keeping condensation within the correct operating limits.

The time slots can be set from the control depending on installation requirements.

When the unit is working in heat pump mode, in order to maximise the COP and to obtain the widest possible operating limits, the control of the unit forces the fans to the maximum speed also during the night time bands.

LIID Limitation of the current absorbed by digital input

When this accessory is requested, a digital input is prepared in the terminal board to activate the forced capacity reduction of the unit to a set fixed level.

This accessory is useful when there is a need to necessarily limit the power absorbed by the unit as regards particular conditions.

We point out that, in some conditions (for example, during defrosting, oil return cycles or hourly compressor rotation procedures), the controller could force the unit to operate at full capacity for limited periods of time.

RE1P Relay for management of 1 external pump**R1PC Relay for management of 1 external pump hot circuit**

This accessory can be requested for units without pumps and allows a pump outside the machine to be controlled.

R2PF Relay for management of 2 external pumps, cold circuit**R2PC Relay for management of 2 external pumps, hot circuit**

This accessory can be requested for units without pumps and allows two pumps outside the machine to be controlled with a running/stand-by logic by implementing a rotation on the hours of operation.

The two pumps are controlled by two separate relays.

RIF Power factor correction to $\cos\phi \geq 0.95$

With this accessory, an electrical control panel (IP54 protection rating), containing power factor correction capacitors to make the $\cos\phi$ of the unit greater than or equal to 0.95, is supplied with the unit. The capacitors should be connected (by the customer) to the electrical control panel of the unit in the specially prepared terminal board.

Besides reducing the absorbed reactive power, the use of this accessory also allows the maximum absorbed current to be lowered.

RMMT Maximum and minimum voltage relay

This accessory constantly monitors the voltage value and the unit's power supply phase sequence. If the supply voltage does not fall within the set parameters or there is a phase reversal, an alarm is generated that stops the machine to prevent damage to its main parts

SEDC Double set point from digital input hot circuit

The accessory allows you to preset two different operating set points and manage the change from one to the other through a digital signal.

The set point temperatures must be specified when ordering. For optimization of the unit, reference will be made to the highest set point.

Unless otherwise specified in the order, the controller will be set at the factory with the following temperatures:

- set point 1 at 45°C
- set point 2 at 40°C

SEDF Double set point from digital input cold circuit

The accessory allows you to preset two different operating set points and manage the change from one to the other through a digital signal.

The set point temperatures must be specified when ordering. For optimization of the unit, reference will be made to the lowest set point.

Unless otherwise specified in the order, the controller will be set at the factory with the following temperatures:

- set point 1 at 7°C
- set point 2 at 12°C

SEVC Variable set point with remote signal hot circuit

The accessory allows the set point to be varied continuously between two preset values, a maximum and a minimum, depending on an external signal that can be of the 0-1V, 0-10V or 4-20mA type.

The set point temperatures and the type of signal to use for the adjustment must be specified when ordering. For optimization of the unit, reference will be made to the highest set point.

Unless otherwise specified in the order, the controller will be set at the factory with 0-10V analogue input and with the following temperatures:

- 0V will correspond to a set point of 45°C
- 10V will correspond to a set point of 40°C

SEVF Variable set point with remote signal cold circuit

The accessory allows the set point to be varied continuously between two preset values, a maximum and a minimum, depending on an external signal that can be of the 0-1V, 0-10V or 4-20mA type.

The set point temperatures and the type of signal to use for the adjustment must be specified when ordering. For optimization of the unit, reference will be made to the lowest set point.

Unless otherwise specified in the order, the controller will be set at the factory with 0-10V analogue input and with the following temperatures:

- 0V will correspond to a set point of 7°C
- 10V will correspond to a set point of 12°C

SOFT Electronic soft-starter

The scroll compressors have DOL (Direct On Line) starting and therefore the maximum inrush current I_{MIC} will be 4/5 times its nominal current I_{nom} .

If the unit is equipped with the electronic soft-starter accessory, the starting of each compressor is done with an acceleration ramp that allows the effective value (rms value) of the inrush current of the individual compressor to be lowered.

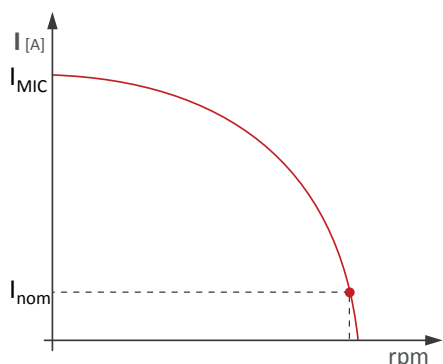

Current trend without accessory Electronic soft-starter

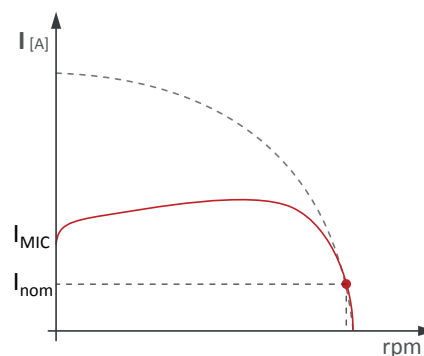

Current trend with accessory Electronic soft-starter

If the unit is equipped with accessory "Power factor correction to $\cos\phi \geq 0.95$ ", this last will be electro-mechanically connected only at the end of the acceleration ramp of the soft-starter.

TERM Remote-controlled user terminal panel

This accessory allows the terminal normally situated on the machine to be replicated on a support situated at a distance. It is particularly suitable when the unit is placed in an area that is not easily accessible.

The accessory is supplied loose and is to be installed by the customer at a maximum distance of 120m from the unit. We advise using a cable of the following type: "TECO O.R. FE 2x2xAWG24 SN/ST/PUR".

For this accessory, there is a dedicated serial port.

IACV Automatic circuit breakers

With this accessory, automatic circuit breakers are installed instead of fuses for the protection of auxiliary loads. Also, the same accessory uses automatic circuit breakers with adjustable thermal overload protection to protect the compressors.

COTW Outgoing water temperature control

With this accessory, outgoing instead of incoming water temperature control is used.

RAV Anti-freeze heater for condensate drip tray

A heating cable, glued to the bottom, can be combined with the condensate drip tray to prevent ice formation at the base of the coil or near the drains.

The heater is controlled by a thermostat and is activated depending on the external air temperature.

Recommended accessory for installations in cold regions.

RAM Antifreeze oversized heater for condensate drip tray

RAM accessory provide an oversized electrical heaters system.

Heaters are managed with a thermostat , activated depending on outside air temperature.

Recommended accessory for installation in regions with harsh climate and very low temperatures where defrosting cycles could occurs frequently or in case of installations particularly exposed to cold winds.

If the unit is equipped with the electronic soft-starter accessory, the starting of each compressor is done with an acceleration ramp that allows the effective value (rms value) of the inrush current of the individual compressor to be lowered.

Network accessories

BEET Blueeye® via Ethernet

Blueeye® is a supervision platform that enables remote monitoring of one or more units in the same system interconnected through a network with Modbus protocol.

This accessory features the Blueeye device, as already installed and wired in the unit.

The critical variables to be monitored over time are identified for each connected device. These variables are sampled and saved to the cloud so that they are accessible at all times through a web portal or a mobile APP (available for Android and iOS).

The following options can be selected for connection to the internet:

- a LAN (Ethernet) connection - available in the system;
- a connection to a mobile network - at least 3G. The data SIM card is not included.

Three different types of contracts can be signed.

Blueeye® Cloud Basic:

- to monitor a max. of 20 variables in total over max. 5 units/peripherals;
- to set a min. sampling frequency of 60 seconds.

Blueeye® Cloud Advanced:

- to monitor a max. of 200 variables in total over max. 10 units/peripherals;
- to set a min. sampling frequency of 5 seconds.

Blueeye® Connect:

- To monitor up to 10 units/peripherals.

Subscribing to any of the **Blueeye® Cloud** enables:

- viewing the history of the monitored variables, in the form of both numerical values and graphs;
- downloading the history of variables in CSV format;
- the creation of automatic reports;
- setting notifications (via APP or mail) with settable thresholds for each variable;
- switching the unit ON/OFF remotely;;
- changing the set point remotely;
- selection of SUMMER/WINTER mode remotely (for reversible units only).

The subscription to the **Blueeye® Connect** service offers the advantages below:

- a safe connection (tunnelling) between the user and the remote unit through the Blueeye® portal;
- full access to the remote controller;
- real time monitoring;
- software upgrading.

Blueeye® via Ethernet is only available for units supplied with an advanced controller and does not include any type of service. This service must be purchased separately based on the number of units/devices to be connected and the number of variables to be monitored. In order to connect multiple units to **Blueeye® device, the network switch is required (this accessory is sold separately).**

Units can also be connected to the Blueeye device through the RS485 network featuring a Modbus RTU protocol (for this option, refer to BERS accessory).

For further details, refer to the specific Blueeye® documentation.

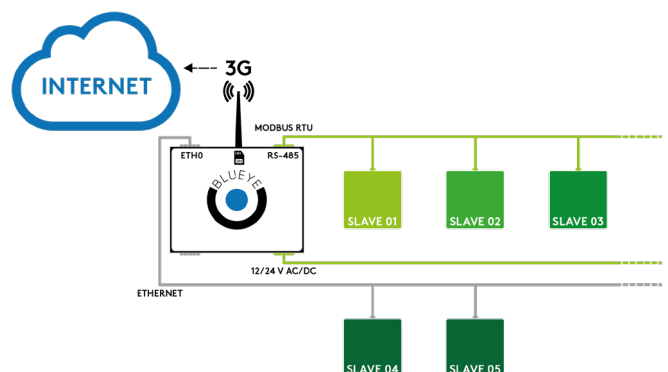
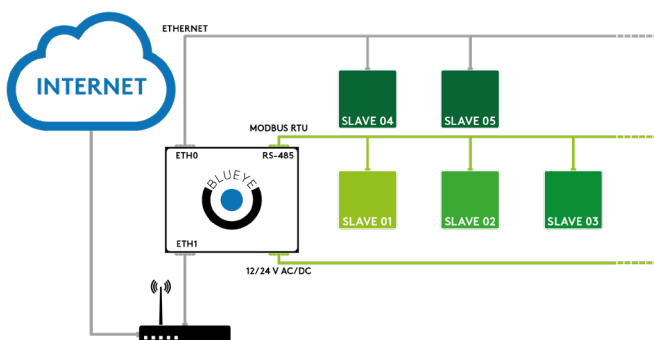

FMx Multilogic Function

The Multilogic function allows management of up to 32 units equipped with advanced Bluethink controller and connected in hydraulic parallel with each other.

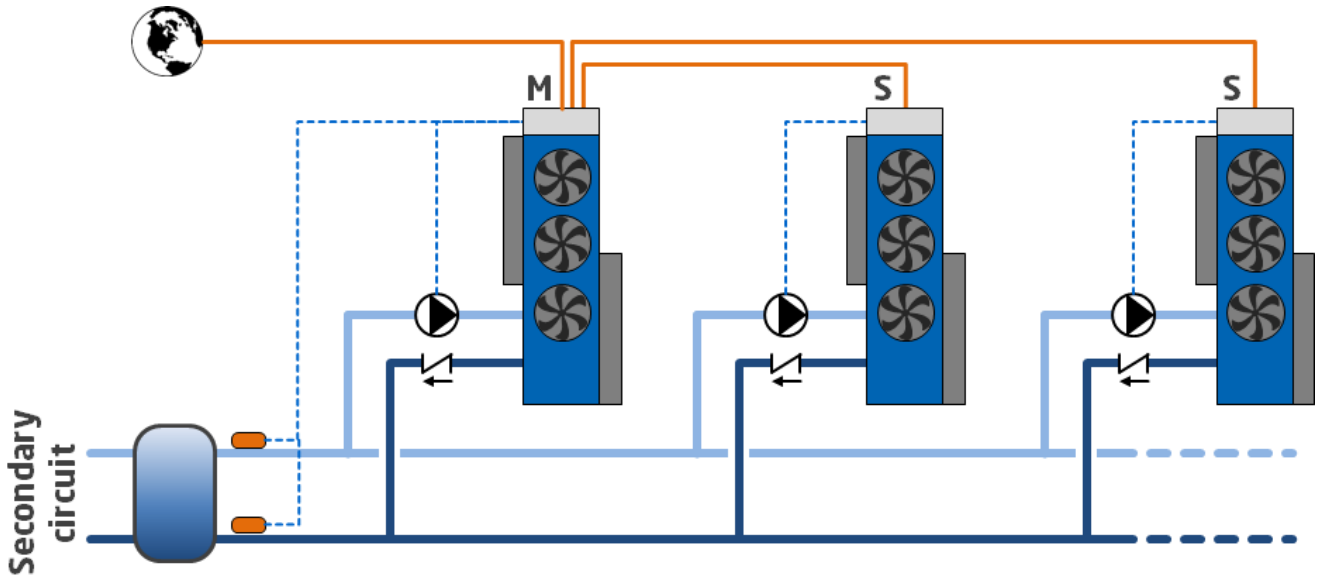

On the basis of the information recorded by the temperature probes installed on the delivery and return manifolds of the system, with the master unit, a capacity request is generated that is distributed among the units connected in the Multilogic network according to settable priority and optimization logics.

If communication between the units fails or if the master is off-line, the slave units can continue to work according to the set thermoregulation parameters.

The connected units can be different from each other, in terms of capacity and set-up, provided the following rule is complied with: if there are both free cooling and non free-cooling units in the Multilogic network, the Master unit must obligatorily be one of the free-cooling units.

The Multilogic function that can be requested with the unit can be:

- **FM0:** Multilogic function for Slave unit
- **FM2:** Multilogic function for Master unit for managing up to 2 Slaves
- **FM6:** Multilogic function for Master unit for managing up to 6 Slaves

If you need to connect more than 6 slaves (up to 31), you can ask for a quotation from our sales department.

For the slave units, the accessory requires:

- programming of the unit as slave of a system of machines in Multilogic network

For the master units, the accessory requires:

- programming of the unit as master of a system of machines in Multilogic network
- entering of the parameters necessary for connection with the individual slave units
- installation in the electrical control panel of a network switch to allow the units to be connected in a LAN network.
- the supply of 2 temperature probes to be positioned on the delivery and return manifold of the system (supplied separately with it, installation and wiring by the customer)

The connection between the master unit and the slave units made with a CAT cable. 5E/UTP (prepared by the customer) with RJ45 connectors. Maximum cable length 100m.

PBA BACnet protocol over IP (Ethernet)

The controller is set for use, in read and write mode, of the BACnet port on IP protocol.

By default, the programming gives read-only access to the control of the unit. Reading / writing access is available on field with a service level.

SW4P Network switch with 4 ports

The accessory includes installation in DIN rail of a professional 4-port network switch. Requires Blueeye via Ethernet.

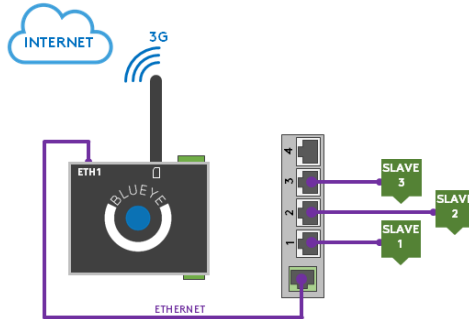

SW8P Network switch with 8 ports

The accessory includes installation in DIN rail of a professional 8-port network switch. Requires Blueeye via Ethernet.

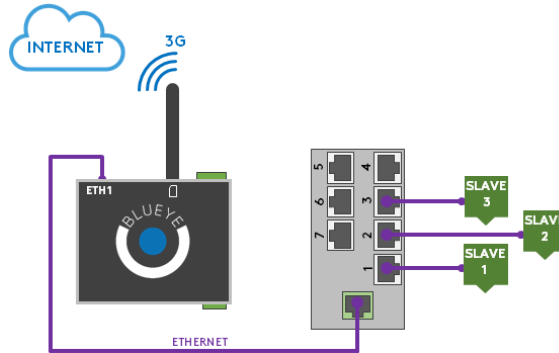

SMAP Setup of Smartlink+ functions

This option is used to connect the controller in the unit with the controller of a Swegon GOLD™ air handling unit via the Ethernet port TCP/IP, so allowing the operating logics of hydronic and ventilation systems to be merged into a single logic for the achievement of maximum energy efficiency and comfort. This option is only available for units featuring an advanced controller and it is compatible with Multilogic and Hyzer systems only if the machine is the Master.

The option is incompatible with:

- double set point
- variable set point with remote signal
- set point compensation depending on external air temperature
- all communication protocols.

Other accessories

AG Rubber anti-vibration mounts

These allow you to reduce the vibrations transmitted from the unit to the surface it is standing on. Accessory supplied loose.

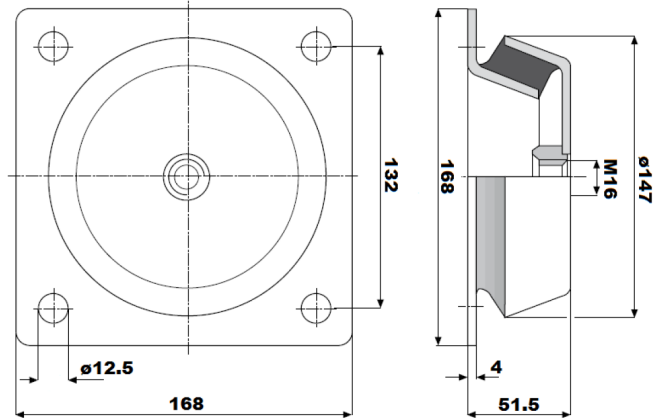

AM Spring anti-vibration mounts

These allow you to reduce the vibrations transmitted from the unit to the surface it is standing on. Accessory supplied loose.

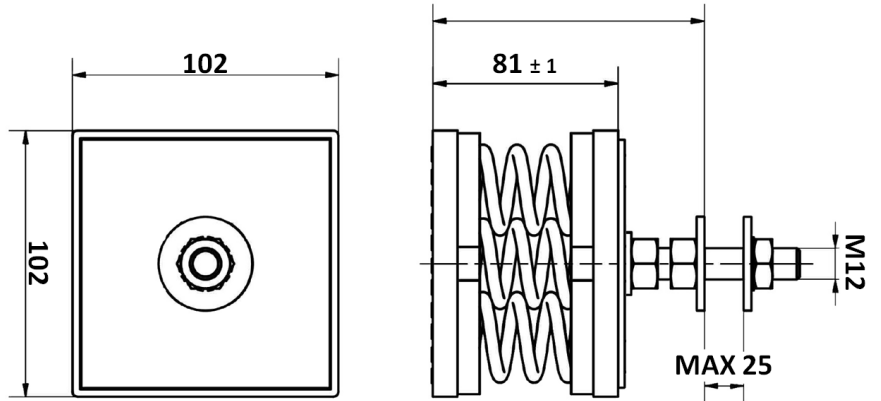

ALPR Pre-painted aluminium coil

This option uses finned pack coils with copper tubes and pre-painted aluminium fins.

ANTC Coil treated with anti-corrosion paints

The treatment is applied exclusively to finned pack coils with copper tubes and aluminium fins and consists of aluminium passivation and coating with a polyurethane base; a double layer of paint, of which the first passivates the aluminium and acts as primer and the second is a polyurethane based surface coating. The product has high resistance to corrosion and all environmental conditions.

The choice of whether or not to treat the exchanger should be made in relation to the environment in which the unit is to be installed and through observation of other structures and machinery with exposed metal surfaces present in the destination environment.

The cross observation criterion is the most valid method of selection currently available without having to carry out preliminary tests or measurements with instruments. The identified reference environments are:

- marine coastal
- industrial
- urban with a high housing density
- rural

KC1 Calibration kit - service tool + adapter + flow meter

The leakage sensor inside the compressor compartment needs to be calibrated during the unit installation phase, and periodically every 6 months. To carry out the calibration it is possible to use the "service tool + adapter + flow meter" kit. A propane cylinder, which is not supplied by Swegon, is also required to perform the calibration. More information on the calibration procedure is available in the installation, use and maintenance manual.

PRAC Steel profiles frames for container shipment

This accessory foresees the mounting of steel profiles frames on the unit for its loading into container. When this accessory is required it's for the shipping of the unit into container and its loading is mandatory to be done at the factory

RAT Anti-intrusion nets

An arc-welded, painted net (RAL colour 7035) is installed to close off the external openings so as to prevent access to the technical compartment by unauthorized personnel.



SLIT Special pallet/skid for container shipment

The unit is placed on a skid that makes the container loading and unloading operations easier. The accessory is mandatory if shipping by container is required

STL Brackets for transport over long distances

The accessory consists of adding reinforcing bars to the structural metalwork. This allows the strength of the structure to be increased for long distance road transport.

KTC Condensate drain pan connection pipes kit

Pipes for draining water collected in the condensate drain tray are supplied assembled and connected. Pipes are supplied connected and fixed for a "plug and play" installation needs RAV or RAM accessory
Electrical heating resistances are installed inside drain pipes to avoid ice formation

TECHNICAL SPECIFICATIONS

OMICRON Zero S4

			5.2	6.2	7.2	8.2
Cooling						
Refrigeration capacity	(1)	kW	50.6	58.5	69.9	83.2
Total absorbed power	(1)	kW	16.3	19.3	23.7	26.7
EER	(1)		3.1	3.03	2.95	3.11
Heating						
Heating capacity	(2)	kW	52.5	61.7	70.8	83.2
Total absorbed power	(2)	kW	15.8	18.4	21.1	24.8
COP	(2)		3.33	3.36	3.36	3.36
Cooling + Heating						
Refrigeration capacity	(3)	kW	48.1	58.3	68.9	79.5
Heating capacity	(3)	kW	62.3	75.4	89.1	102.8
Total absorbed power	(3)	kW	14.3	17.2	20.3	23.5
TER	(3)		7.73	7.78	7.77	7.75
Compressors						
Compressors/Circuits		n°	2/2	2/2	2/2	2/2
Minimum capacity reduction step	(7)	%	50	50	50	50
Refrigerant charge	(6)	kg	5.2	5.2	5.4	7.3
Fans						
Quantity		n°	4	4	4	6
Total air flow rate		m³/h	22400	22400	22400	33600
Cold-side heat exchanger						
Quantity		n°	1	1	1	1
Water flow rate	(1)	m³/h	8.7	10.1	12	14.3
Head loss	(1)	kPa	18	22	19	26
Hot-side heat exchanger						
Quantity		n°	1	1	1	1
Water flow rate	(1)	m³/h	9.1	10.7	12.3	14.4
Head loss	(1)	kPa	11	13	13	14
Noise levels						
Sound power level cooling	(4)	dB(A)	85	85	85	87
Sound pressure level cooling	(5)	dB(A)	53	53	53	55
Dimensions and weights**						
Length		mm	2660	2660	2660	3260
Depth		mm	1130	1130	1130	1130
Height		mm	2136	2136	2136	2136
Operating weight		kg	1212	1214	1241	1332

CH: chiller unit; HP: heat pump unit; MCHX: unit with microchannel coils

- (1) External air temperature of 35°C and user-side heat exchanger water inlet-outlet temperature of 12-7°C. Values compliant with standard EN 14511
- (2) Outside air temperature 7°C DB, 6°C WB; condenser inlet/outlet water temperature 40/45°C. Values compliant with standard EN 14511
- (3) Cold-side exchanger inlet-outlet water temperature *-7°C; Hot-side exchanger inlet-outlet water temperature *-45°C Values compliant with standard EN 14511
- (4) Unit operating at rated capacity, with no accessories of any kind - external air temperature 35°C and water input/output temperature from/to heat exchanger and user equal to 12/7°C. Values taken by measurements made in accordance with standard ISO 3744 and the Eurovent certification programme, where applicable. Binding values See NOISE LEVELS section.
- (5) Values obtained from the sound power level (conditions: note 4), related to a distance of 10 m from the unit in free field with directivity factor Q=2. Non-binding values See NOISE LEVELS section.
- (6) Theoretical values referred to the basic unit. The amount of gas actually charged in the unit may differ.
- (7) Approximate value. The minimum capacity reached by the unit depends on the operating conditions. The value shown may not be suitable for calculating the minimum volume of water: to do this, consult the "Minimum water content in the system" section.

** Basic unit without included accessories

			10.4	12.4	14.4	16.4
Cooling						
Refrigeration capacity	(1)	kW	101.2	119	136.8	166.4
Total absorbed power	(1)	kW	31.8	38.6	45.4	53.6
EER	(1)		3.18	3.09	3.01	3.11
Heating						
Heating capacity	(2)	kW	104.7	122.7	142.9	168.2
Total absorbed power	(2)	kW	30.7	35.8	41.4	50.1
COP	(2)		3.41	3.43	3.45	3.36
Cooling + Heating						
Refrigeration capacity	(3)	kW	95.6	114.2	139.1	157.5
Heating capacity	(3)	kW	124	148.3	180.3	204.6
Total absorbed power	(3)	kW	28.6	34.3	41.4	47.4
TER	(3)		7.69	7.65	7.72	7.64
Compressors						
Compressors/Circuits		n°	4/2	4/2	4/2	4/2
Minimum capacity reduction step	(7)	%	25	25	25	25
Refrigerant charge	(6)	kg	9.7	10	10	14.2
Fans						
Quantity		n°	2	2	2	4
Total air flow rate		m³/h	41000	41000	41000	82000
Cold-side heat exchanger						
Quantity		n°	1	1	1	1
Water flow rate	(1)	m³/h	17.4	20.5	23.6	28.7
Head loss	(1)	kPa	25	25	30	31
Hot-side heat exchanger						
Quantity		n°	1	1	1	1
Water flow rate	(1)	m³/h	18.2	21.3	24.8	29.2
Head loss	(1)	kPa	16	17	15	20
Noise levels						
Sound power level cooling	(4)	dB(A)	87	87	87	90
Sound pressure level cooling	(5)	dB(A)	55	55	55	58
Dimensions and weights**						
Length		mm	3751	3751	3751	4952
Depth		mm	1130	1130	1130	1130
Height		mm	2405	2405	2405	2405
Operating weight		kg	1831	1854	1870	2476

CH: chiller unit; HP: heat pump unit; MCHX: unit with microchannel coils

- (1) External air temperature of 35°C and user-side heat exchanger water inlet-outlet temperature of 12-7°C. Values compliant with standard EN 14511
(2) Outside air temperature 7°C DB, 6°C WB; condenser inlet/outlet water temperature 40/45°C. Values compliant with standard EN 14511
(3) Cold-side exchanger inlet-outlet water temperature *-7°C; Hot-side exchanger inlet-outlet water temperature *-45°C Values compliant with standard EN 14511
(4) Unit operating at rated capacity, with no accessories of any kind - external air temperature 35°C and water input/output temperature from/to heat exchanger and user equal to 12/7°C. Values taken by measurements made in accordance with standard ISO 3744 and the Eurovent certification programme, where applicable. Binding values See NOISE LEVELS section.
(5) Values obtained from the sound power level (conditions: note 4), related to a distance of 10 m from the unit in free field with directivity factor Q=2. Non-binding values See NOISE LEVELS section.
(6) Theoretical values referred to the basic unit. The amount of gas actually charged in the unit may differ.
(7) Approximate value. The minimum capacity reached by the unit depends on the operating conditions. The value shown may not be suitable for calculating the minimum volume of water: to do this, consult the "Minimum water content in the system" section.

** Basic unit without included accessories

			20.6	22.6
Cooling				
Refrigeration capacity	(1)	kW	203.8	231
Total absorbed power	(1)	kW	70.6	81.6
EER	(1)		2.89	2.83
Heating				
Heating capacity	(2)	kW	203	227.6
Total absorbed power	(2)	kW	64.2	73.2
COP	(2)		3.16	3.11
Cooling + Heating				
Refrigeration capacity	(3)	kW	202.8	233.7
Heating capacity	(3)	kW	264.9	304.6
Total absorbed power	(3)	kW	62.9	72.3
TER	(3)		7.43	7.44
Compressors				
Compressors/Circuits		n°	6/2	6/2
Minimum capacity reduction step	(7)	%	17	17
Refrigerant charge	(6)	kg	22	22
Fans				
Quantity		n°	4	4
Total air flow rate		m³/h	82000	82000
Cold-side heat exchanger				
Quantity		n°	1	1
Water flow rate	(1)	m³/h	35.1	39.8
Head loss	(1)	kPa	32	28
Hot-side heat exchanger				
Quantity		n°	1	1
Water flow rate	(1)	m³/h	34.3	39.1
Head loss	(1)	kPa	19	19
Noise levels				
Sound power level cooling	(4)	dB(A)	90	91
Sound pressure level cooling	(5)	dB(A)	58	59
Dimensions and weights**				
Length		mm	4952	4952
Depth		mm	1130	1130
Height		mm	2405	2405
Operating weight		kg	2680	2710

CH: chiller unit; HP: heat pump unit; MCHX: unit with microchannel coils

- (1) External air temperature of 35°C and user-side heat exchanger water inlet-outlet temperature of 12-7°C. Values compliant with standard EN 14511
(2) Outside air temperature 7°C DB, 6°C WB; condenser inlet/outlet water temperature 40/45°C. Values compliant with standard EN 14511
(3) Cold-side exchanger inlet-outlet water temperature *-7°C; Hot-side exchanger inlet-outlet water temperature *-45°C Values compliant with standard EN 14511
(4) Unit operating at rated capacity, with no accessories of any kind - external air temperature 35°C and water input/output temperature from/to heat exchanger and user equal to 12/7°C. Values taken by measurements made in accordance with standard ISO 3744 and the Eurovent certification programme, where applicable. Binding values See NOISE LEVELS section.
(5) Values obtained from the sound power level (conditions: note 4), related to a distance of 10 m from the unit in free field with directivity factor Q=2. Non-binding values See NOISE LEVELS section.
(6) Theoretical values referred to the basic unit. The amount of gas actually charged in the unit may differ.
(7) Approximate value. The minimum capacity reached by the unit depends on the operating conditions. The value shown may not be suitable for calculating the minimum volume of water: to do this, consult the "Minimum water content in the system" section.

** Basic unit without included accessories

OMICRON Zero S4 SLN

			5.2	6.2	7.2	8.2
Cooling						
Refrigeration capacity	(1)	kW	49.1	57.1	66.5	81
Total absorbed power	(1)	kW	16.7	19.8	24.2	27.5
EER	(1)		2.95	2.89	2.75	2.95
Heating						
Heating capacity	(2)	kW	52.5	61.7	70.8	83.2
Total absorbed power	(2)	kW	15.8	18.4	21.1	24.8
COP	(2)		3.33	3.36	3.36	3.36
Cooling + Heating						
Refrigeration capacity	(3)	kW	48.1	58.3	69	79.5
Heating capacity	(3)	kW	62.3	75.4	89.2	102.8
Total absorbed power	(3)	kW	14.3	17.1	20.3	23.5
TER	(3)		7.73	7.8	7.78	7.77
Compressors						
Compressors/Circuits		n°	2/2	2/2	2/2	2/2
Minimum capacity reduction step	(7)	%	50	50	50	50
Refrigerant charge	(6)	kg	5.2	5.2	5.4	7.3
Fans						
Quantity		n°	4	4	4	6
Total air flow rate		m³/h	22400	22400	22400	33600
Cold-side heat exchanger						
Quantity		n°	1	1	1	1
Water flow rate	(1)	m³/h	8.5	9.8	11.5	13.9
Head loss	(1)	kPa	17	22	18	24
Hot-side heat exchanger						
Quantity		n°	1	1	1	1
Water flow rate	(1)	m³/h	9.2	10.6	12.4	14.5
Head loss	(1)	kPa	12	12	13	14
Noise levels						
Sound power level cooling	(4)	dB(A)	83	83	83	84
Sound pressure level cooling	(5)	dB(A)	51	51	51	52
Dimensions and weights**						
Length		mm	2660	2660	2660	3260
Depth		mm	1130	1130	1130	1130
Height		mm	2136	2136	2136	2136
Operating weight		kg	1222	1224	1253	1346

CH: chiller unit; HP: heat pump unit; MCHX: unit with microchannel coils

- (1) External air temperature of 35°C and user-side heat exchanger water inlet-outlet temperature of 12-7°C. Values compliant with standard EN 14511
(2) Outside air temperature 7°C DB, 6°C WB; condenser inlet/outlet water temperature 40/45°C. Values compliant with standard EN 14511
(3) Cold-side exchanger inlet-outlet water temperature *-7°C; Hot-side exchanger inlet-outlet water temperature *-45°C Values compliant with standard EN 14511
(4) Unit operating at rated capacity, with no accessories of any kind - external air temperature 35°C and water input/output temperature from/to heat exchanger and user equal to 12/7°C. Values taken by measurements made in accordance with standard ISO 3744 and the Eurovent certification programme, where applicable. Binding values See NOISE LEVELS section.
(5) Values obtained from the sound power level (conditions: note 4), related to a distance of 10 m from the unit in free field with directivity factor Q=2. Non-binding values See NOISE LEVELS section.
(6) Theoretical values referred to the basic unit. The amount of gas actually charged in the unit may differ.
(7) Approximate value. The minimum capacity reached by the unit depends on the operating conditions. The value shown may not be suitable for calculating the minimum volume of water: to do this, consult the "Minimum water content in the system" section.

** Basic unit without included accessories

			10.4	12.4	14.4	16.4
Cooling						
Refrigeration capacity	(1)	kW	98.6	115.3	132	161.9
Total absorbed power	(1)	kW	32.9	40	47.2	55.3
EER	(1)		2.99	2.89	2.8	2.93
Heating						
Heating capacity	(2)	kW	104.7	122.7	142.9	168.2
Total absorbed power	(2)	kW	30.7	35.8	41.4	50.1
COP	(2)		3.41	3.43	3.45	3.36
Cooling + Heating						
Refrigeration capacity	(3)	kW	95.9	114.1	139.3	157.9
Heating capacity	(3)	kW	124.2	148.3	180.4	204.8
Total absorbed power	(3)	kW	28.5	34.2	41.4	47.3
TER	(3)		7.72	7.67	7.73	7.67
Compressors						
Compressors/Circuits		n°	4/2	4/2	4/2	4/2
Minimum capacity reduction step	(7)	%	25	25	25	25
Refrigerant charge	(6)	kg	9.7	10	10	14.2
Fans						
Quantity		n°	2	2	2	4
Total air flow rate		m³/h	41000	41000	41000	82000
Cold-side heat exchanger						
Quantity		n°	1	1	1	1
Water flow rate	(1)	m³/h	17	19.9	22.7	27.9
Head loss	(1)	kPa	23	23	29	29
Hot-side heat exchanger						
Quantity		n°	1	1	1	1
Water flow rate	(1)	m³/h	18.3	21.3	24.8	29.2
Head loss	(1)	kPa	16	17	15	20
Noise levels						
Sound power level cooling	(4)	dB(A)	83	83	83	87
Sound pressure level cooling	(5)	dB(A)	51	51	51	55
Dimensions and weights**						
Length		mm	3751	3751	3751	4952
Depth		mm	1130	1130	1130	1130
Height		mm	2405	2405	2405	2405
Operating weight		kg	1835	1859	1885	2490

CH: chiller unit; HP: heat pump unit; MCHX: unit with microchannel coils

- (1) External air temperature of 35°C and user-side heat exchanger water inlet-outlet temperature of 12-7°C. Values compliant with standard EN 14511
(2) Outside air temperature 7°C DB, 6°C WB; condenser inlet/outlet water temperature 40/45°C. Values compliant with standard EN 14511
(3) Cold-side exchanger inlet-outlet water temperature *-7°C; Hot-side exchanger inlet-outlet water temperature *-45°C Values compliant with standard EN 14511
(4) Unit operating at rated capacity, with no accessories of any kind - external air temperature 35°C and water input/output temperature from/to heat exchanger and user equal to 12/7°C. Values taken by measurements made in accordance with standard ISO 3744 and the Eurovent certification programme, where applicable. Binding values See NOISE LEVELS section.
(5) Values obtained from the sound power level (conditions: note 4), related to a distance of 10 m from the unit in free field with directivity factor Q=2. Non-binding values See NOISE LEVELS section.
(6) Theoretical values referred to the basic unit. The amount of gas actually charged in the unit may differ.
(7) Approximate value. The minimum capacity reached by the unit depends on the operating conditions. The value shown may not be suitable for calculating the minimum volume of water: to do this, consult the "Minimum water content in the system" section.

** Basic unit without included accessories

			20.6	22.6
Cooling				
Refrigeration capacity	(1)	kW	199.6	224.5
Total absorbed power	(1)	kW	71.7	82.7
EER	(1)		2.78	2.71
Heating				
Heating capacity	(2)	kW	203	227.6
Total absorbed power	(2)	kW	64.19	73.19
COP	(2)		3.16	3.11
Cooling + Heating				
Refrigeration capacity	(3)	kW	202.9	234
Heating capacity	(3)	kW	264.9	304.6
Total absorbed power	(3)	kW	62.8	71.9
TER	(3)		7.45	7.49
Compressors				
Compressors/Circuits		n°	6/2	6/2
Minimum capacity reduction step	(7)	%	17	17
Refrigerant charge	(6)	kg	0	0
Fans				
Quantity		n°	4	4
Total air flow rate		m³/h	82000	82000
Cold-side heat exchanger				
Quantity		n°	1	1
Water flow rate	(1)	m³/h	35.1	39.8
Head loss	(1)	kPa	32	28
Hot-side heat exchanger				
Quantity		n°	1	1
Water flow rate	(1)	m³/h	34.3	39.1
Head loss	(1)	kPa	19	19
Noise levels				
Sound power level cooling	(4)	dB(A)	87	88
Sound pressure level cooling	(5)	dB(A)	55	56
Dimensions and weights**				
Length		mm	4952	4952
Depth		mm	1130	1130
Height		mm	2405	2405
Operating weight		kg	2680	2710

CH: chiller unit; HP: heat pump unit; MCHX: unit with microchannel coils

- (1) External air temperature of 35°C and user-side heat exchanger water inlet-outlet temperature of 12-7°C. Values compliant with standard EN 14511
(2) Outside air temperature 7°C DB, 6°C WB; condenser inlet/outlet water temperature 40/45°C. Values compliant with standard EN 14511
(3) Cold-side exchanger inlet-outlet water temperature *-7°C; Hot-side exchanger inlet-outlet water temperature *-45°C Values compliant with standard EN 14511
(4) Unit operating at rated capacity, with no accessories of any kind - external air temperature 35°C and water input/output temperature from/to heat exchanger and user equal to 12/7°C. Values taken by measurements made in accordance with standard ISO 3744 and the Eurovent certification programme, where applicable. Binding values See NOISE LEVELS section.
(5) Values obtained from the sound power level (conditions: note 4), related to a distance of 10 m from the unit in free field with directivity factor Q=2. Non-binding values See NOISE LEVELS section.
(6) Theoretical values referred to the basic unit. The amount of gas actually charged in the unit may differ.
(7) Approximate value. The minimum capacity reached by the unit depends on the operating conditions. The value shown may not be suitable for calculating the minimum volume of water: to do this, consult the "Minimum water content in the system" section.

** Basic unit without included accessories

ECODESIGN

INTRODUCTION

The Ecodesign/ErP Directive (2009/125/EC) lays down new standards for more efficient energy use.

The Directive contains various regulations; as regards chiller products and heat pumps, the regulations of interest are the following:

- Regulation 2013/813, for small heat pumps ($P_{\text{design}} \leq 400$ kW)
- Regulation 2016/2281, for chillers and heat pumps with $P_{\text{design}} > 400$ kW
- Regulation 2013/811, for heat pumps with $P_{\text{design}} \leq 70$ kW.

The last-mentioned regulation (2013/811) regards the labelling (Ecolabel certification) of small heat pumps.

The other two regulations (2013/813 and 2016/2281) set seasonal efficiency targets that the products must comply with to be sold and installed in the European Union (essential requirement for CE marking).

These efficiency limits are defined through ratios, which are respectively:

- η_{sh} (SCOP), with reference to regulation 2013/813
- η_{sc} (SEER) for comfort applications and SEPR for process applications, with reference to regulation 2016/2281.

As regards regulation 2016/2281, with effect from 1st January 2021, the required minimum efficiency limit will be raised (Tier 2) from the current threshold (Tier 1).

The figure below schematically illustrates the correspondence between product and reference energy ratio.

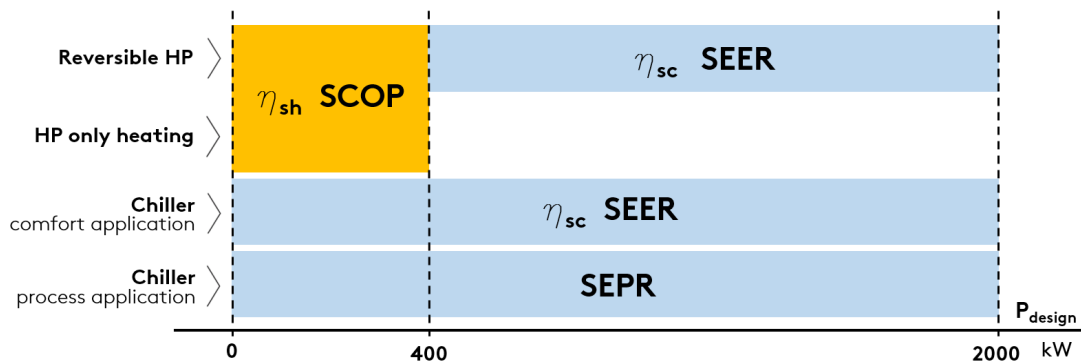

Some notes and clarifications:

For comfort applications, regulation 2016/2281 sets the η_{sc} (SEER) ratio in two different operating conditions:

- SEER calculated with machine inlet/outlet water temperature of 12/7°C (low temperature application),
- SEER calculated with machine inlet/outlet water temperature of 23/18°C (medium temperature application).

The minimum efficiency requirement is the same, but can be met at condition 12/7°C or at condition 23/18°C, depending on the application envisaged for the machine.

Regulation 2013/813 distinguishes two different types: at low temperature and at medium temperature.

The following refer to the application at low temperature: (low temperature application) all heat pumps whose maximum delivery temperature for heating purposes is lower than 52°C with source at temperature of -7°C and -8°C wet bulb (air-water unit) or inlet 10°C (water-water unit), at the reference design conditions for an average climate. For these, the efficiency ratio is "low temperature application" (outlet water temperature 35°C).

For all the other heat pumps, the efficiency ratio is related to "medium temperature application" (outlet water temperature 55°C).

The ratios must be calculated according to the reference European heating season in average climatic conditions.

The minimum efficiency requirements set by the regulations are indicated below.

REGULATION 2016/2281, comfort application

TYPE OF UNIT		MINIMUM REQUIREMENT			
		Tier 1		Tier 2 (2021)	
SOURCE	Pdesign	η_{sc} [%]	SEER	η_{sc} [%]	SEER
air	< 400kW	149	3,8	161	4,1
air	\geq 400kW	161	4,1	179	4,55
water	< 400kW	196	4,975	200	5,075
water	\geq 400kW and < 1500kW	227	5,75	252	6,375
water	\geq 1500kW	245	6,2	272	6,875

REGULATION 2016/2281, process application

TYPE OF UNIT		MINIMUM REQUIREMENT	
		Tier 1	Tier 2 (2021)
SOURCE	Pdesign	SEPR	SEPR
air	< 400kW	4,5	5
air	\geq 400kW	5	5,5
water	< 400kW	6,5	7
water	\geq 400kW and < 1500kW	7,5	8
water	\geq 1500kW	8	8,5

REGULATION 2013/813

SOURCE	APPLICATION	MINIMUM REQUIREMENT	
		η_{sh} [%]	SCOP
air	low temperature application	125	3,2
water	low temperature application	125	3,325
air	medium temperature application	110	2,825
water	medium temperature application	110	2,95

The conformity of the product must be checked according to the type of application, whether comfort or process, and at the required outlet water temperature.

The two schematic tables below, respectively for comfort application and for process application, indicate the reference of the required conformity according to the type of product and the set point temperature (reference to regulations 2016/2281 and 2013/813).

Important note: for mixed comfort and process applications, the reference application for conformity is the comfort application.

COMFORT APPLICATION

PRODUCT	OUTLET WATER TEMPERATURE	COMPLIANCE INDEX	REGULATION
Chiller	< 18°C	SEER/η _{sc} low temperature application	2016/2281
	≥ 18°C	SEER/η _{sc} medium temperature application	2016/2281
Heat pumps (reversible and only heating) P_{design} ≤ 400kW		SCOP/η _{sh}	2013/813
Reversible heat pumps P_{design} > 400kW	< 18°C	SEER/η _{sc} low temperature application	2016/2281
	≥ 18°C	SEER/η _{sc} medium temperature application	2016/2281
Heat pumps only heating P_{design} > 400kW		-	-

- = exemption from Ecodesign

PROCESS APPLICATION

PRODUCT	OUTLET WATER TEMPERATURE	COMPLIANCE INDEX	REGULATION
Chiller	≥ +2°C , ≤ 12°C	SEPR	2016/2281
	> 12°C	-	-
	> -8°C , < +2°C	-	-

- = exemption from Ecodesign

Some specifications and notes follow.

Partly completed machinery

The term partly completed machinery refers to all units without a user-side or source-side heat exchanger, and therefore to all LC, LE, LC/HP and LE/HP versions. Since these are "non-complete" machines, conformity with Ecodesign depends on combination with the remote heat exchanger.

All the partly completed machinery is CE marked and accompanied by a declaration of conformity. Installation in European Union countries is therefore allowed; correct selection and installation of the remote heat exchanger must be ensured, in accordance with the above cases.

EC fans:

The only option that positively affects the performance of the unit, by increasing its seasonal energy efficiency ratio, is the VEC accessory.

A unit equipped with EC fans has a higher SEER (η_{sc}) than the configuration with standard fans.

OMICRON ZERO S4

The Ecodesign/ErP Directive (2009/125/EC) lays down new standards for more efficient energy use. Several regulations are part of the directive, and set mandatory seasonal efficiency targets for sale in the European Union.

The unit therefore, to be CE marked and sold in the EU market, must comply with the minimum requirements imposed by the regulations in question.

Regarding the Omicron Zero S4 range, the reference regulations in the various configurations are:

- Regulation 2013/813, for heat pump Pdesign \leq 400 kW

Minimum efficiency requirements are imposed through seasonal energy efficiency indices, respectively:

- η_{sh} (SCOP), with reference to regulation 2013/813

With reference to the Omicron Zero S4 range, below is a list of concerned regulations relating to the different units in their various configurations:

OMICRON Zero S4

and

OMICRON Zero S4 SLN

- all versions up to size 22.6 regulation 2013/813,

The tables below give information on the conformity of the units and the seasonal energy performance ratios with regard to the reference regulation.

OMICRON Zero S4

			5.2	6.2	7.2	8.2
REGULATION 2013/813			-			
Pdesign	(1)	kW	46.74	53.89	64.07	73.68
COMFORT						
Standard Unit						
ηsh	(1)	%	134.92	133.44	130.16	133.96
SCOP LT	(1)		3.45	3.41	3.33	3.42
Unit with EC fans (VEC)						
ηsh	(1)	%	137.48	138.96	139.24	142
SCOP LT	(1)		3.51	3.55	3.56	3.63
Standard Unit						
ηsh	(1)	%	113.4		113	113.8
SCOP MT	(1)		2.91		2.9	2.92
Unit with EC fans (VEC)						
ηsh	(1)	%	120	120.2	120	121
SCOP MT	(1)		3.08			3.1

			10.4	12.4	14.4	16.4
REGULATION 2013/813			-			
Pdesign	(1)	kW	92.84	108.3	119.5	154.5
COMFORT						
Standard Unit						
ηsh	(1)	%	144.36	147.76	153.72	147.4
SCOP LT	(1)		3.68	3.77	3.92	3.76
Unit with EC fans (VEC)						
ηsh	(1)	%	150.36	151.08	160.04	155
SCOP LT	(1)		3.83	3.85	4.08	3.95
Standard Unit						
ηsh	(1)	%	123.84	129.6	129	125
SCOP MT	(1)		3.17	3.32	3.3	3.2
Unit with EC fans (VEC)						
ηsh	(1)	%	127.66	132.6	133.8	131.76
SCOP MT	(1)		3.27	3.39	3.42	3.37

			20.6	22.6
REGULATION 2013/813			-	
Pdesign	(1)	kW	181.4	190.9
COMFORT				
Standard Unit				
ηsh	(1)	%	146.8	147.1
SCOP LT	(1)		3.74	3.75
Unit with EC fans (VEC)				
ηsh	(1)	%	154.9	155
SCOP LT	(1)		3.95	
Standard Unit				
ηsh	(1)	%	123.4	123
SCOP MT	(1)		3.16	3.15
Unit with EC fans (VEC)				
ηsh	(1)	%	127.4	127
SCOP MT	(1)		3.26	3.25

Y = unit in compliance with Ecodesign at the indicated condition. N = unit not in compliance with Ecodesign at the indicated condition: it can be installed only in non-EU countries.

- (1) User-side heat exchanger water inlet/outlet temperature 30/35°C, Average climate profile, with reference to regulation 2013/813 and norm EN 14825.
 (2) Energy efficiency class with reference to regulation 2013/811 (low temperature applications).

OMICRON Zero S4 SLN

			5.2	6.2	7.2	8.2
REGULATION 2013/813			-			
Pdesign	(1)	kW	46.74	53.89	64.07	73.68
COMFORT						
Standard Unit						
ηsh	(1)	%	134.92	133.44	130.16	133.96
SCOP LT	(1)		3.45	3.41	3.33	3.42
Unit with EC fans (VEC)						
ηsh	(1)	%	137.48	138.96	139.24	142
SCOP LT	(1)		3.51	3.55	3.56	3.63
Standard Unit						
ηsh	(1)	%	113.4		113	113.8
SCOP MT	(1)		2.91		2.9	2.92
Unit with EC fans (VEC)						
ηsh	(1)	%	120	120.2	120	121
SCOP MT	(1)		3.08			3.1

			10.4	12.4	14.4	16.4
REGULATION 2013/813			-			
Pdesign	(1)	kW	92.84	108.3	119.5	154.5
COMFORT						
Standard Unit						
ηsh	(1)	%	144.36	147.76	153.72	147.4
SCOP LT	(1)		3.68	3.77	3.92	3.76
Unit with EC fans (VEC)						
ηsh	(1)	%	150.36	151.08	160.04	155
SCOP LT	(1)		3.83	3.85	4.08	3.95
Standard Unit						
ηsh	(1)	%	123.84	129.6	129	125
SCOP MT	(1)		3.17	3.32	3.3	3.2
Unit with EC fans (VEC)						
ηsh	(1)	%	127.66	132.6	133.8	131.76
SCOP MT	(1)		3.27	3.39	3.42	3.37

			20.6	22.6
REGULATION 2013/813			-	
Pdesign	(1)	kW	181.4	190.9
COMFORT				
Standard Unit				
ηsh	(1)	%	146.8	147.1
SCOP LT	(1)		3.74	3.75
Unit with EC fans (VEC)				
ηsh	(1)	%	154.9	155
SCOP LT	(1)		3.95	
Standard Unit				
ηsh	(1)	%	123.4	123
SCOP MT	(1)		3.16	3.15
Unit with EC fans (VEC)				
ηsh	(1)	%	127.4	127
SCOP MT	(1)		3.26	3.25

Y = unit in compliance with Ecodesign at the indicated condition. N = unit not in compliance with Ecodesign at the indicated condition: it can be installed only in non-EU countries.

- (1) User-side heat exchanger water inlet/outlet temperature 30/35°C, Average climate profile, with reference to regulation 2013/813 and norm EN 14825.
 (2) Energy efficiency class with reference to regulation 2013/811 (low temperature applications).

ELECTRICAL SPECIFICATIONS

OMICRON Zero S4

			5.2	6.2	7.2	8.2	10.4
General electrical specifications							
Max. absorbed power (FLI)	(1)	kW	25	29	35	40	50
Max. absorbed current (FLA)	(1)	A	52	58	70	81	95
Nominal current (Inom)	(2)	A	30	36	46	53	59
cosφ standard unit	(2)		0.79	0.79	0.74	0.74	0.78
Nominal current with power factor correction (Inom)	(2)	A	24	29	35	40	47
cosφ unit with power factor correction	(2)		0.98	0.97	0.97	0.98	0.98
Maximum inrush current (MIC)	(3)	A	177	180	180	233	220
Maximum inrush current with soft-starter (MIC)	(4)	A	113	117	120	154	158
Power supply		V/ph/Hz	400/3~+N/50				
Power supply for auxiliary circuits		mm ²	230-24/1~/50				
Suggested line section	(5)	mm ²	4x25+1G16	4x25+1G16	4x35+1G25	4x35+1G25	4x50+1G25
Suggested line protection	(6)		NH00gG 80A	NH00gG 80A	NH00gG 100A	NH00gG 100A	NH00gG 125A
Electrical specifications for fans							
Rated power of standard fan	(1)	n° x kW	4 x 0,5	4 x 0,5	4 x 0,5	6 x 0,5	2 x 1,5
Rated current of standard fan	(1)	n° x A	4 x 2,1	4 x 2,1	4 x 2,1	6 x 2,1	2 x 3,4
Rated power of EC fan	(2)	n° x kW	4 x 0,3	4 x 0,3	4 x 0,3	6 x 0,3	2 x 1,3
Rated current of EC fan	(2)	n° x A	4 x 2,2	4 x 2,2	4 x 2,2	6 x 2,2	2 x 1,9
Rated power of oversize EC fan	(2)	n° x kW	4 x 0,5	4 x 0,5	4 x 0,5	6 x 0,5	2 x 2,9
Rated current of oversized EC fan	(2)	n° x A	4 x 2,2	4 x 2,2	4 x 2,2	6 x 2,2	2 x 4,4

			12.4	14.4	16.4	20.6	22.6
General electrical specifications							
Max. absorbed power (FLI)	(1)	kW	58	70	81	106	118
Max. absorbed current (FLA)	(1)	A	107	131	150	200	218
Nominal current (Inom)	(2)	A	70	90	109	139	156
cosφ standard unit	(2)		0.76	0.73	0.73	0.73	0.73
Nominal current with power factor correction (Inom)	(2)	A	57	69	81	106	116
cosφ unit with power factor correction	(2)		0.97	0.96	0.98	0.96	0.98
Maximum inrush current (MIC)	(3)	A	229	241	302	310	370
Maximum inrush current with soft-starter (MIC)	(4)	A	171	187	234	257	306
Power supply		V/ph/Hz	400/3~+N/50				
Power supply for auxiliary circuits		mm ²	230-24/1~/50				
Suggested line section	(5)	mm ²	4x70+1G35	4x70+1G35	4x95+1G50	**non tradotto**	**non tradotto**
Suggested line protection	(6)		NH00gG 160A	NH00gG 160A	NH1gG 200A	NH1gG 250A	NH2gG 315A
Electrical specifications for fans							
Rated power of standard fan	(1)	n° x kW	2 x 1,5	2 x 1,5	4 x 1,5	4 x 1,5	4 x 1,5
Rated current of standard fan	(1)	n° x A	2 x 3,4	2 x 3,4	4 x 3,4	4 x 3,4	4 x 3,4
Rated power of EC fan	(2)	n° x kW	2 x 1,3	2 x 1,3	4 x 1,3	4 x 1,3	4 x 1,3
Rated current of EC fan	(2)	n° x A	2 x 1,9	2 x 1,9	4 x 1,9	4 x 1,9	4 x 1,9
Rated power of oversize EC fan	(2)	n° x kW	2 x 2,9	2 x 2,9	4 x 2,9	4 x 2,9	4 x 2,9
Rated current of oversized EC fan	(2)	n° x A	2 x 4,4	2 x 4,4	4 x 4,4	4 x 4,4	4 x 4,4

- (1) Data regarding the unit without accessories working in maximum power absorption conditions
- (2) Datum related to the unit without accessories working in standard conditions (A35°C; W12-7°C)
- (3) Maximum effective RMS value of the current when the last compressor starts (FLA of the entire unit - FLA of the largest compressor + LRA of the largest compressor)
- (4) Maximum effective RMS value of the current when the last compressor starts (FLA of the entire unit - FLA of the largest compressor + 0.6 x LRA of the largest compressor)
- (5) These values are determined for cables with operating temperature of 40°C, EPR insulation and a line with a maximum length of 50m. The line section must be determined by a qualified technician based on the protection devices, the length of the line, the type of cable used and the type of installation.
- (6) The correct line protection part must be determined by a qualified technician based on the length of the line, the type of cable used and the type of installation.

OMICRON Zero S4 SLN

			5.2	6.2	7.2	8.2	10.4
General electrical specifications							
Max. absorbed power (FLI)	(1)	kW	25	29	35	40	50
Max. absorbed current (FLA)	(1)	A	52	58	70	81	95
Nominal current (Inom)	(2)	A	30	36	46	53	59
cosφ standard unit	(2)		0.79	0.79	0.74	0.74	0.78
Nominal current with power factor correction (Inom)	(2)	A	24	29	35	40	47
cosφ unit with power factor correction	(2)		0.98	0.97	0.97	0.98	0.98
Maximum inrush current (MIC)	(3)	A	177	180	180	233	220
Maximum inrush current with soft-starter (MIC)	(4)	A	113	117	120	154	158
Power supply		V/ph/Hz	400/3~+N/50				
Power supply for auxiliary circuits		mm ²	230-24/1~/50				
Suggested line section	(5)	mm ²	4x25+1G16	4x25+1G16	4x35+1G25	4x35+1G25	4x50+1G25
Suggested line protection	(6)		NH00gG 80A	NH00gG 80A	NH00gG 100A	NH00gG 100A	NH00gG 125A
Electrical specifications for fans							
Rated power of standard fan	(1)	n° x kW	4 x 0,5	4 x 0,5	4 x 0,5	6 x 0,5	2 x 1,5
Rated current of standard fan	(1)	n° x A	4 x 2,1	4 x 2,1	4 x 2,1	6 x 2,1	2 x 3,4
Rated power of EC fan	(2)	n° x kW	4 x 0,3	4 x 0,3	4 x 0,3	6 x 0,3	2 x 1,3
Rated current of EC fan	(2)	n° x A	4 x 2,2	4 x 2,2	4 x 2,2	6 x 2,2	2 x 1,9
Rated power of oversize EC fan	(2)	n° x kW	4 x 0,5	4 x 0,5	4 x 0,5	6 x 0,5	2 x 2,9
Rated current of oversized EC fan	(2)	n° x A	4 x 2,2	4 x 2,2	4 x 2,2	6 x 2,2	2 x 4,4

			12.4	14.4	16.4	20.6	22.6
General electrical specifications							
Max. absorbed power (FLI)	(1)	kW	58	70	81	106	118
Max. absorbed current (FLA)	(1)	A	107	131	150	200	218
Nominal current (Inom)	(2)	A	70	90	109	139	156
cosφ standard unit	(2)		0.76	0.73	0.73	0.73	0.73
Nominal current with power factor correction (Inom)	(2)	A	57	69	81	106	116
cosφ unit with power factor correction	(2)		0.97	0.96	0.98	0.96	0.98
Maximum inrush current (MIC)	(3)	A	229	241	302	310	370
Maximum inrush current with soft-starter (MIC)	(4)	A	171	187	234	257	306
Power supply		V/ph/Hz	400/3~+N/50				
Power supply for auxiliary circuits		mm ²	230-24/1~/50				
Suggested line section	(5)	mm ²	4x70+1G35	4x70+1G35	4x95+1G50	**non tradotto**	**non tradotto**
Suggested line protection	(6)		NH00gG 160A	NH00gG 160A	NH1gG 200A	NH1gG 250A	NH2gG 315A
Electrical specifications for fans							
Rated power of standard fan	(1)	n° x kW	2 x 1,5	2 x 1,5	4 x 1,5	4 x 1,5	4 x 1,5
Rated current of standard fan	(1)	n° x A	2 x 3,4	2 x 3,4	4 x 3,4	4 x 3,4	4 x 3,4
Rated power of EC fan	(2)	n° x kW	2 x 1,3	2 x 1,3	4 x 1,3	4 x 1,3	4 x 1,3
Rated current of EC fan	(2)	n° x A	2 x 1,9	2 x 1,9	4 x 1,9	4 x 1,9	4 x 1,9
Rated power of oversize EC fan	(2)	n° x kW	2 x 2,9	2 x 2,9	4 x 2,9	4 x 2,9	4 x 2,9
Rated current of oversized EC fan	(2)	n° x A	2 x 4,4	2 x 4,4	4 x 4,4	4 x 4,4	4 x 4,4

- (1) Data regarding the unit without accessories working in maximum power absorption conditions
- (2) Datum related to the unit without accessories working in standard conditions (A35°C; W12-7°C)
- (3) Maximum effective RMS value of the current when the last compressor starts (FLA of the entire unit - FLA of the largest compressor + LRA of the largest compressor)
- (4) Maximum effective RMS value of the current when the last compressor starts (FLA of the entire unit - FLA of the largest compressor + 0.6 x LRA of the largest compressor)
- (5) These values are determined for cables with operating temperature of 40°C, EPR insulation and a line with a maximum length of 50m. The line section must be determined by a qualified technician based on the protection devices, the length of the line, the type of cable used and the type of installation.
- (6) The correct line protection part must be determined by a qualified technician based on the length of the line, the type of cable used and the type of installation.

USER-SIDE EXCHANGER FLOW RATE FIELDS

The units are sized and optimized for the following nominal conditions: external air 35°C, inlet-outlet of the user-side exchanger 12/7°C.

The units can work at design conditions different from nominal conditions, provided that:

- the design condition falls within the operating limits specified below
- the unit is equipped with all the accessories necessary for operation (e.g. brine kit, fan speed adjuster, HAT)
- the flow rate at design conditions (that is, of the specific application) must always come within the allowed flow rate ranges specified below. If the design conditions require a water flow rate that does not come within the allowed operating range, you must contact our sales department that will identify the most suitable solution for the specific application.

OMICRON Zero S4

	Cold-side heat exchanger		Hot-side heat exchanger	
	Qmin	Qmax	Qmin	Qmax
	m ³ /h	m ³ /h	m ³ /h	m ³ /h
5.2	4,3	14,2	5,4	16,3
6.2	4,3	14,2	6,5	19,6
7.2	5,9	20,1	7,9	23,7
8.2	5,9	20,1	8,9	26,8
10.4	8,9	26,7	10,8	32,3
12.4	10,6	33,9	12,5	37,4
14.4	10,6	33,9	15	44,9
16.4	14	41,9	15	44,9
18.6	15,2	50,2	19,3	57,8
20.6	15,2	50,2	22,7	68,1
22.6	17,6	52,9	25,9	77,7

OPERATING LIMITS

COOLING

OMICRON Zero S4 / OMICRON Zero S4SLN

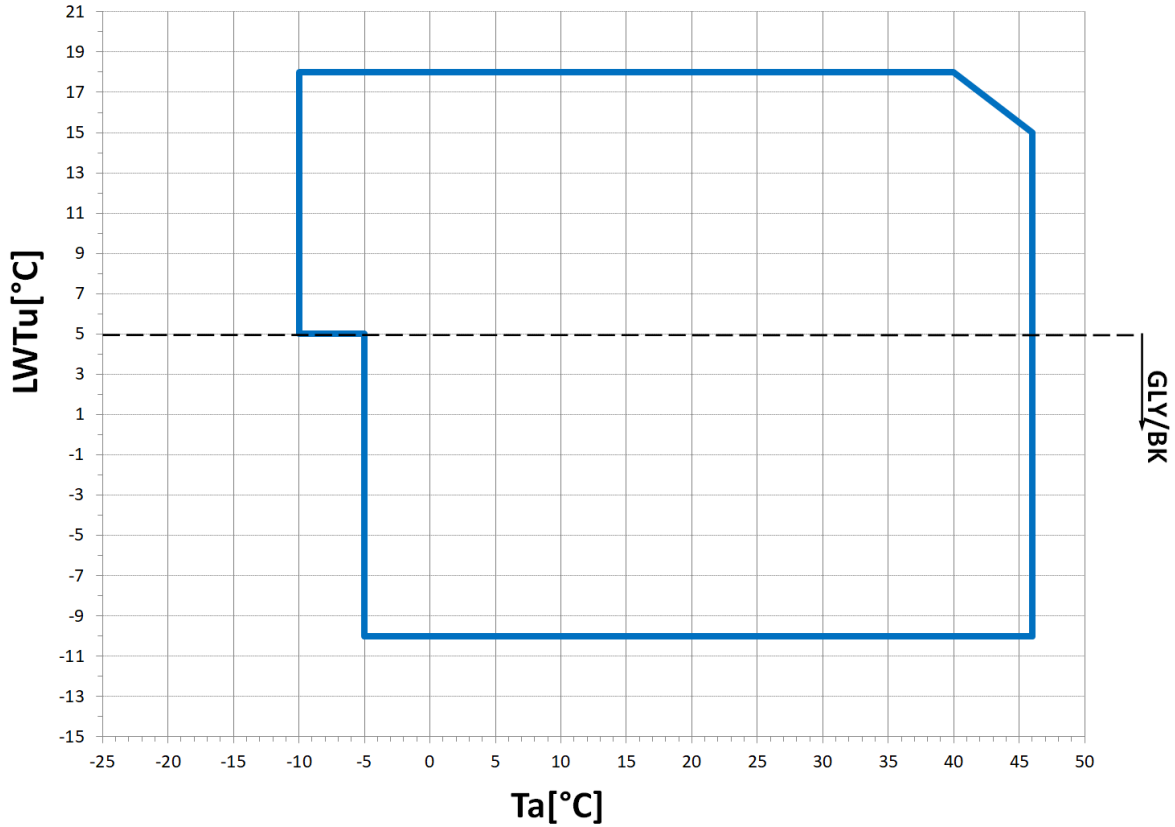

Ta: external air temperature

LWTu: water outlet temperature from the cold-side exchanger

LWTr: water outlet temperature from the hot-side exchanger

LW: in the indicated area, the unit can work only where there is no wind

FU: in the indicated area, the control could actuate a forced capacity reduction of the compressors so as to prevent tripping of the safety devices

Working envelope not available for 2 compressors units

BK: For LWTu below +3°C, it is mandatory to fit the "Brine Kit" accessory

RAV: For Ta lower than or equal to 0 ° C it is mandatory to provide the RAV accessory "Electric resistance for condensate drain pan"

IDRO: In the event of extended use within the area indicated, we recommend using finned coil packs treated with the hydrophilic coating.

For LWTu below +5°C, it is compulsory to use suitable percentages of antifreeze additives (glycols) to prevent ice formation in the exchanger.

The inlet and outlet temperatures of the user-side exchanger must be given on ordering to allow correct setting of the alarm parameters and verification of the sizing of the expansion valve.

The cooling set point can then be changed by the customer in an interval that, compared to the set point given on ordering, ranges from -1K up to the maximum temperature allowed by the above-stated operating limits.

The unit will be optimized to work at the set point temperatures given on ordering. For different set points, the cooling capacity provided and the level of efficiency of the machine could decrease and move away from these conditions.

HEATING

OMICRON Zero S4 / OMICRON Zero S4SLN

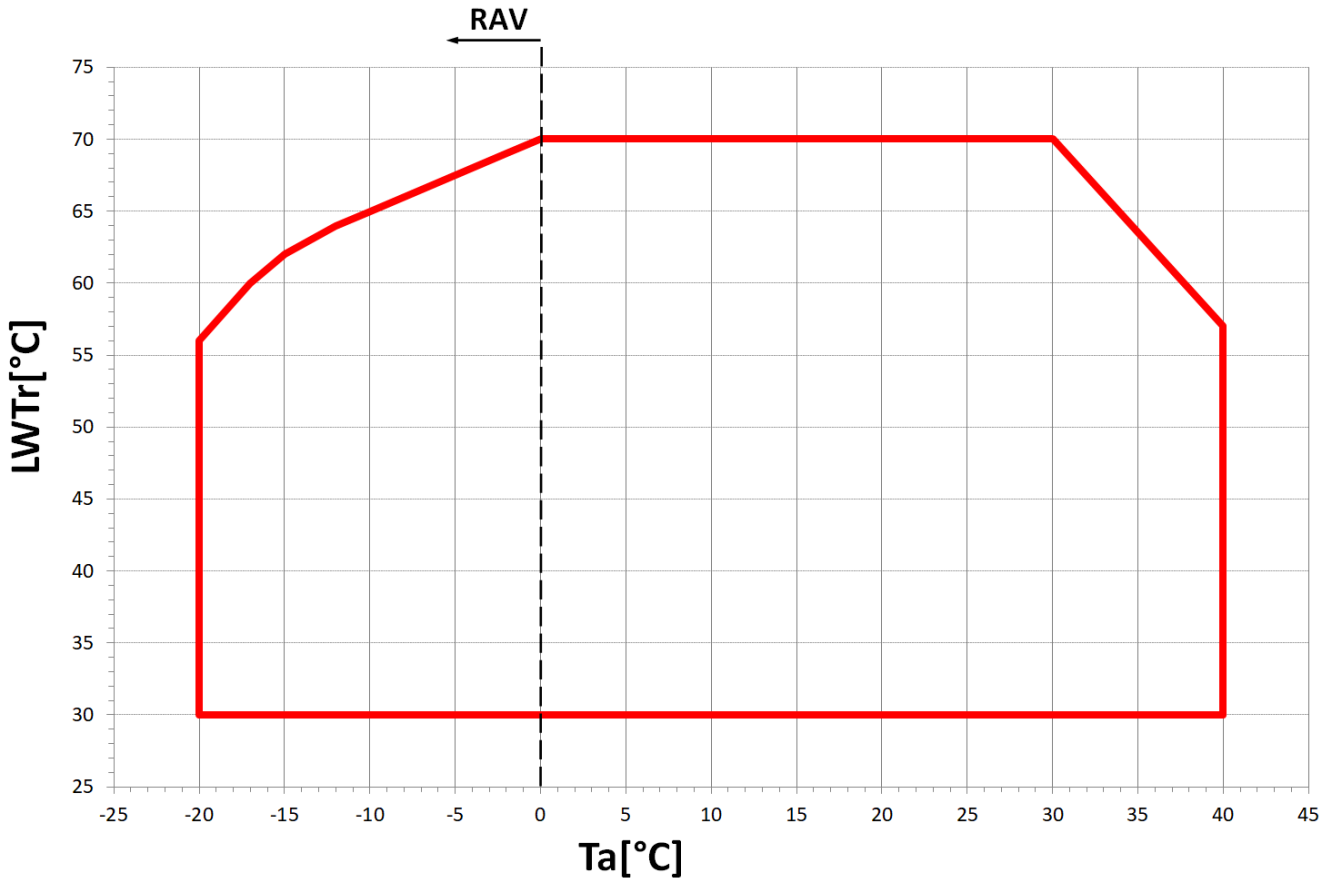

Ta: external air temperature

LWTu: water outlet temperature from the cold-side exchanger

LWTr: water outlet temperature from the hot-side exchanger

LW: in the indicated area, the unit can work only where there is no wind

FU: in the indicated area, the control could actuate a forced capacity reduction of the compressors so as to prevent tripping of the safety devices

Working envelope not available for 2 compressors units

BK: For LWTu below +3°C, it is mandatory to fit the "Brine Kit" accessory

RAV: For Ta lower than or equal to 0 ° C it is mandatory to provide the RAV accessory "Electric resistance for condensate drain pan"

For LWTu below +5°C, it is compulsory to use suitable percentages of antifreeze additives (glycols) to prevent ice formation in the exchanger.

The inlet and outlet temperatures of the user-side exchanger must be given on ordering to allow correct setting of the alarm parameters and verification of the sizing of the expansion valve.

The cooling set point can then be changed by the customer in an interval that, compared to the set point given on ordering, ranges from -1K up to the maximum temperature allowed by the above-stated operating limits.

The unit will be optimized to work at the set point temperatures given on ordering. For different set points, the cooling capacity provided and the level of efficiency of the machine could decrease and move away from these conditions.

OPERATING LIMITS

COOLING+HEATING

OMICRON Zero S4 / OMICRON Zero S4SLN

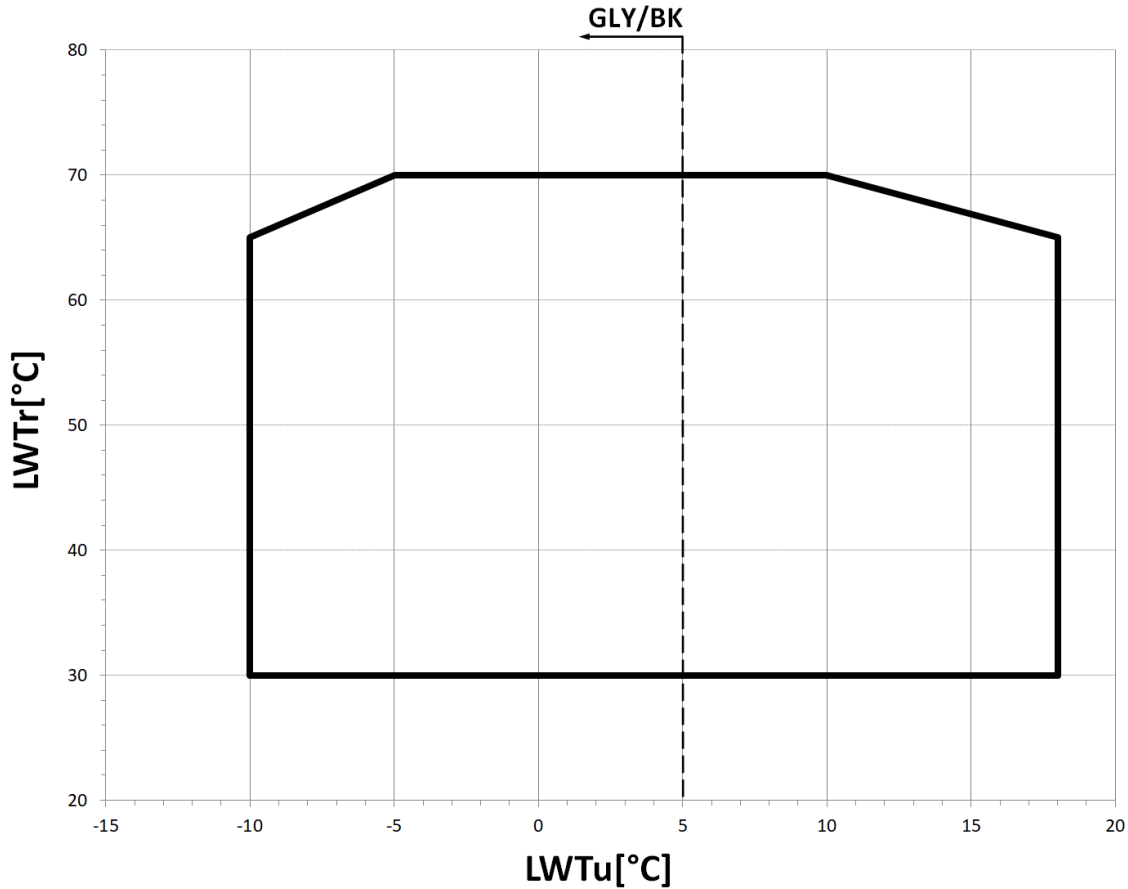

- Ta:** external air temperature
- LWTu:** water outlet temperature from the cold-side exchanger
- LWTr:** water outlet temperature from the hot-side exchanger
- LW:** in the indicated area, the unit can work only where there is no wind
- FU:** in the indicated area, the control could actuate a forced capacity reduction of the compressors so as to prevent tripping of the safety devices
Working envelope not available for 2 compressors units
- BK:** For LWTu below +3°C, it is mandatory to fit the "Brine Kit" accessory
- RAV:** For Ta lower than or equal to 0 ° C it is mandatory to provide the RAV accessory "Electric resistance for condensate drain pan"
- IDRO:** In the event of extended use within the area indicated, we recommend using finned coil packs treated with the hydrophilic coating.

For LWTu below +5°C, it is compulsory to use suitable percentages of antifreeze additives (glycols) to prevent ice formation in the exchanger.

The inlet and outlet temperatures of the user-side exchanger must be given on ordering to allow correct setting of the alarm parameters and verification of the sizing of the expansion valve.

The cooling set point can then be changed by the customer in an interval that, compared to the set point given on ordering, ranges from -1K up to the maximum temperature allowed by the above-stated operating limits.

The unit will be optimized to work at the set point temperatures given on ordering. For different set points, the cooling capacity provided and the level of efficiency of the machine could decrease and move away from these conditions.

NOISE LEVELS

OMICRON Zero S4

Octave bands [dB]

	Total																	
	63 Hz		125 Hz		250 Hz		500 Hz		1000 Hz		2000 Hz		4000 Hz		8000 Hz		[dB(A)]	
	Lw	Lp	Lw	Lp	Lw	Lp	Lw	Lp	Lw	Lp	Lw	Lp	Lw	Lp	Lw	Lp	Lw	Lp
5.2	86	54	96	56	88	56	83	51	75	37	69	37	67	35	62	30	85	53
6.2	86	54	96	56	88	56	83	51	75	37	69	37	67	35	62	30	85	53
7.2	86	54	96	56	88	56	83	51	75	37	69	37	67	35	62	30	85	53
8.2	88	56	98	58	90	58	85	53	77	39	71	39	69	37	64	32	87	55
10.4	88	56	97	57	89	57	85	53	76	39	71	39	69	37	63	31	87	55
12.4	88	56	97	57	89	57	85	53	77	39	71	39	69	37	63	31	87	55
14.4	88	56	98	58	90	58	85	53	77	39	71	39	69	37	64	32	87	55
16.4	91	59	100	60	92	60	88	56	79	42	74	42	72	40	66	34	90	58
20.6	91	59	102	70	92	60	84	52	81	49	77	45	70	38	67	35	90	58
22.6	92	59	103	71	93	61	85	54	82	50	78	46	71	39	68	36	91	59

Reference conditions: outside air temperature 35°C; input/output water temperature into/from user-side heat exchanger 12/7°C; unit operating at rated capacity, without any option.

Lw: sound power levels. Values obtained from measures taken according to standard ISO 3744. Lw_tot is the only binding value.

Lp: sound pressure levels. Binding values starting from noise power levels referred to a distance of 10 m from the unit; source installed on a reflective surface and in ideal free field conditions with directivity factor Q=2. Non-binding values

The acoustic data are related to standard conditions in referable and reproducible operating conditions. All data with the exception of Lw_tot are provided for illustrative purposes only and can not be used for forecasting purposes or for the verification of binding limits. With special reference to noise emissions, the Manufacturer takes liability for their conformity, limited to the declared Lw_tot value. Any and all other Manufacturer's liability for the impact of such emissions in relation to the location of the machine and other conditions related to machine installation is excluded. The environment and the installation conditions, as well as the operating modes, can alter the sound emissions. Any assessment concerning these conditions falls within the area of competence of the plant designer and/or the fitter.

OMICRON Zero S4 SLN

Octave bands [dB]

Total

	63 Hz		125 Hz		250 Hz		500 Hz		1000 Hz		2000 Hz		4000 Hz		8000 Hz		[dB(A)]	
	Lw	Lp	Lw	Lp	Lw	Lp	Lw	Lp	Lw	Lp	Lw	Lp	Lw	Lp	Lw	Lp	Lw	Lp
5.2	84	52	98	66	82	50	74	42	67	35	60	28	60	28	56	24	83	51
6.2	84	52	98	66	82	50	74	42	67	35	60	28	60	28	56	24	83	51
7.2	84	52	98	66	83	51	75	43	67	35	61	29	61	29	57	25	83	51
8.2	85	53	99	67	83	51	75	44	68	36	62	30	61	29	58	26	84	52
10.4	84	52	98	66	82	50	74	42	67	35	60	28	60	28	56	24	83	51
12.4	84	52	98	66	82	50	74	42	67	35	60	28	60	28	56	24	83	51
14.4	84	52	98	66	82	50	75	43	67	35	61	29	61	29	57	25	83	51
16.4	88	56	102	70	86	54	78	46	71	39	64	32	64	32	60	28	87	55
20.6	88	55	102	69	86	54	78	46	71	38	64	32	64	32	60	28	87	55
22.6	89	55	103	69	87	54	79	46	71	38	65	32	65	32	61	28	88	56

Reference conditions: outside air temperature 35°C; input/output water temperature into/from user-side heat exchanger 12/7°C; unit operating at rated capacity, without any option.

Lw: sound power levels. Values obtained from measures taken according to standard ISO 3744. Lw_tot is the only binding value.

Lp: sound pressure levels. Binding values starting from noise power levels referred to a distance of 10 m from the unit; source installed on a reflective surface and in ideal free field conditions with directivity factor Q=2. Non-binding values

The acoustic data are related to standard conditions in referable and reproducible operating conditions. All data with the exception of Lw_tot are provided for illustrative purposes only and can not be used for forecasting purposes or for the verification of binding limits. With special reference to noise emissions, the Manufacturer takes liability for their conformity, limited to the declared Lw_tot value. Any and all other Manufacturer's liability for the impact of such emissions in relation to the location of the machine and other conditions related to machine installation is excluded. The environment and the installation conditions, as well as the operating modes, can alter the sound emissions. Any assessment concerning these conditions falls within the area of competence of the plant designer and/or the fitter.

INSTALLATION ADVICE

The units described in this document are, by nature, strongly affected by the characteristics of the system, the working conditions and the installation site.

Remember that the unit must be installed by a qualified and skilled technician, and in compliance with the national legislation in force in the destination country.

The installation must be done in such a way that it will be possible to carry out all routine and non-routine maintenance operations.

Before starting any work, you must carefully read the "Installation, operation and maintenance manual" of the machine and do the necessary safety checks to prevent any malfunctioning or hazards.

We give some advice below that will allow you to increase the efficiency and reliability of the unit and therefore of the system into which it is inserted.

Water characteristics

To preserve the life of the exchangers, the water is required to comply with some quality parameters and it is therefore necessary to make sure its values fall within the ranges indicated in the following table:

Total hardness	2,0 ÷ 6,0 °f
Langelier index	- 0,4 ÷ 0,4
pH	7,5 ÷ 8,5
Electrical conductivity	10 ÷ 500 µS/cm
Organic elements	-
Hydrogen carbonate (HCO₃⁻)	70 ÷ 300 ppm
Sulphates (SO₄²⁻)	< 50 ppm
Hydrogen carbonate / Sulphates (HCO₃⁻/SO₄²⁻)	> 1
Chlorides (Cl⁻)	< 50 ppm
Nitrates (NO₃⁻)	< 50 ppm
Hydrogen sulphide (H₂S)	< 0,05 ppm
Ammonia (NH₃)	< 0,05 ppm
Sulphites (SO₃), free chlorine (Cl₂)	< 1 ppm
Carbon dioxide (CO₂)	< 5 ppm
Metal cations	< 0,2 ppm
Manganese ions (Mn⁺⁺)	< 0,2 ppm
Iron ions (Fe²⁺ , Fe³⁺)	< 0,2 ppm
Iron + Manganese	< 0,4 ppm
Phosphates (PO₄³⁻)	< 2 ppm
Oxygen	< 0,1 ppm

Installation of water filters on all the hydraulic circuits is obligatory.

The supply of the most suitable filters for the unit can be requested as accessory. In this case, the filters are supplied loose and must be installed by the customer following the instructions given in the installation, operation and maintenance manual.

Glycol mixtures

With temperatures below 5°C, it is mandatory to work with water and anti-freeze mixtures, and also change the safety devices (anti-freeze, etc.), which must be carried out by qualified authorised personnel or by the manufacturer.

Liquid outlet temperature or minimum ambient temperature	°C	0	-5	-10	-15	-20	-25	-30	-35	-40
Freezing point	°C	-5	-10	-15	-20	-25	-30	-35	-40	-45
Ethylene glycol	%	6	22	30	36	41	46	50	53	56
Propylene glycol	%	15	25	33	39	44	48	51	54	57

The quantity of antifreeze should be considered as % on weight

Minimum water content in the system

For correct operation of the unit, it is necessary to ensure a buffering on the system such as to comply with the minimum operating time considering the greater between the minimum OFF time and the minimum ON time. In short, these contribute to limiting the number of times the compressors are switched on per hour and to preventing undesired deviations from the set point of the delivered water temperature.

Larger amounts of water are in any case always preferable, because they allow a smaller number of starts and switch-offs of the compressors, less wear of them and an increase in the efficiency of the system as a consequence of a reduction in the number of transients.

It should also be pointed out that, for air-water units working in heat pump mode, the minimum amount of water must consider the need of the unit to carry out defrosting. Having an adequate buffering volume will allow prevention of too high drifts of the delivered water temperature at the end of the defrost cycle.

Please check "water Volume Design" Tool for a correct estimation of minimum water content of the system in "heat pump" working mode.

The following experimental formula allows to calculate the minimum water volume of the plant.

Formula refers to unit operation in cooling mode and is also valid for heating mode if defrosting cycles are not taken in account.

$$V_{min} = \frac{P_{tot} \cdot 1000}{N} \cdot \frac{180}{\Delta T \rho C_p} + P_{tot} \cdot 0.25$$

where

V_{min} is the minimum water content of the system [l]

P_{tot} is the total cooling capacity of the machine [kW]

N: number of capacity reduction steps

ΔT : differential allowed on the water temperature. Unless otherwise specified, this value is considered to be 2.5K

ρ : density of the heat-carrying fluid. Unless otherwise specified, the density of water is considered

c_p : specific heat of the heat-carrying fluid. Unless otherwise specified, the specific heat of water is considered

Considering the use of water and grouping together some terms, the formula can be re-written as follows:

$$V_{min} = \frac{P_{tot}}{N} \cdot 17,2 + P_{tot} \cdot 0,25$$

N is equal to the number of compressors installed in the unit.

In case of installation in cold climates where the unit has to perform defrosting cycles, it is suggested to use higher water content than that calculated with previous formula; due to very high volumes needed to completely compensate the negative effect of defrost on produced water temperature, are usually accepted higher temperature deviations than typical values accepted for cooling-only unit.

Water content necessary to balance defrost cycle effect on produced water temperatures, depends on various factors:

- type of system
- compressors and circuits number
- maximum temporary acceptable temperature difference from set-point
- Quantity of defrost cycles necessary to proper functioning of the unit (depending on external and working conditions)
- compressors and circuits number

For OMICRON REV S4 units as general, indicative and not binding value, can be considered 3-5 times minimum water content necessary for cooling-only units.

Installation site

To determine the best installation site for the unit and its orientation, you should pay attention to the following points:

- compliance with the clearance spaces indicated in the official dimensional drawing of the unit must be guaranteed so as to ensure accessibility for routine and non-routine maintenance operations
- you should consider the origin of the hydraulic pipes and their diameters because these affect the radiuses of curvature and therefore the spaces needed for installing them
- you should consider the position of the cable inlet on the electrical control panel of the unit as regards the origin of the power supply
- if the installation includes several units side by side, you should consider the position and dimensions of the manifolds of the user-side exchangers and of any recovery exchangers
- if the installation includes several units side by side, you should consider that the minimum distance between units is 3 metres
- you should avoid all obstructions that can limit air circulation to the source-side exchanger or that can cause recirculation between air supply and intake
- you should consider the orientation of the unit to limit, as far as possible, exposure of the source-side exchanger to solar radiation
- if the installation area is particularly windy, the orientation and positioning of the unit must be such as to avoid air recirculation on the coils. If necessary, we advise making windbreak barriers in order to prevent malfunctioning.

Once the best position for the unit has been identified, you must check that the support slab has the following characteristics:

- its dimensions must be proportionate to those of the unit: if possible, longer and wider than the unit by at least 30 cm and 15/20cm higher than the surrounding surface
- it must be able to bear at least 4 times the operating weight of the unit
- it must allow level installation of the unit: although the unit is installed on a horizontal base, make slopes in the support surface to convey rain water or defrost water to drains, wells or in any case to places where it cannot generate an accident hazard due to ice formation. All heat pump version units are equipped with discharge manifolds for the condensed water; these can be manifolded to facilitate condensate discharge.

The units are designed and built to reduce to a minimum the level of vibration transmitted to the ground, but it is in any case advisable to use rubber or spring anti-vibration mounts, which are available as accessory and should be requested when ordering.

The anti-vibration mounts must be fixed on before positioning the unit on the ground.

In the event of installation on roofs or intermediate floors, the pipes must be isolated from the walls and ceilings.

It is advisable to avoid installation in cramped places, to prevent reverberations, reflections, resonances and acoustic interactions with elements outside the unit.

It is essential that any work done to soundproof the unit does not affect its correct installation or correct operation and, in particular, does not reduce the air flow rate to the source-side exchanger.

Installations that require the use of treated coils

If the unit has to be installed in an environment with a particularly aggressive atmosphere, coils with special treatments are available as options.

- coils with anti-corrosion treatment;

A description of the individual accessories is available in the "Description of accessories" section.

The type of coil treatment should be chosen with regard to the environment in which the unit is to be installed, through observation of other structures and machinery with exposed metal surfaces present in the destination environment.

The cross observation criterion is the most valid method of selection currently available without having to carry out preliminary tests or measurements with instruments. The identified reference environments are:

- coastal/marine
- industrial
- urban with a high housing density
- rural

Please note that in cases where different conditions co-exist, even for short periods, the choice must be suitable for preserving the exchanger in the harsher environmental conditions and not in conditions between the worst and best situation.

Particular attention must be given in cases where an environment that is not particularly aggressive becomes aggressive as a consequence of a concomitant cause, for example, the presence of a flue outlet or an extraction fan.

We strongly suggest choosing one of the treatment options if at least one of the points listed below is verified:

- there are obvious signs of corrosion of the exposed metal surfaces in the installation area
- the prevailing winds come from the sea towards the unit
- the environment is industrial with a significant concentration of pollutants
- the environment is urban with a high population density
- the environment is rural with the presence of organic discharges and effluents

In particular, for installations near the coast, the following instructions apply:

- **For units to be installed between 1 and 20 km from the coast, the use of the option "Pre-painted aluminium coil" is strongly recommended.**
- **for units to be installed within one kilometre from the coast, the use of the option "Coil treated with anti-corrosion paints" is strongly recommended.**

To protect the exchangers from corrosion and ensure optimal operation of the unit, we advise following the recommendations given in the user, installation and maintenance manual for cleaning the coils.

Aeraulic head losses and options available for the ventilating section

With the exception of units for which oversized fans are required, as standard, the units are designed considering that, at the nominal air flow rate, the fans work with null available pressure.

If there are obstacles to free air flow, you should consider the additional aeraulic head losses that will cause a reduction of the air flow rate and a consequent deterioration of performance.

The following diagrams show the trend of cooling capacity (PC), EER, total absorbed power (Pabs) and reduction of the maximum external air temperature in chiller operating mode, depending on the aeraulic head losses that the fans will have to overcome.

AC fans (Ø 800)

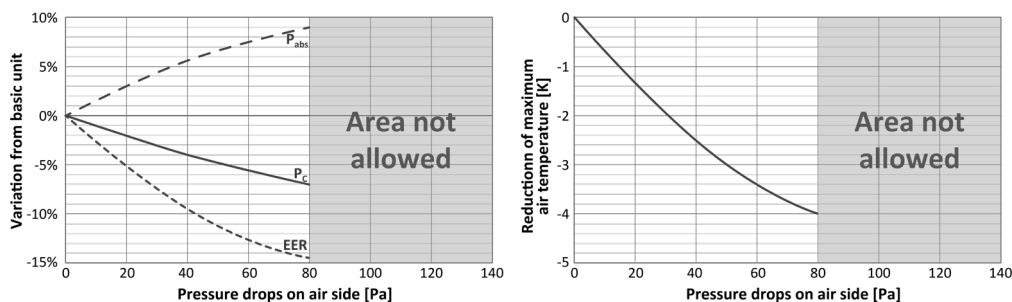

EC fans (Ø 800)

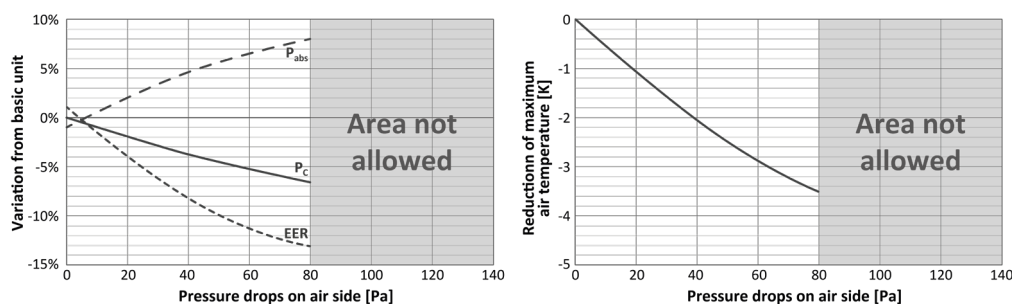

Oversize EC fans (Ø 800)

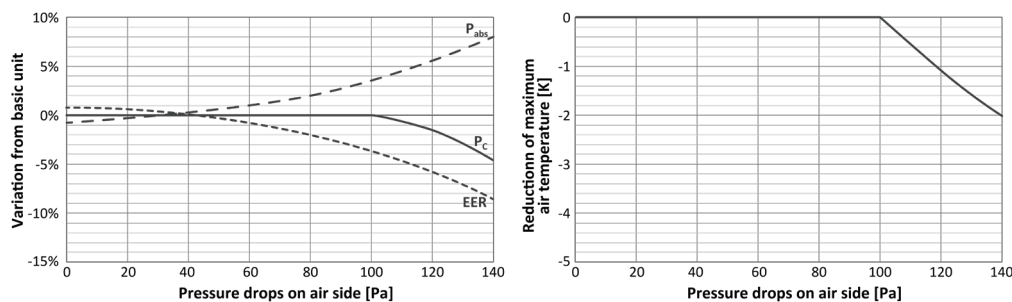

The indicated values are for the standard machine, without accessories, with AC fans and in any case in the absence of air recirculation.

Example: supposing you expect there to be obstacles that will generate an estimated aeraulic head loss of 60Pa. In this case, there are 3 possibilities:

- use the unit with standard AC fans: compared to ideal conditions, the output power will be reduced by about 5.5%, the total absorbed power will increase by about 7.5%, the EER will be reduced by about 12.5% and the maximum allowed external air temperature for operation at 100% will be reduced by about 3.4K compared to the nominal limit
- use the unit with EC fans: compared to the unit with AC fans working in ideal conditions, the output power will be reduced by about 5%, the total absorbed power will increase by about 6.5%, the EER will be reduced by about 11.5% and the maximum allowed external air temperature for operation at 100% will be reduced by about 2.8K compared to the nominal limit
- use the unit with oversize EC fans: compared to the unit with AC fans working in ideal conditions, the output power of the unit will be unchanged, the total absorbed power will increase by about 1%, the EER will be reduced by about 2% and the maximum external air temperature will remain the one shown in the diagram of the operating limits.

Installation site

To determine the best installation site for the unit and its orientation, you should pay attention to the following points:

- compliance with the clearance spaces indicated in the official dimensional drawing of the unit must be guaranteed so as to ensure accessibility for routine and non-routine maintenance operations
- compliance with the respect spaces indicated in the installation, use and maintenance manual must be guaranteed, in relation to units with highly flammable A3 refrigerant
- you should consider the origin of the hydraulic pipes and their diameters because these affect the radiuses of curvature and therefore the spaces needed for installing them
- you should consider the position of the cable inlet on the electrical control panel of the unit as regards the origin of the power supply
- if the installation includes several units side by side, you should consider the position and dimensions of the manifolds of the user-side exchangers and of any recovery exchangers
- if the installation includes several units side by side, you should consider that the minimum distance between units is 3 metres
- you should avoid all obstructions that can limit air circulation to the source-side exchanger or that can cause recirculation between air supply and intake
- you should consider the orientation of the unit to limit, as far as possible, exposure of the source-side exchanger to solar radiation
- if the installation area is particularly windy, the orientation and positioning of the unit must be such as to avoid air recirculation on the coils. If necessary, we advise making windbreak barriers in order to prevent malfunctioning.

Once the best position for the unit has been identified, you must check that the support slab has the following characteristics:

- its dimensions must be proportionate to those of the unit: if possible, longer and wider than the unit by at least 30 cm and 15/20cm higher than the surrounding surface
- it must be able to bear at least 4 times the operating weight of the unit
- it must allow level installation of the unit: although the unit is installed on a horizontal base, make slopes in the support surface to convey rain water or defrost water to drains, wells or in any case to places where it cannot generate an accident hazard due to ice formation. All heat pump version units are equipped with discharge manifolds for the condensed water; these can be manifolded to facilitate condensate discharge.

The units are designed and built to reduce to a minimum the level of vibration transmitted to the ground, but it is in any case advisable to use rubber or spring anti-vibration mounts, which are available as accessory and should be requested when ordering.

The anti-vibration mounts must be fixed on before positioning the unit on the ground.

In the event of installation on roofs or intermediate floors, the pipes must be isolated from the walls and ceilings.

It is advisable to avoid installation in cramped places, to prevent reverberations, reflections, resonances and acoustic interactions with elements outside the unit.

It is essential that any work done to soundproof the unit does not affect its correct installation or correct operation and, in particular, does not reduce the air flow rate to the source-side exchanger.

Installation types

Generally, an air conditioning unit is installed in rooms that are normally occupied by people, in general-purpose rooms or in dedicated technical room such as **machinery rooms**. Another possible option is unit installation **outdoors, in the open air**. Also, several access categories are defined for each installation. The type of installation and access category determine the maximum permitted refrigerant charge for the installation, depending on the type of refrigerant in use.

This guide specifically addresses:

- hydronic climate control units; chillers and heat pumps for **Class III outdoor** installations (open space installations). In the case of Class III installation in open field where all the standard and manufacturer's standards relating to the installation of the unit are respected, there is no restriction on the amount of charge of the installed unit if the access category and type "c" (authorized access).

For further information regarding installation classes, access categories and the charge limit, consult the Standard EN378-1.

Compliance with class III is also linked to the fact that the hydraulic system that carries the fluid that is heated or cooled by the unit to the various users complies with the requirements defined by EN 378-1 in section 5.5. 2 to avoid the possibility of a leak of refrigerant flowing into occupied rooms. See the section "Hydraulic Connections" for a description of the various solutions that are applicable to our types of unit.

Failure to comply with the provisions regarding the hydraulic system will result in the installation being downgraded to Class I or Class II, in which case the refrigerant charge limits are lower than in Class III (Ref. EN 378-1, Annex C).

In general, **the person in charge of the installation** (generally the designer), must ensure compliance with the standard requirements by carrying out a risk assessment mainly according to the manufacturer's instructions and standards, such as EN378-1, EN378-3, or IEC 60335-2-40:2018 when applicable. All other considerations aside, the installation must also conform with the applicable local or national regulations.

The installation technician must install the units as defined in the project. Before starting to install the units, the installation technician must carry out his/her own assessment, within the limits of his/her technical qualifications and issue the Declaration of Conformity once the work is complete.

The installation supervisor is responsible for guaranteeing the conformity of the system.

We strongly recommend that a consultant/qualified third-party body be involved in the installation conformity assessment process, based on the type and quantity of refrigerant used.

In order to ensure complete safety of the application, it is fundamentally important to respect the type of installation the unit has been designed for.

Where more stringent than the provisions set out in the applicable regulations, the installation shall conform to the local/national regulations.

Definitions

For reasons of clarity, it has been deemed helpful to introduce a series of additional definitions; This section simply lists the additional definitions that have been introduced, which are important when conducting the risk assessment. The technical handbook contains further information about the various components used.

- **User terminal side heat exchanger/Desuperheater**

This type of heat exchanger is used to transfer heat from or to the hydraulic circuit vector fluid and, hence, heat or cool the climate controlled environments. The desuperheater is a dedicated heat exchanger used to heat a specific hydraulic circuit. Such units normally consist of a brazed plate heat exchanger. Other types of heat exchanger may be used.

- **Source-side heat exchanger**

This type of heat exchanger is used to transfer the heat extracted from/yielded to the user terminal side hydraulic circuit vector fluid towards the outdoor air when cooling/heating the climate controlled environments. Usually, finned or micro-channel coils. Other types of heat exchanger may be used. For example, in the case of water dissipation type source units, either brazed plate or tube bundle heat exchangers may be used.

- **Refrigerant leaks**

Refrigerant gas escaping from the container/object used to store it; in the case of Chillers or Heat Pumps, the gas will escape from the refrigerating circuit or one of its components. As the refrigerants in question are flammable, under certain circumstances gas leaks may result in the formation of flammable or explosive atmospheres. Such instances include, but are not limited to:

- refrigerant gas leaks from the unit refrigerating circuit due to one of its components malfunctioning or being damaged;

- refrigerant gas leaks caused by the unit safety valve being activated;

- refrigerant gas leaks caused by the unit heat exchanger or finned battery being damaged;

- accidental release of refrigerant gas from the refrigerating circuit, or cylinders used to store the gas, during maintenance activities.

- **Installation Class (Ref EN378-1):**

The Standard defines for Installation Classes.

- **Access Category (Ref EN378-1):**

a = public; **b** = restricted or supervised; **c** = controlled or authorised.

- **Charge Limit (Ref EN378-1):**

The Standard defines maximum refrigerant charge limits, depending on the installation class, access category and type of refrigerant in use.

- **LFL (Ref EN378-1):**

The lowest percentage of a substance in air that can lead to flame propagation.

- **The safety class or category of a refrigerant fluid (EN 378-1):**

categorization of a substance as flammable or non-flammable, toxic or non-toxic.

- **#B#ATEX Zone 2 (Ref. EN 60079-10-1 and IOM) and Safety Zone (Ref IOM):**

see section: "Class III hydronic unit installations in open air environments".

- **Ignition Sources (Ref EN378-2):**

External sources that could lead to flame propagation in a combustible atmosphere.

- **Installation:**

Installation is defined as the unit positioned and installed correctly and operational as set out in the IOM manual. This definition **does not** include the activities involved in preparing the installation (construction of the hydraulic and electrical systems, realising the infrastructure, etc.) In addition to the reference standards, further information may be found in the Appendix to this document.

- **Electrical control panel**

Electrical control panel QE. For further details, see the dedicated chapter.

- **Technical compartment**

Technical compartment VT. The refrigeration circuit is enclosed in a compartment that contains an ATEX certified leak sensor and an ATEX certified extraction fan.

Class III hydronic unit installations in open air environments

In order for the outdoor installation of units containing flammable and non-toxic refrigerant to be considered class III, the following are some of the additional assessments that the **responsible for the installation (customer, installer, consultant, ...)** must do to ensure that any gas leak does not generate dangerous situations [note1] .

1. The units must be positioned so as to prevent any refrigerant leaks from reaching the enclosed spaces, creating temporarily flammable zones or harming persons or property. Leaks must be prevented from flowing into manholes and storm drains and directly onto personnel and must not be directed towards air vents designated to serve enclosed spaces. Leaks must also be kept away from fresh air intakes, doors or similar openings, as well as ignition sources as defined by the Standard EN378-1. here is an obligation to convey the discharge of the safety valves via piping compliant with national and/or European directives, the area of which the refrigerant escapes must comply with the same requirements described above valid in the event of a leak.



The installation, use and maintenance manual and the dedicated documentation offer a detailed explanation of how the drainage channel must be created and calculated and any identification requirements required, but it must be remembered that the responsibility falls in any case on the person in charge of the installation.



Standard EN13136:2019 should be referenced for the calculation and sizing of the safety valve exhaust.



The conveying must be done with a pipe whose diameter must be at least that of the valve outlet, and the weight of the pipe must not be borne by the valve. When positioning the safety valve discharge line, it should be taken into account that the Atex Zone 2 (note2) generated by the emissions from a safety valve differs from the Atex Zone 2 defined for the unit.



Zone 2 forming from the emissions of a safety valve may extend horizontally up to 10 metres and vertically up to 11 metres.

The assessment of the risk areas is the responsibility of the installation supervisor. Exhausted material must not be conveyed close to ignition sources, as defined in standard EN378-2.

Where the existing local regulations are more stringent, these should be taken as reference.



Always use the appropriate type of fire extinguishers for the refrigerant in use in proximity to the unit.

Notes

1 For further details and a complete list of requirements, refer to EN378-3: Paragraph 4.2, Paragraph 6.2.14 and Annex K. Paragraphs 4.3, 5.1 and 5.14 in the case of leaks as indicated in point 2 below (leaks underground or inside cavities). In addition, national directives, if any, must always be observed.

2 Zone 2 according to the Atex directive is an area in which the formation of an explosive atmosphere of air and flammable substances in the form of gas, vapor or mist is not likely during normal activities and, if it occurs, it is only of short duration.

2. If the refrigerant leak can stagnate, for example, underground or inside cavities, the installation must comply with the requirements for gas detection and ventilation of engine rooms and where applicable, also compliant with the requirements for ignition sources as defined by EN378-2. Reference to the section on machinery rooms in standard EN 378-3 should be made in this case.

3. Where the unit is installed in the open air, but under a shelter, ventilation must be guaranteed.

4. If the unit installed is inside a room, where at least one of the longest walls is open to outside air for at least 80% of the wall area (or equivalent if more of a wall must be outdoors) and covered by slats/grids with at least 75% free area, is considered as an outdoor installation.

5. When conducting the risk assessment, the installation supervisor must also take the following indications into account.

- In the event of leaks, the unit gives rise to an Atex "zone 2" classified environment around the machine.
- Based on the above, the designation of a safety "zone/area" around the machine is deemed to be appropriate.

In a "zone 2":

- installation of equipment unsuitable for use in such potentially explosive zones must be avoided (the minimum equipment requirements are: 3G IIB T4);
- naked flames, sparks and hot work must be avoided;
- sources of ignition that are due to processes must be avoided, since they are likely to give way to remote ignition (ionizing and non-ionizing radiation);
- direct and indirect effects of electrocution must be avoided;
- electrostatic charges must be avoided;
- interference must be avoided with elements that may be hazardous, including sewage systems, openings towards stone retaining walls, underground spaces, power lines, flammable material warehouses, railways, motorways, etc.

In the safety "zone/area", storage of refrigerant bags must be avoided in spaces such as sewage systems, manholes, water traps, openings towards stone retaining walls, underground spaces, etc.

Refer to national or local regulations on this issue, where applicable.

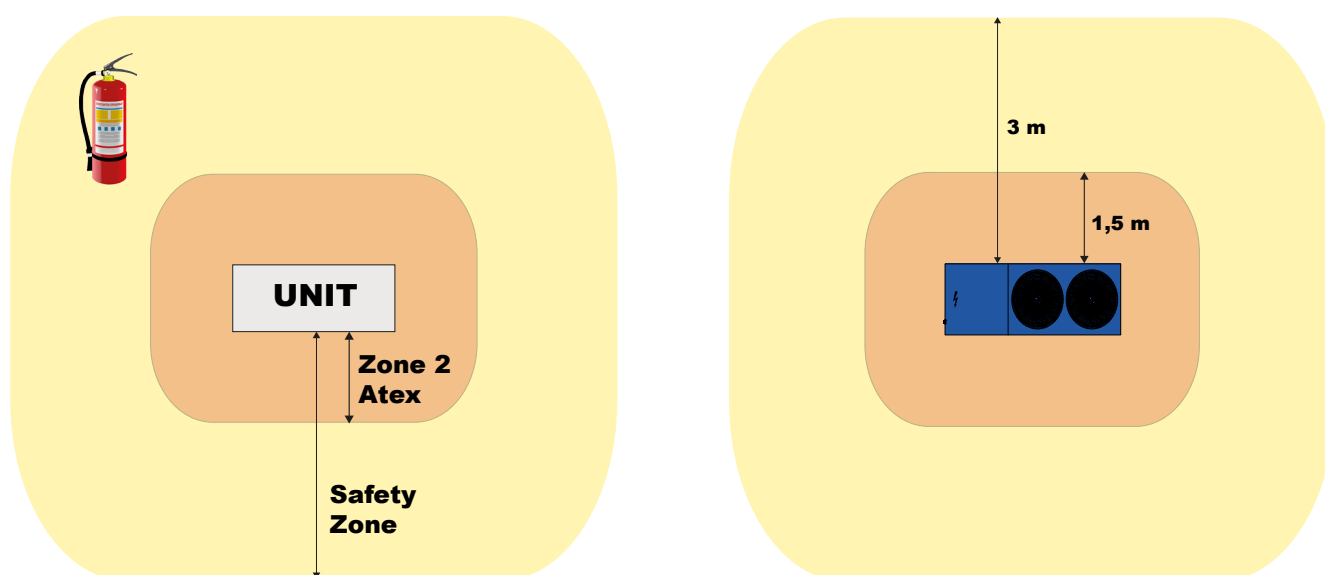

For further details, please refer to the "Instruction manual for operation and maintenance".

For further details, please refer to the "Instruction manual for operation and maintenance".

6. Confirm that noise barriers or other protection systems, if any, cannot create areas where leaks can stagnate.
7. Also take into account the possible leaks that can occur on parts of the circuit that are normally closed, for example from panels that can be removed or from doors that can be left open during maintenance activities.



To guarantee the correct functioning of the unit, it is mandatory to guarantee the clearances specified in the dimensional drawings. Always check the Atex Zone 2 and the respect/safety zone and any installation limitations in the Installation, Use and Maintenance manual.

Access restriction is part of correct installation to eliminate residual risks during normal operation.

Hydraulic Connections

The chillers and heat pumps are normally used to heat and/or cool a closed water circuit connected to system terminals such as fan coils, etc., which are usually located in occupied spaces. The plumbing then connects the building utilities with the refrigeration machine, so in Class III installations, for compliance to occur, the installer must take extra precautions to prevent a refrigerant leak into the hydraulic circuit through the heat exchanger then flows inside occupied rooms and or generates a flammable mixture, as required by EN 378-1 and EN378-3.

- The hydraulic system must be protected against accidental damage.
- There must be a vent system using suitably calibrated safety valves, so that any refrigerant is discharged outdoors in compliance with all the prescriptions relating to refrigerant discharge already indicated in the section "Class III outdoor installations for hydronic units" . The calibration setting must take into account the operating pressure of the hydraulic circuit, the altitude and the type of refrigerant fluid. All safety requirements applicable to sources of leakage from the unit also apply to the hydraulic system.
- Hydraulic components, accumulator tanks and any other open type components or elements that could release refrigerant as a consequence of a leak from the heat exchanger must be installed outdoors. The same safety precautions must be implemented as for any other potential source of leaks from the unit. If it is not possible to install such elements outdoors, they must be replaced with equivalent, watertight components.
- If there is a hydraulic decoupling device installed between the primary and secondary circuits, assess whether it is sufficient to implement the above precautions to the primary circuit only.



In the event that the installation solutions defined in the previous points are not possible but these devices are confined within a machine room, it is the duty of the installation manager to carry out a flammability assessment and classification of the danger area for the room technical as required by the EN378-3 standard".

The precautions implemented on the desuperheater hydraulic circuit must be the same as those adopted for the main heat exchanger.

Guidelines for the risk assessment

The purpose of this section is to provide all elements specific to the Swegon Operations S.r.L. production units. with A2, A2L and A3 refrigerants to allow the installation manager to carry out the risk assessment associated with the installation and, consequently, to determine the prevention, protection and management measures to be adopted to pursue the following safety objectives:

- minimise the causes of fires or explosions;
- guarantee the stability of the supporting structures for a predetermined period of time;
- limit the instance and spread of fires inside the building;
- limit the spread of fires to adjacent buildings;
- limit the effects of explosions;
- ensure that occupants are able to leave the building unassisted or receive assistance in other ways;
- ensure that emergency services are able to intervene in conditions of safety.

The installation supervisor is responsible for compiling the installation risk assessment.

The information is in accordance with the European standard EN378 with particular reference to the effects on the environment and on the safety of people and things in the context linked to the installation of Swegon Operations S.r.L. production units. containing refrigerants classified A2L, A2 and A3.

The Technical Handbook includes information regarding the manufacturing specifications, technical and performance data, available accessories and all the other elements necessary for a full understanding of the units.

The Installation, Operating and Maintenance manual contains the information necessary to install, operate and service the units.

The technical data label, the additional labels, the wiring diagram, the refrigeration diagram, the hydraulic diagram, the dimensional diagram, the instructions concerning handling and the accompanying documentation show technical data, dimensions, clearances, data and electrical characteristics and hydraulics, utility connections, handling information and much more.

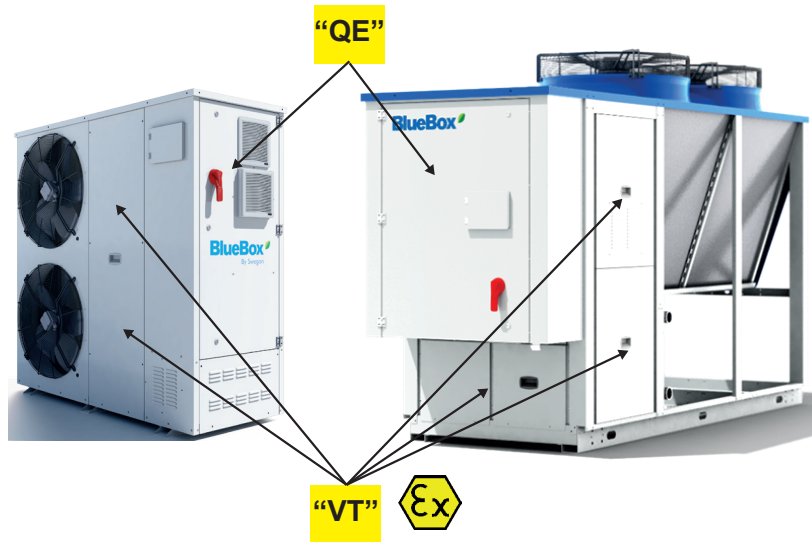

Thus, when defining the project and conducting the risk assessment, it is necessary to take various situations into account, including:

- how to properly convey any gas exhausted by the safety valves and how any leakage from the coils or any exhaust from the technical compartment (VT) may be made to flow to the safe area, as described above;
- a check that any leak in the "VT" is sensed by the refrigerant sensor at the time when the concentration exceeds 10% the LFL. The three-phase power supply is cut out and the unit consequently switches off. The extraction fan in the "VT" is started so that the air-refrigerant mix is expelled to the outside. The fans in the electric panel (QE) are switched on, if they are not already. The rest of the unit is off and the safety device chain only is active. The unit reports the leak condition by means of a light indicator and through a potential-free contact. After the leak is cleared safely, the sensor requires resetting, which is done by cutting out power to the sensor. When the sensor is energised again, a "warm-up" procedure gets started. A reading test is recommended after a leak has been identified;
- where a leak external to the "VT", originating from the unit batteries, is not detected by the refrigerant sensor but is prevented from entering the "QE" due to it being isolated. If the leak were to reach the axial fans, the speed of the air and effect of dilution would cause it to be dispersed. If the leaking gas manages to access the "VT", the previous case applies;
- if the sensor experiences a malfunction or power to it is cut out, but the unit is energised, the system basically starts the same actions listed for any leakage detected inside the "VT". Dedicated warning lights/messages are activated in this case, which are different from those relating to a leak;
- a blackout of the three-phase line switches the entire unit off, safety device chain included;
- a short blackout does not normally require an inspection by a qualified technician before the power line is restored;
- if the power failure lasts for a long time, we strongly recommend that a skilled technician be asked to test the unit for leaks on site: this evaluation must be part of the risk analysis;
- in any case, as soon as power is restored, the sensor runs the warm-up procedure, at the end of which an OK signal is output, where no leaks are identified, to restore power to the rest of the unit.

Despite the requirements adopted in units containing A3 flammable refrigerants, and although some components may be ATEX compliant, Swegon Operations units containing A3 **refrigerants are not suitable** to be installed in explosive environments as required by the ATEX directive.

Applicable standards and regulations and reference documents

The main regulatory framework is given by the complete EN378, while for a complete regulatory framework it is useful to refer to the final part of the Swegon guides on flammable refrigerants.

EN378: refrigerating systems and heat pumps

- EN378-1: Basic requirements, definitions, classification and selection criteria.
- EN378-2: Design, construction, testing, marking and documentation.
- EN378-3: Installation site and personal protection.
- EN378-4: Operation, maintenance, repair and recovery.

It is also useful to include a list of the principal reference documents that should be adopted when drawing up the risk assessment (complete with the respective abbreviations).

The following documents constitute an integral part of the machine documentation. The documents are indicated by the abbreviations used to refer to them in the risk assessment.

- **IOM**: Installation, Operating and Maintenance manual This is the document where it is possible to find information relating to product safety and the correct way of operating, information on installation, Atex zone 2, safety zone and on the specific prescriptions relating to flammable refrigerant, start-up and maintenance of the units, as well as information on the competent personnel who may operate. This document is essential for personnel assigned install and operate the unit.
- **DimDiag**: The dimensions diagram illustrates the physical dimensions of the unit and the respective operating spaces.
- **ELDiag**: The electrical circuit diagram includes all the information regarding the unit electrical connections and the external connections to the unit.
- **Declaration of Conformity**: this document indicates the various EEC Directives and Regulations the unit conforms to.
- **PDoc**: an assessment conducted by the installation technician or other personnel responsible for the installation site.
- **TH**: Technical handbook or catalogue This document covers the technical and electrical data, the hydronic units and pumps; it includes the unit operating limits and various other information. This document is essential when designing a unit installation, especially in the case of projects that include units containing flammable refrigerants.

It is important to recall that, when installing units containing A3 classified refrigerants, it may be necessary to obtain permission from the relevant Authority.

Installation risk assessment

Transport, positioning and storage are not included in the scope of the installation risk assessment. The section "Reception, handling and storage of units containing flammable refrigerants" of this document provides information of performing these phases correctly and as safely as possible.

The residual risks described in the Installation, Operating and Maintenance manual must also be taken into account when conducting the risk assessment.

The following table contains a series of indications designed to assist the installation supervisor in conducting the risk assessment, and in minimising the risks themselves.

How to minimise fire risks in the installation.

Installing the unit

The unit must be installed in a workmanlike manner, by a certified and titled company, respecting the manufacturer's specific instructions given in the IUM manual and adopting all the necessary fire prevention, protection and management measures.

The unit must be installed outdoors in such a way as to prevent any refrigerant leaks from reaching the enclosed spaces, creating temporarily flammable zones or harming persons or property. Suitable fire extinguishing systems, corresponding to the type of refrigerant in use, must be installed in the vicinity of the unit.

Ignition sources

There **must not** be any ignition sources present **inside** the Atex Zone 2 of the unit, if such a zone is defined for the unit/installation being assessed. If no Atex Zone 2 is defined, the installation supervisor is responsible for assessing the presence/vicinity or otherwise of ignition sources, depending on the type of unit, the refrigerant in use, the installation, etc.

Refrigerant stagnation areas

There **must not** be any refrigerant stagnation areas, where refrigerant could be trapped in the event of a leak, present **inside** the unit safety zone.

Refrigerant leaks

From the unit refrigerating circuit.

The unit refrigerating circuit, which is housed inside the technical compartment, is fitted with a refrigerant detector that is tripped if the concentration exceeds 10% of the LFL. The technical compartment is purged by expelling the refrigerant, which mainly builds up under the finned coils. The refrigerant is expelled by means of Atex fans.

The Atex Zone 2 and Safety zone must be respected.

From the source side heat exchanger.

The leak is external to the unit and, if it does not enter the technical compartment, the unit continues to operate. In this case, the electrical components in the technical compartment are not affected by the leak. The leak cannot reach the electrical panel if the installations specifications have been respected. It should be taken into account the fact that, if the installation is located nearby marine environments or in the presence of aggressive atmospheres, and the coils are not treated accordingly, there is a greater chance of leaks. **If defined, the Atex Zone 2 and Safety zone must be respected.**

From the user terminal side heat exchanger.

The refrigerant leak flows from the refrigerating circuit towards the hydraulic system via the heat exchanger. The leak is not detected and the unit continues to operate. It **is obligatory** to respect the provisions relating to the hydraulic system. If the installation includes vents or de-aerators, the risk assessment may also involve defining specific Atex 2 zones.

From the safety valve vent.

Correct discharge of the refrigerant vented by the safety valves plays a **fundamental** role in minimising fire risks. Such leaks must be routed as set out in the IOM manual, taking into account the fact that the outlet of the discharge line gives rise to an additional **Atex 2 Zone, which must also be respected**

External to the unit but not deriving from it

The unit is not suitable for use in flammable atmospheres. The leak must be detected as set out in the applicable standards and the unit made safe; for example, the unit must be completely isolated from its electrical power supply until the fault has been corrected and the flammable atmosphere eliminated.

#B#Main procedures that should be adopted:

- The use of either forced or natural ventilation helps to dilute the refrigerant and dissipate it in the surrounding air more rapidly.
- The electrical power supply to all devices not designed to be operated in flammable atmospheres should be interrupted if they are affected by the leak.
- All potential ignition sources that may be affected by the leak must be removed, if present.
- Avoid creating areas where build ups of refrigerant may accumulate, resulting in localised zones where flammable atmospheres may be present.
- Refrigerant must be prevented from reaching closed or occupied spaces, fresh air intakes, windows and other openings.
- The refrigerant Propane-R290 is heavier than air, which means that it tends to build up close to ground level.
- Additional safety procedures may be implemented, depending on the specifics of the individual installation site.

Unit refrigerant detector fault

When a detector fault is identified, the unit enters safe mode, disconnecting all the electrical components not designed to be operated in flammable atmospheres from their power supply. The unit stops working. Only the technical compartment extractor fans, the electrical panel cooling fans and the leak sensor remain energised. This is **not** a leak condition, but it is necessary to check the refrigerant detector and restore correct operation as soon as possible.

Generic unit fault

A generic fault does not give rise to a refrigerant leak. A fault that does give rise to a leak falls with the description provided above.

Fault on the extractor fan

The unit handles a potential refrigerant leak in safe mode, as described above, disconnecting all the electrical components not designed to be operated in flammable atmospheres from their power supply. Refrigerant leaks from the technical compartment are slower, but spread to all parts of the compartment, rather than being concentrated mainly under the finned coil. **If defined, the Atex Zone 2 and Safety zone must be respected.**

Electrical power supply absent

Since it is not energised, the unit is safe, meaning that any leaks that may occur in this condition cannot come into contact with potential ignition sources. In this condition, the refrigerant sensor and the Atex extractor fan are deactivated. When the unit is switched on again, check there is no refrigerant present before supplying the rest of the unit. **If defined, the Atex Zone 2 and Safety zone must be respected.**

Presence of flammable material

The presence of flammable material is prohibited within the Safety zone. Check the refrigerant safety data sheet to assess which other substances may represent a hazard if they come into contact with the refrigerant.

Suggestions for conducting and drawing up the risk assessment

This section contains an example that highlights the possible requirements to be complied with and the minimum information that must be filled in by the installation manager when drafting the risk assessment for a typical installation. The abbreviations describe the contents to be inserted in the various columns.

- **App.** = applicability of the provision (complete the empty fields according to the type of installation).
- **A** = the provision is applicable. It is possible to indicate a limit, a threshold, a distance, etc. that must be respected. If no indications are present, the provision is applicable but it is not necessary to respect any limits. For example, if an Atex zone 2 is defined, there is a minimum distance to respect and this is the limit to indicate, while in the case of the presence of fire extinguishers, it is sufficient that the fire extinguishers are present, therefore there is no limit to indicate. **Attention:** where they are more stringent, always refer to the local regulations for clarification regarding the applicability of the provisions. Since they are applicable for this type of installation, certain provisions are already indicated as applicable in the following example.
- **Conf.** = prescription compliance. Indicate whether the prescription is complied with or not. All non-conformities must be described in detail in the list at the bottom of the table, in correspondence with the number of the note specified when assigning responsibility for the non-conformity.
- **Doc.** = prescription reference document (fill in the empty fields in accordance with the assessment specifying any additional documents).
- **Note** = indicate a note reference, to be included in the footer list with explanation of the item, if necessary. It is also possible to insert a brief description in the case of applicability and conformity.

The risk assessment must include the following fields:

- Name of the installation site.
- Town/City.
- Address.
- Proprietor.
- Intended use.
- Person responsible for the risk assessment.
- Date.

So the risk assessment could be drafted as follows and contain, for example, the following information:

Unit model:					
Serial No.: SB.....	App.	Doc.	Conf.		Notes
			Yes	No	
Type of Refrigerant:					
Quantity of refrigerant (kg):					
Circuit 1 =					
Circuit 2 =					
Circuit 3 =					
Circuit 4 =					
Classification (A2L, A3, Other):					
Installation specifications.					
Operative clearance spaces - single unit.	A	SchDI			
Operative clearance spaces - adjacent units.	A	IOM			
ATEX 2 Zone Refrigerant leak - refrigerating circuit.	A	IOM			
ATEX 2 Zone Safety valves discharge: horizontal.	A	IOM			
ATEX 2 Zone Safety valves discharge: vertical.	A	IOM			
Safety zone.	A	IOM			
Type of installation (indicate class and access category).	A	IOM			
Charge limit (indicate charge limit value).	A	EN378-1			
Access to the area around the unit is restricted to qualified personnel only.	A	IOM			
Fire extinguishers suitable for use on Propane in the vicinity of the unit.	A	IOM			
		EN378-3			
Ventilation guaranteed.	A	IOM			
		EN378-3			
It is forbidden to smoke or carry out any activities that involve introducing ignition sources into the ATEX 2 zone.	A	IOM			
		EN378-3			
Presence of one or more emergency circuit breakers for interrupting the power supply to the unit.		EN378-3			
Presence of refrigerant detectors in the installation (indicate trip setting level and area covered).					
Refrigerant leaks must not occur in the vicinity of ignition sources, fresh air inlets, closed and/or occupied spaces, doors or similar openings, manholes, storm drains or any other opening that could contain the refrigerant.		IOM			
		EN378-3			
The installation site conforms to the fire prevention directives (indicate reference document).					
The escape routes must conform to the requirements of the fire prevention directive (indicate reference document).					
Other, depending on the characteristics of the installation.					
Unit safety valves.					
Safety valve discharge line.	A	Pdoc			

Unit model:	App.	Doc.	Conf.		Notes
Serial No.: SB.....			Yes	No	
i. Manufactured according to IUM, dimensional scheme and national directives.	A	IOM			
ii. Inner diameter not less than the diameter of the safety valve outlet.	A	SchDI			
iii. The weight of the pipe must not weigh on the safety valve.	A	IOM			
iv. Sealed from the surrounding environment.	A	IOM			
	A	EN378			
v. There must be no sources of ignition inside the exhaust pipe.	A	IOM			
	A	EN378			
vi. Calculation and sizing of the drain.	A	EN13136:			
	A	2013			
vii. Escaping refrigerant must not be in the vicinity of sources of ignition, fresh air intakes, confined and/or occupied spaces, doors or similar openings of drains, manhole covers and any other openings which may contain refrigerant.	A	IOM			
		EN378-3			
viii. The drain must not cause damage to people or things.	A	IOM			
		EN378-3			
Unit equipment.					
Installing accessories.					
• Accessories suitable for use in flammable atmospheres.		Pdoc			
• Accessories not suitable for use in flammable atmospheres.		Pdoc			
• Other, according to unit configuration.					
Unit equipped with refrigerant leak sensor.	A	IOM			
• Read/run check at start up.	A	IOM			
• Periodic reading/operation check.	A	IOM			"e.g.(2)"
Unit equipped with ATEX cable glands.	A	IOM			
• Start-up tightening check.	A	IOM			
• Periodic tightening check.	A	IOM			

Unit model:	App.	Doc.	Conf.		Notes
Serial No.: SB.....			Yes	No	
Hydraulic circuits 1					
Hydraulic circuit in conformity with EN378-32.	A	IOM EN378-3			
• It is compulsory to use systems in the hydraulic system capable of eliminating the presence of refrigerant gas in the event of a leak (vents, safety valves, degassers, other). These systems must be outside or safely conveyed outside according to requirements similar to points iv, v, vii and viii of the item "safety valve discharge".	A	IOM EN378-3			
• The conveying pipe, if present, must be correctly sized and made according to the indications of the reference standard.	A	Pdoc			
• Open-type components connected to the plumbing system must be installed outdoors or replaced by sealed equivalents.	A	IOM EN378-3			
• Comply with the Atex zone 2 of the vents or safety valves of the hydraulic system (indicate the Atex Zone 2 limit).	A	Pdoc			
• Respect zone 2 Atex open components of the hydraulic system installed outdoors (indicate Zone 2 Atex limit).	A	Pdoc			
• Comply with Atex Zone 2 due to loss of refrigerant from the hydraulic system (indicate Atex Zone 2 limit).	A	Pdoc			
• Other, according to the characteristics of the hydraulic system.	A	Pdoc			
Electrical connections.					
The electrical connections must be realised in a professional manner by operators who are qualified to design and install electrical systems, in accordance with applicable international and national standards.	A	IOM			
The system must be connected to earth.	A	IOM SchEL			
Power supply voltage and frequency corresponding to the electrical data specified for the unit (indicate nominal values).	A	IOM			
	A	SchEL			
The weight of the cables must not be borne by the electrical connection system.	A	IOM			
The cross-section of the cable and the line protection devices must correspond to those indicated in the wiring diagram.	A	IOM			
	A	SchEL			
The passage of any cable from the outside to the inside of the electrical panel must only take place using cable glands suitable for the diameter of the cable; any free cable glands available in the electrical panel are suitable. Do not insert more than one cable per gland; do not use sheaths inside the cable glands.	A	IOM			
The electrical panel must not be drilled, modified or tampered with in any way; do not leave any apertures.	A	IOM			
Additional provisions regarding the installation site					
...					
Other					
...					

DIMENSIONAL DIAGRAMS

OMICRON ZERO S4 5.2-6.2-7.2

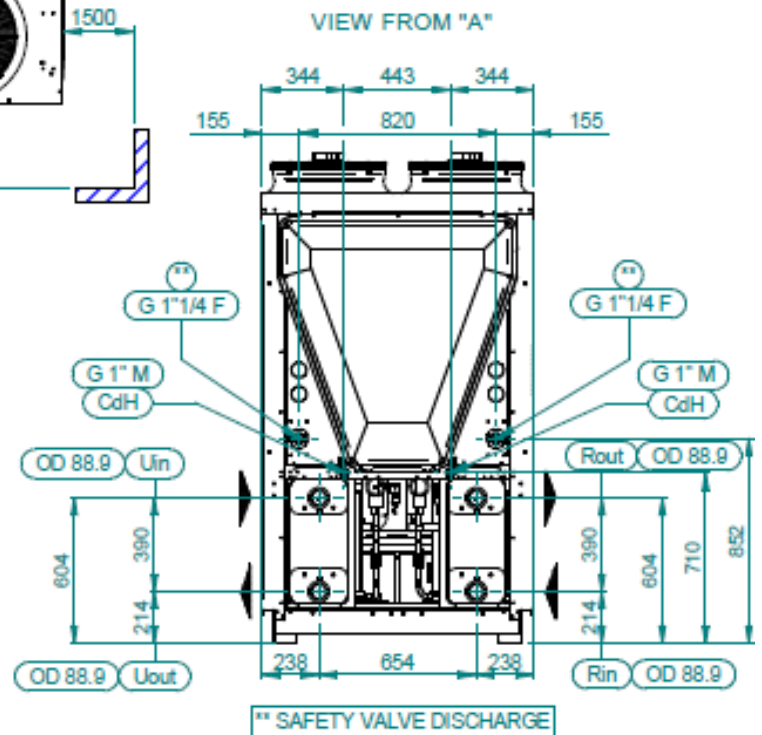
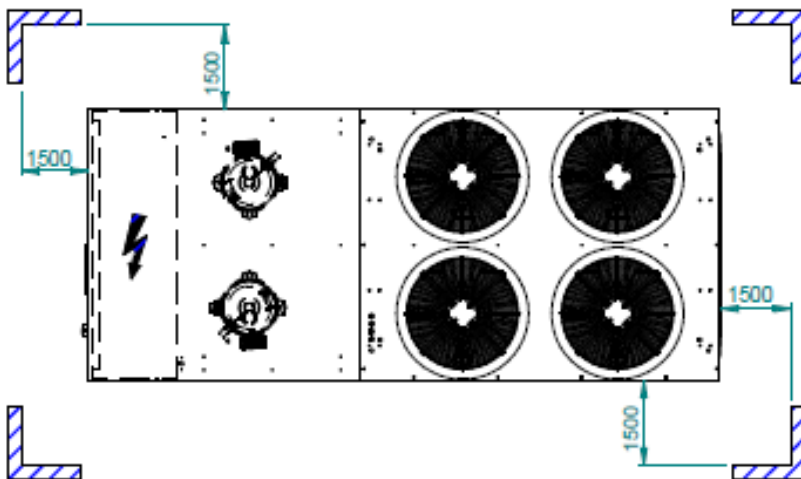
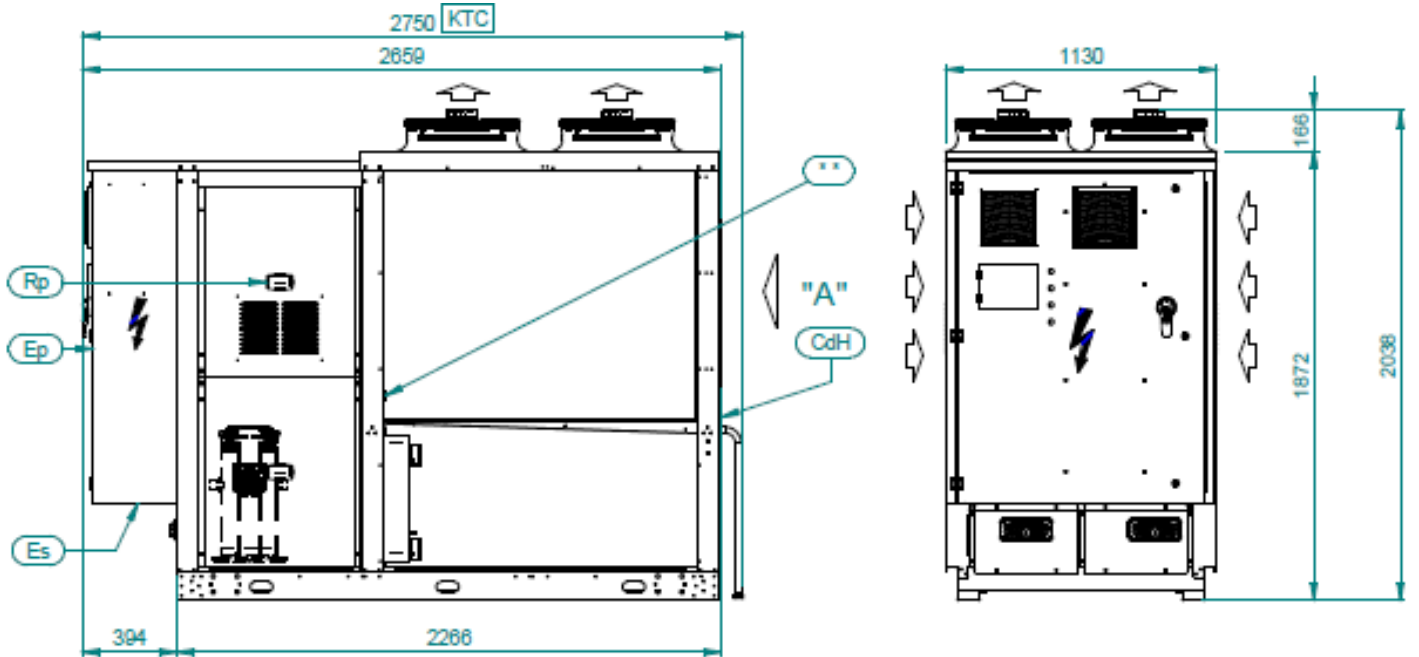

□ SAP CODE OF OPTIONS

Note: These drawings are not contractually binding. For the installation design, refer to the specific dimensional drawing available on request.

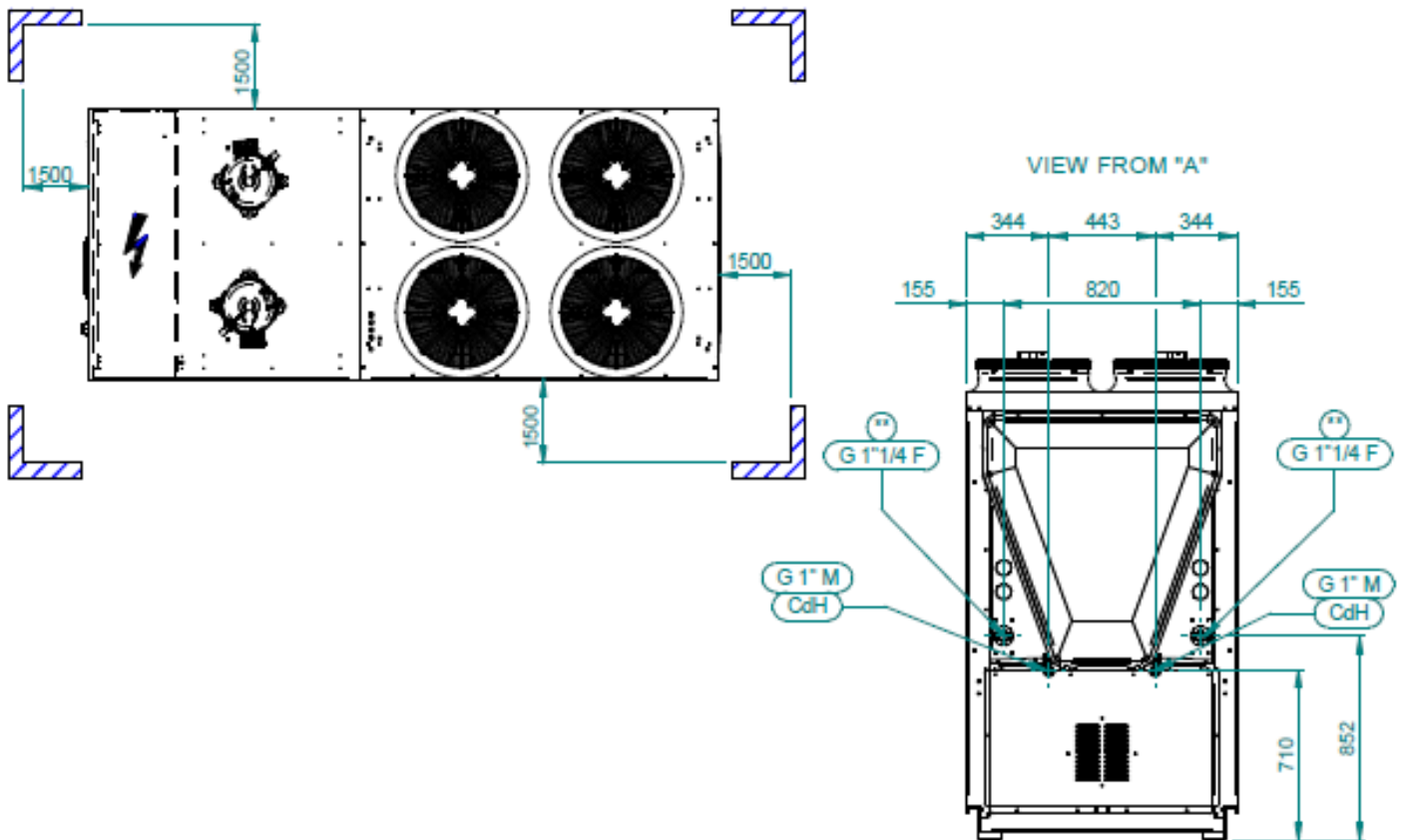
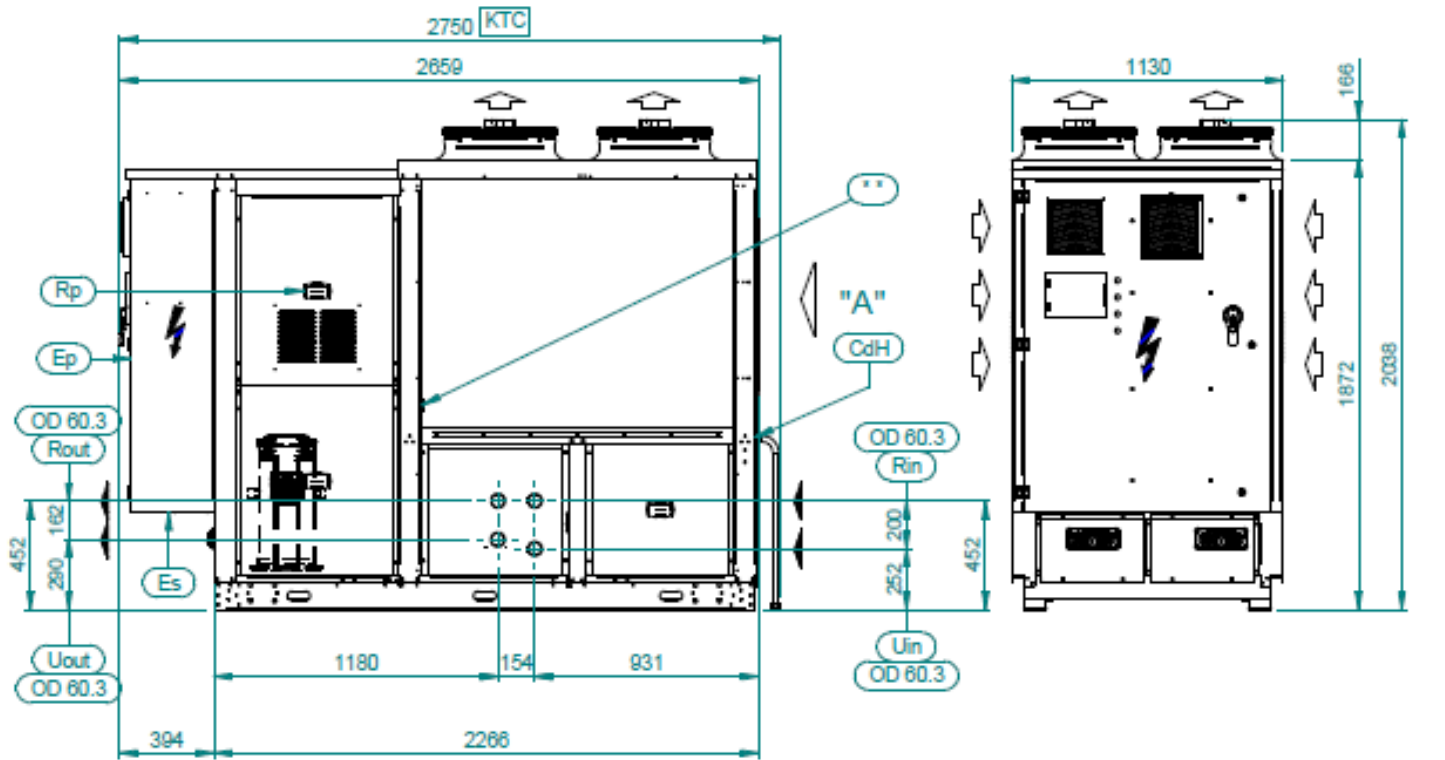

[] SAP CODE OF OPTIONS

** SAFETY VALVE DISCHARGE

Note: These drawings are not contractually binding. For the installation design, refer to the specific dimensional drawing available on request.

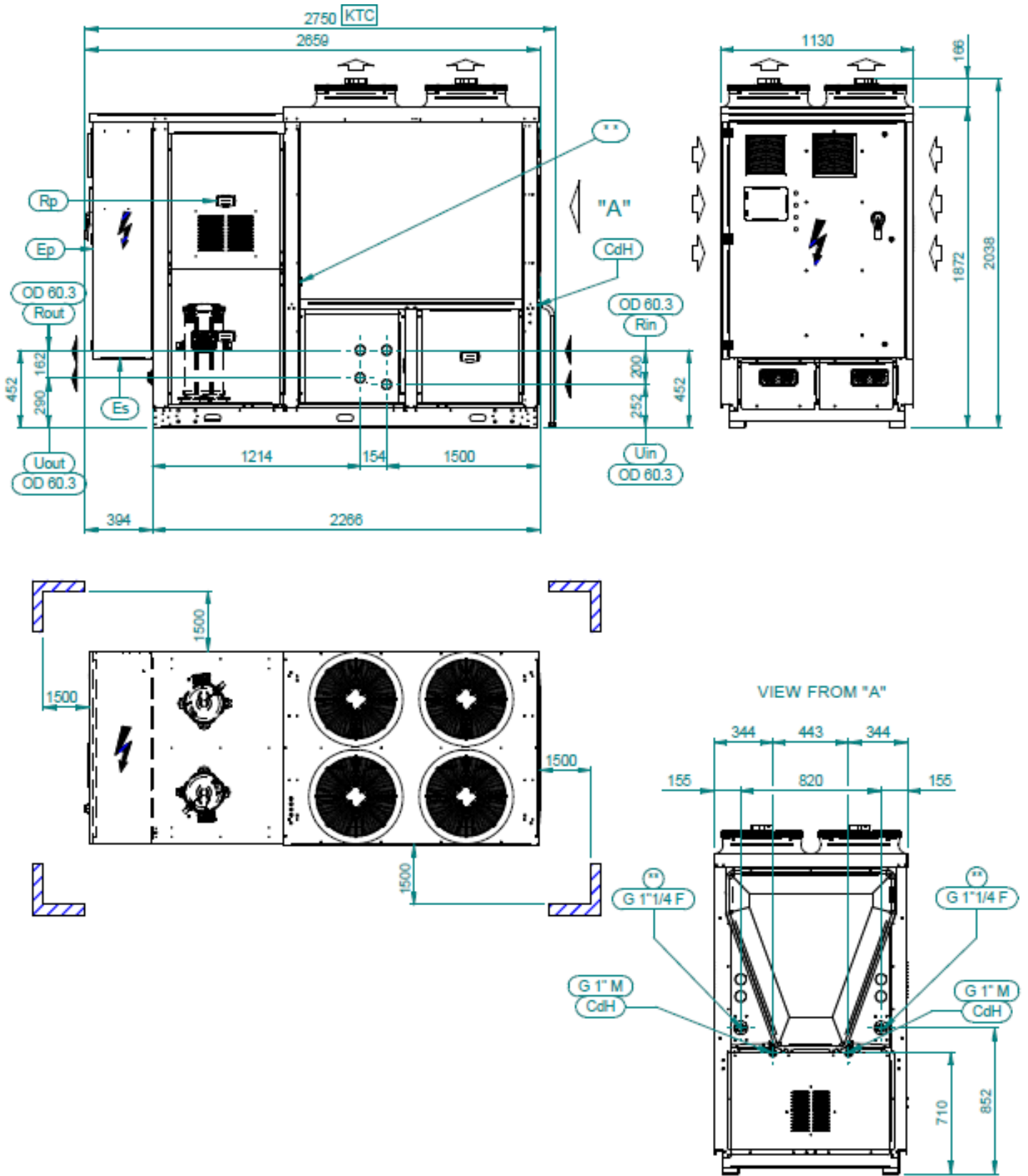

SAP CODE OF OPTIONS

** SAFETY VALVE DISCHARGE

Note: These drawings are not contractually binding. For the installation design, refer to the specific dimensional drawing available on request.

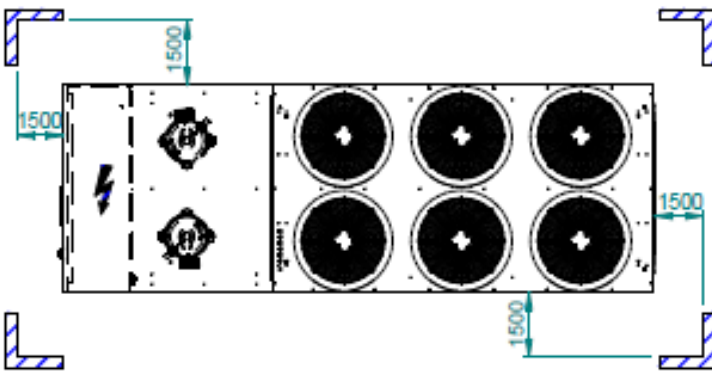
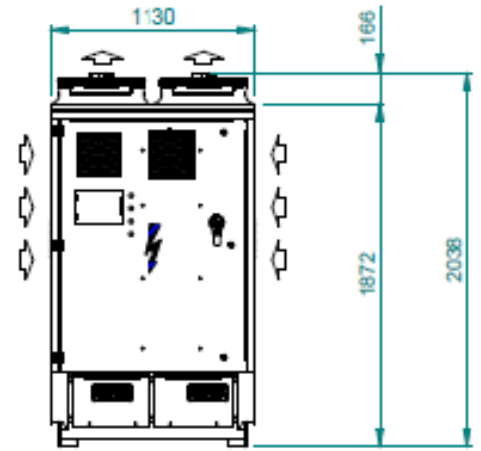
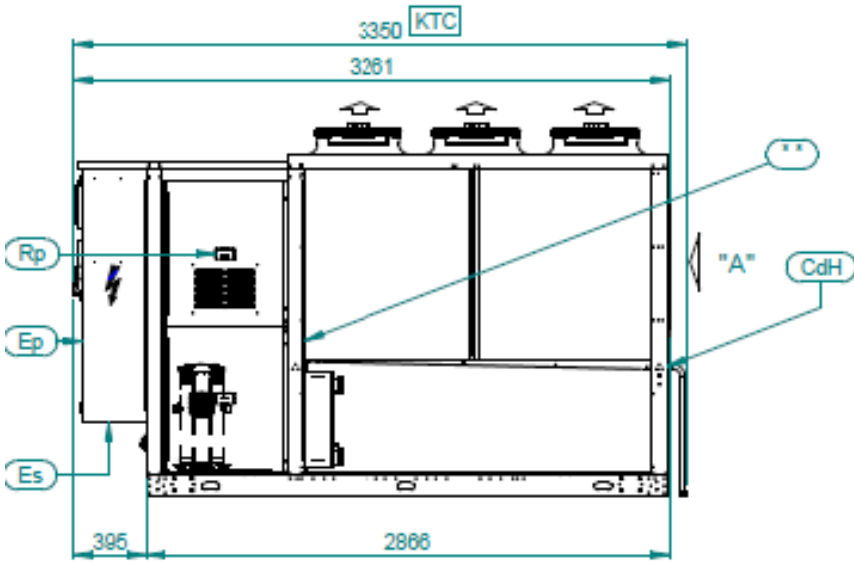

VIEW FROM "A"

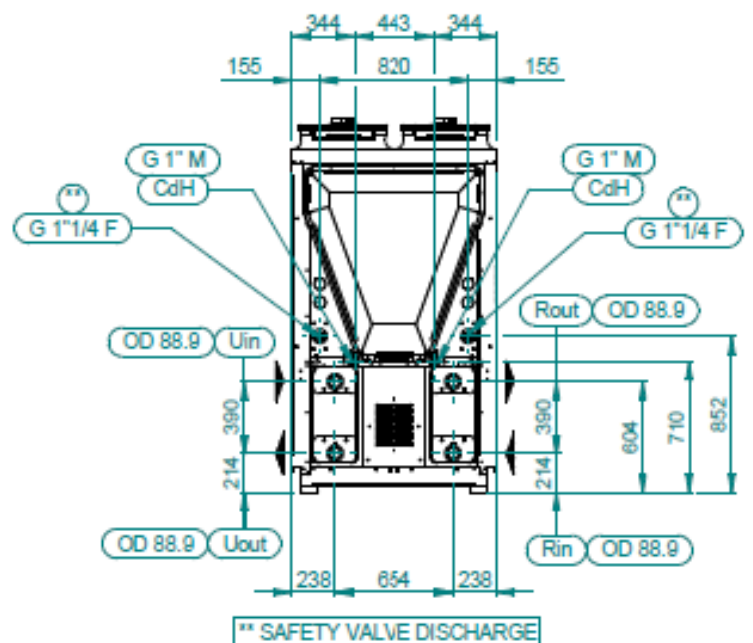

SAP CODE OF OPTIONS

Note: These drawings are not contractually binding. For the installation design, refer to the specific dimensional drawing available on request.

OMICRON ZERO S4 8.2 1P1R-2P2R

DDIM001531

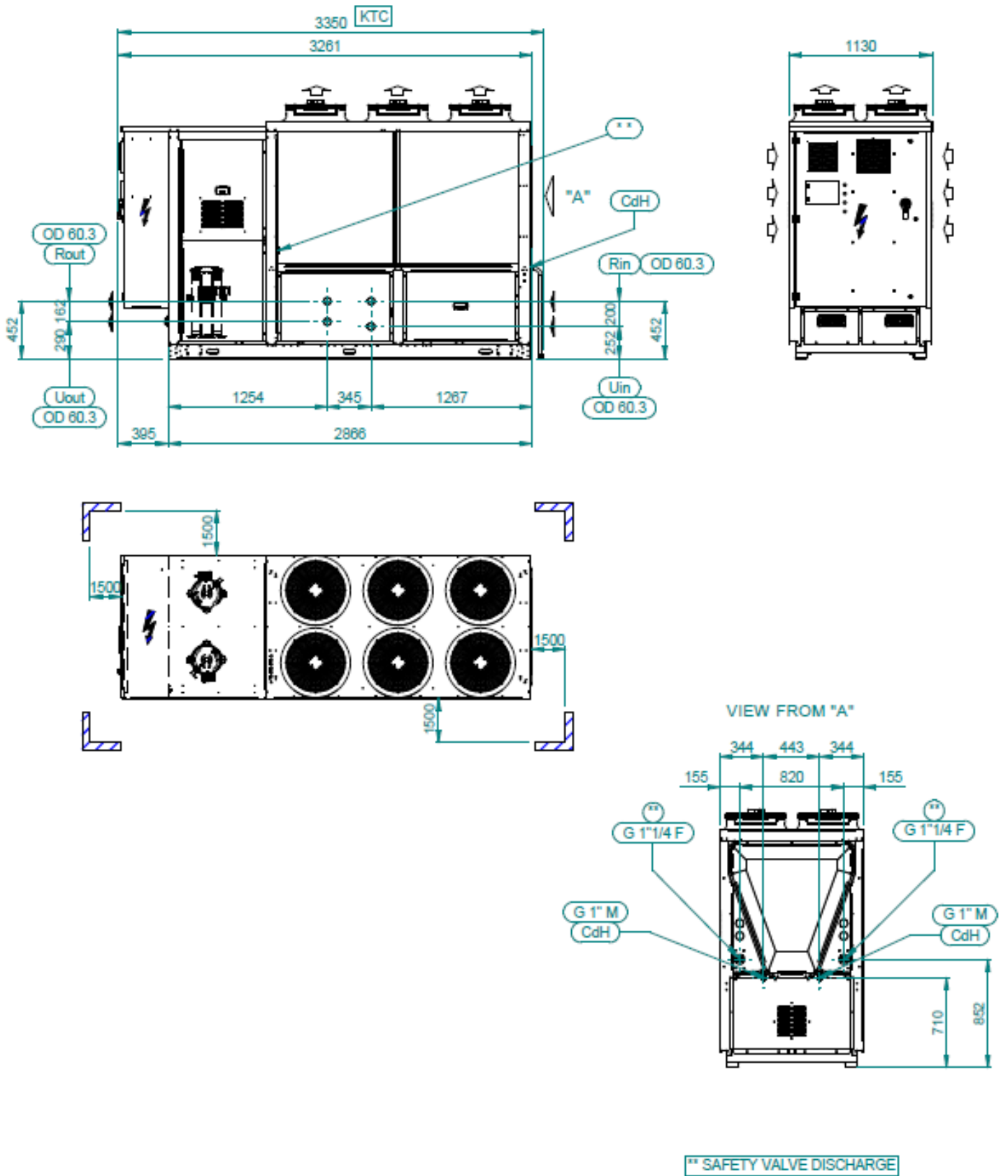

Note: These drawings are not contractually binding. For the installation design, refer to the specific dimensional drawing available on request.

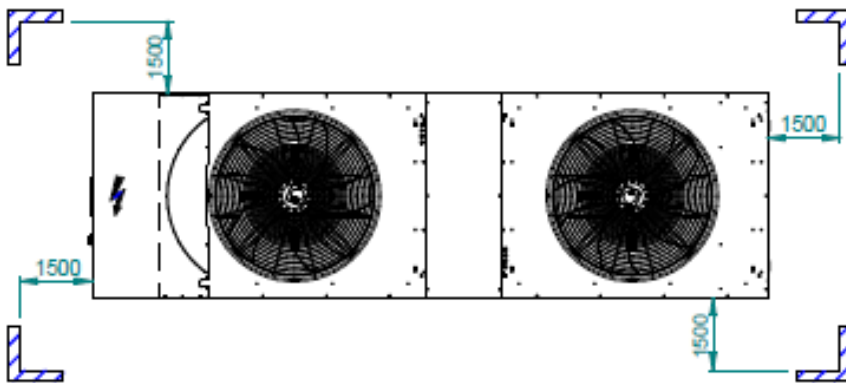
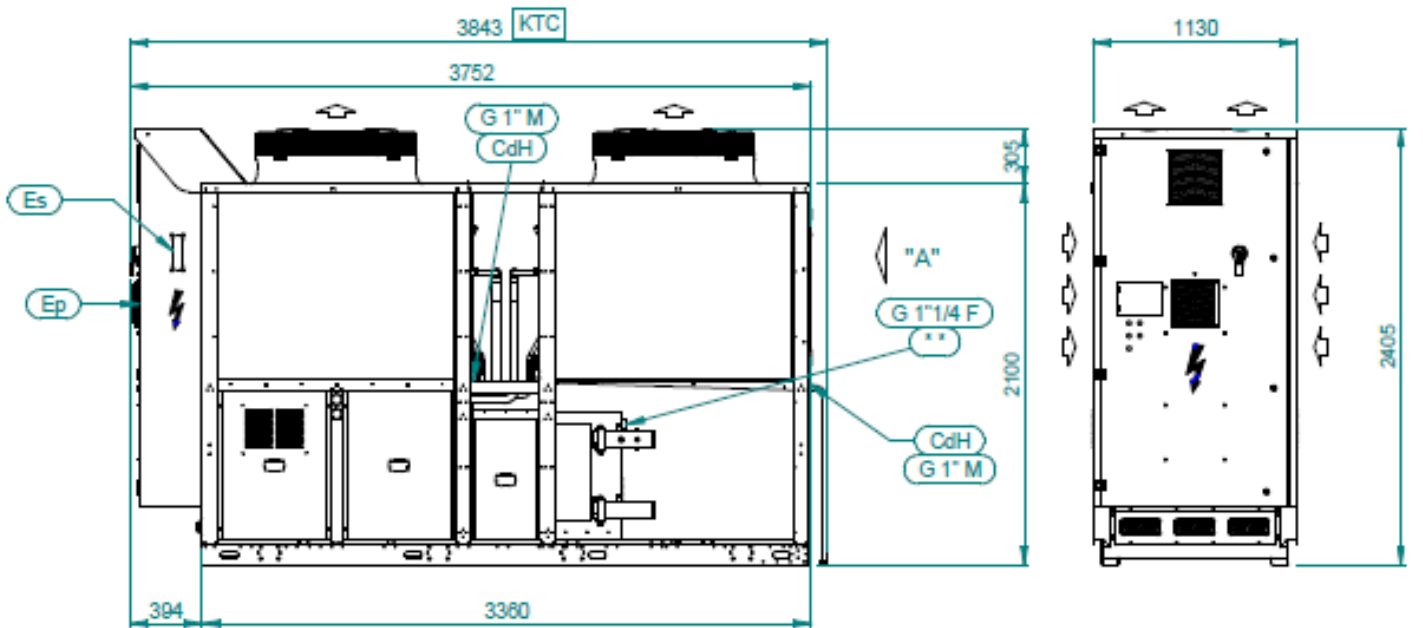

VIEW FROM "A"

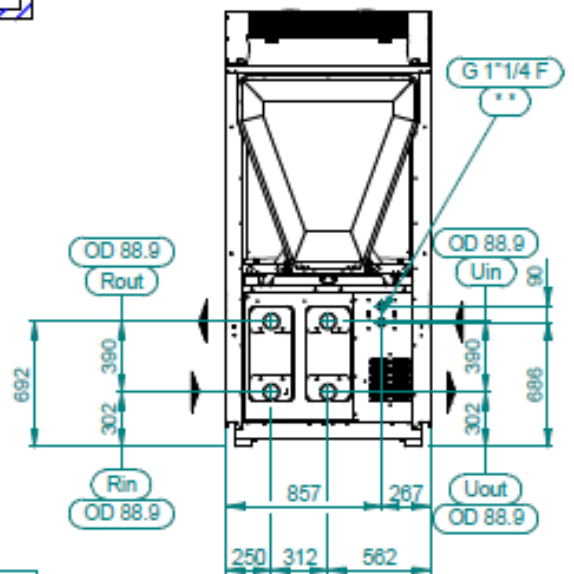

□ SAP CODE OF OPTIONS

** SAFETY VALVE DISCHARGE

Note: These drawings are not contractually binding. For the installation design, refer to the specific dimensional drawing available on request.

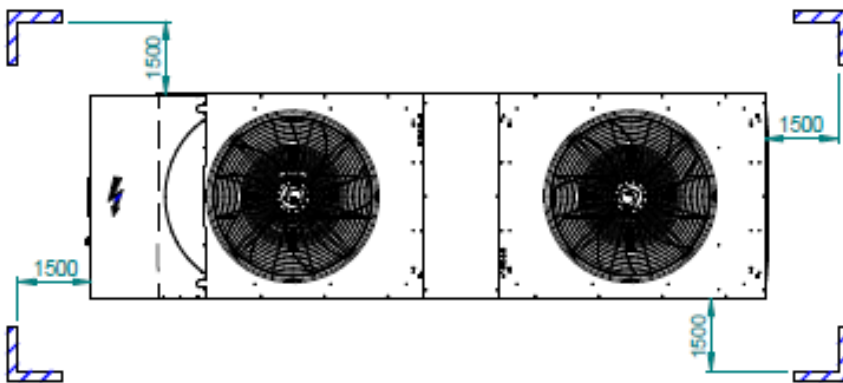
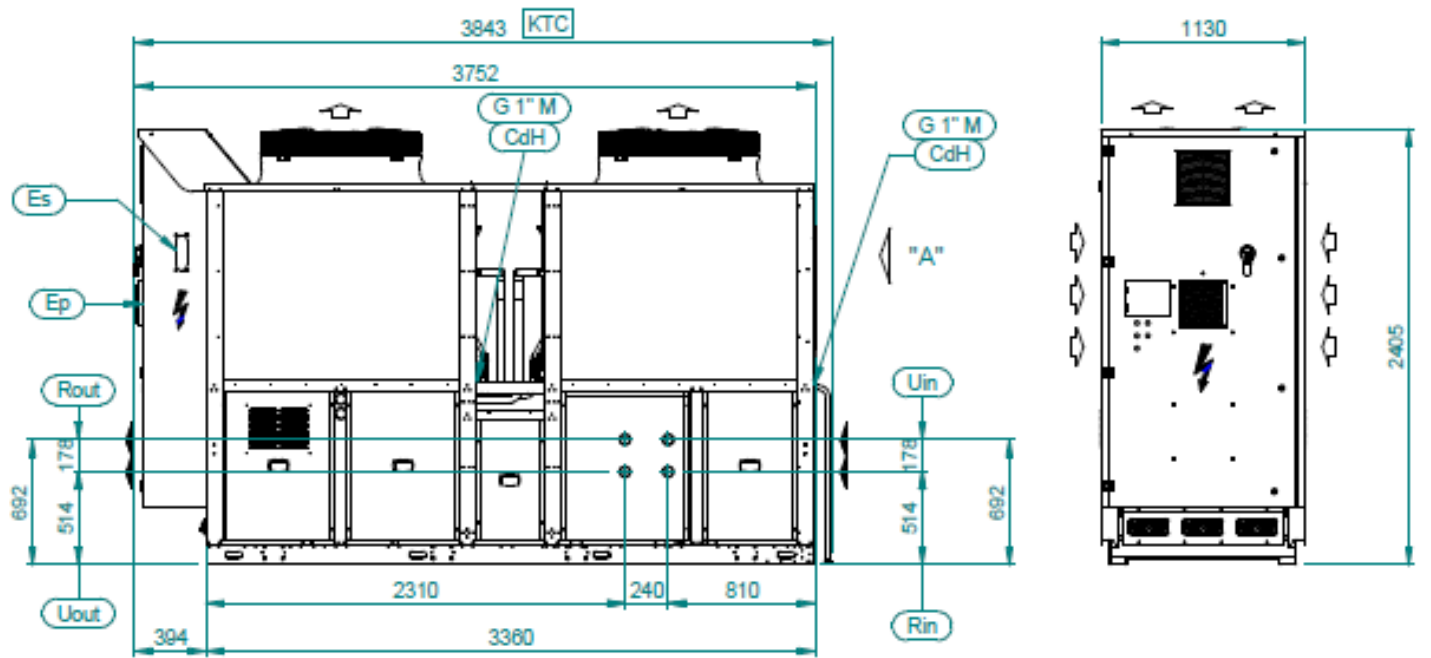

HYDRAULIC CONNECTIONS				
SIZE	Uin	Uout	Rin	Rout
10.4	OD 60.3	OD 60.3	OD 60.3	OD 60.3
12.4	OD 76.1	OD 76.1	OD 76.1	OD 76.1

VIEW FROM "A"

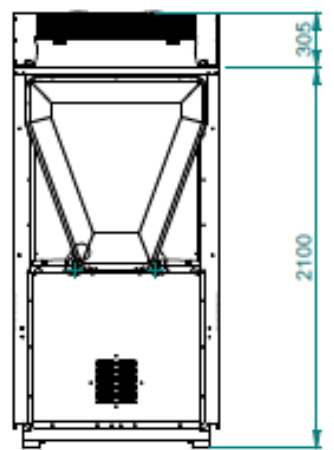
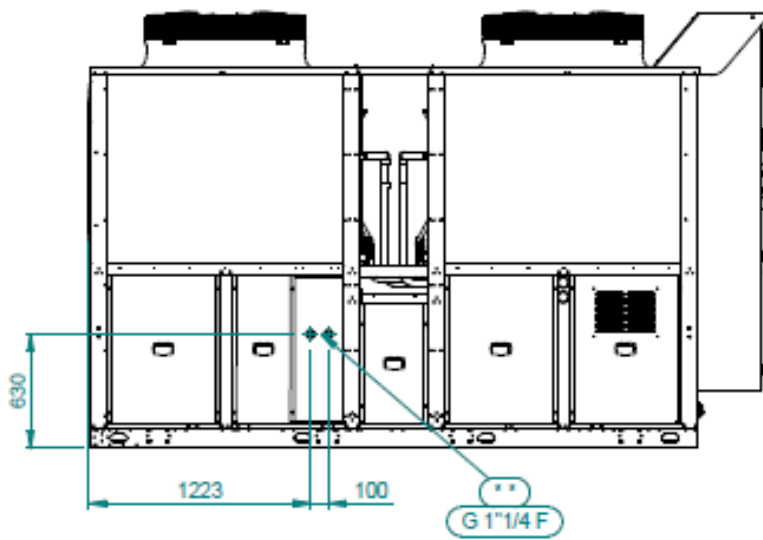

□ SAP CODE OF OPTIONS

** SAFETY VALVE DISCHARGE

Note: These drawings are not contractually binding. For the installation design, refer to the specific dimensional drawing available on request.

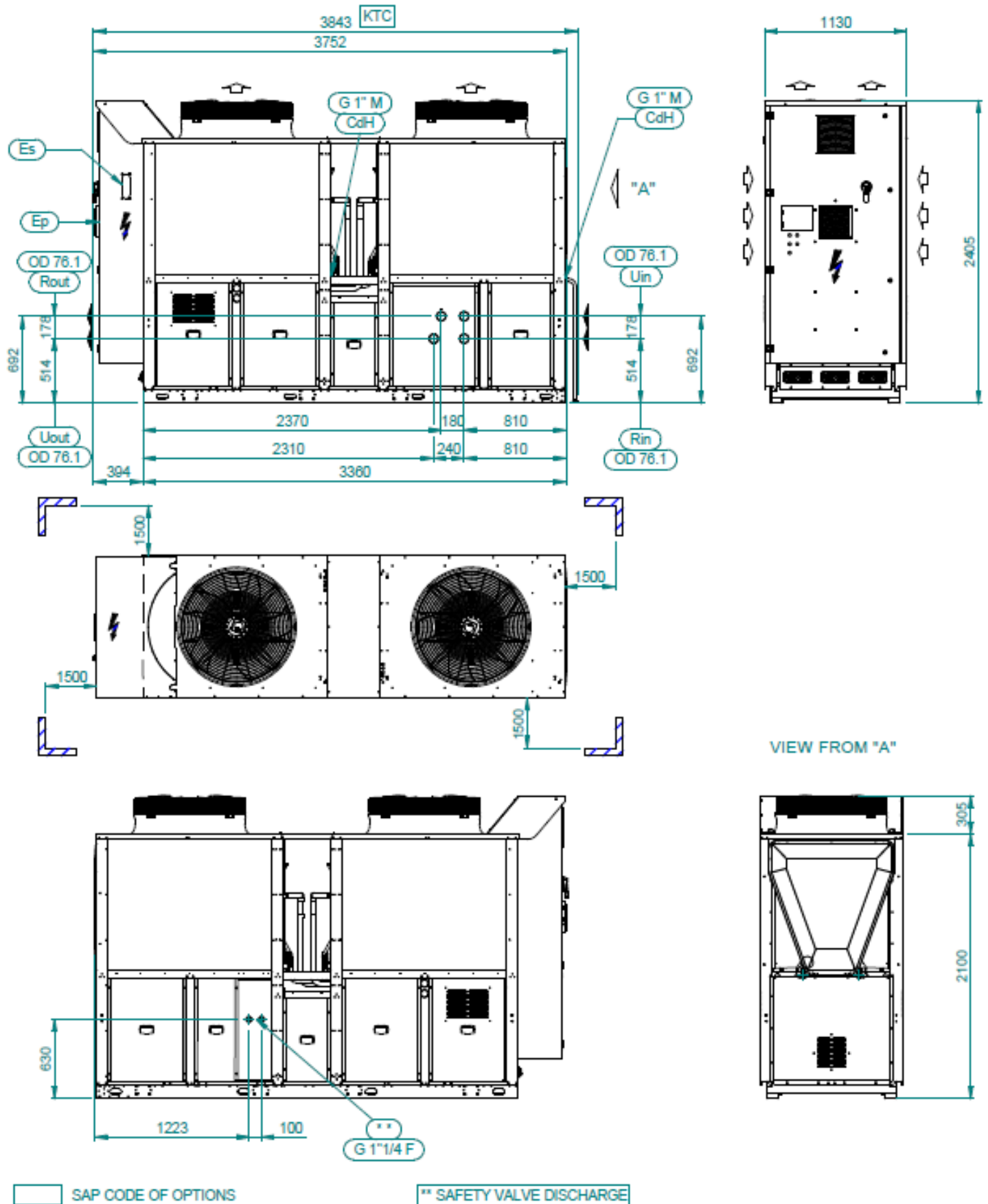

Note: These drawings are not contractually binding. For the installation design, refer to the specific dimensional drawing available on request.

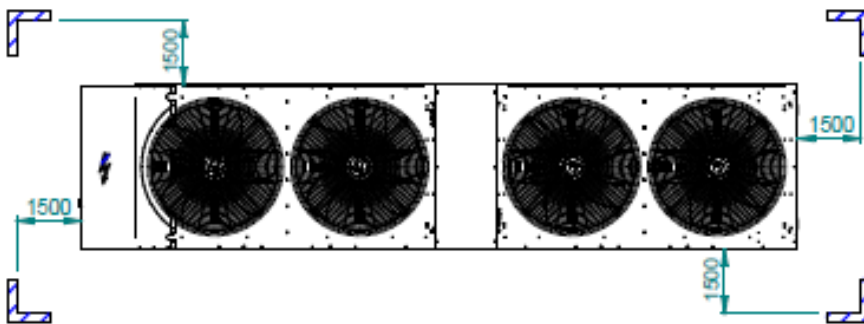
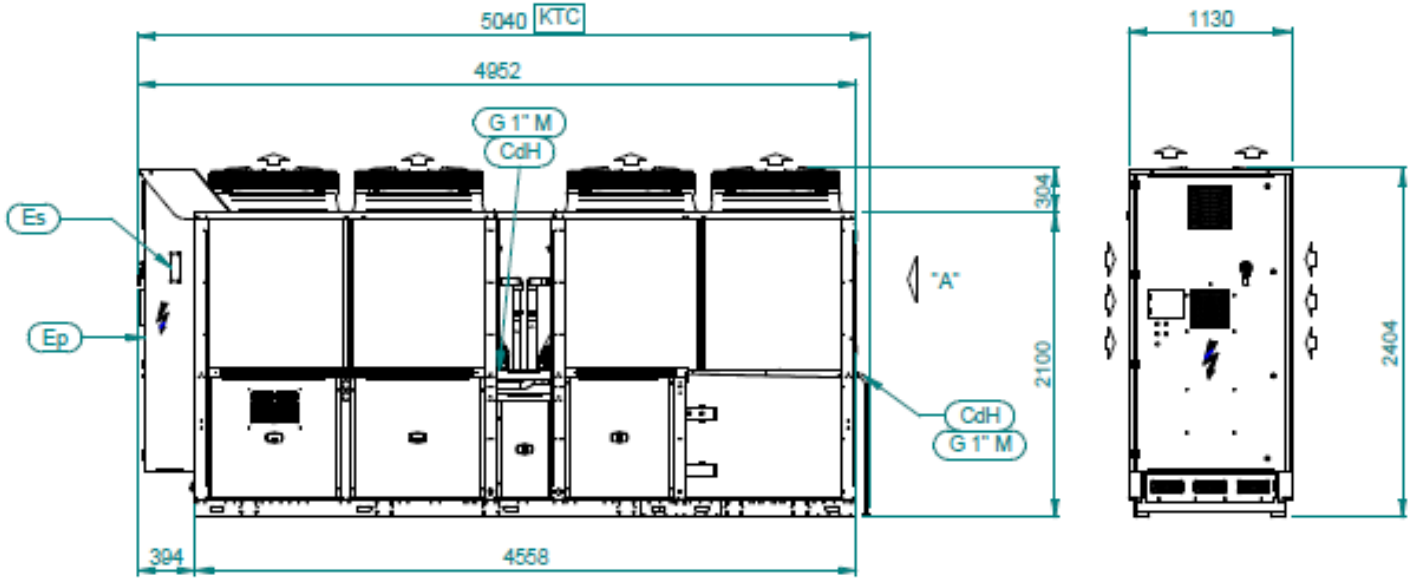

VIEW FROM "A"

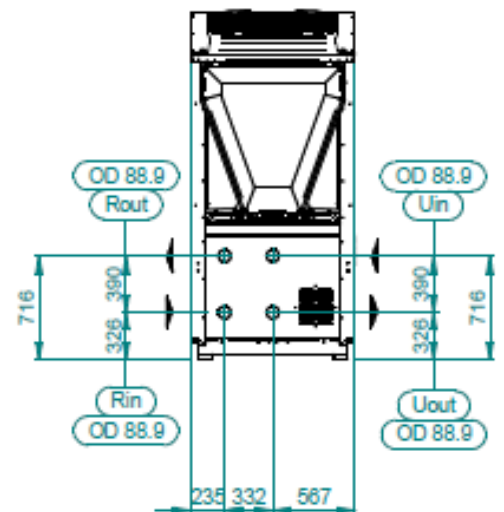
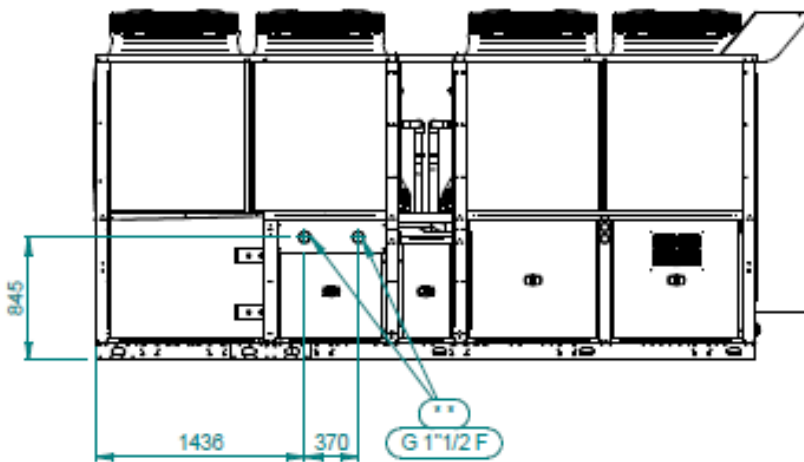

SAP CODE OF OPTIONS

SAFETY VALVE DISCHARGE

Note: These drawings are not contractually binding. For the installation design, refer to the specific dimensional drawing available on request.

OMICRON ZERO S4 16.4 1P1R-2P2R

DDIM001567

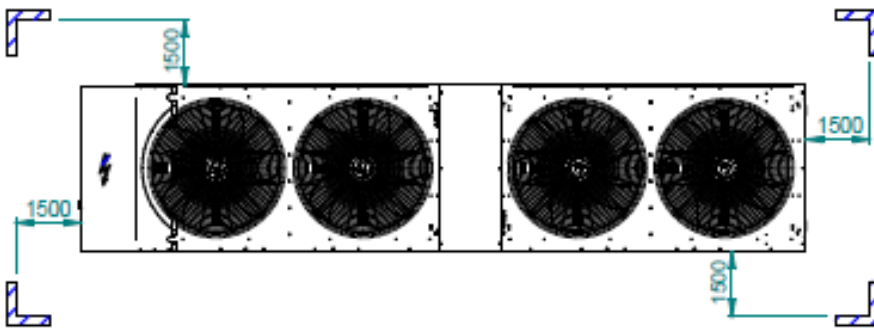
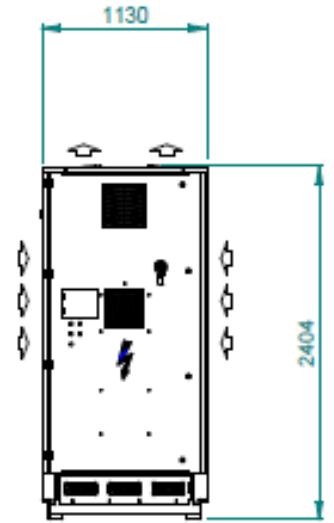
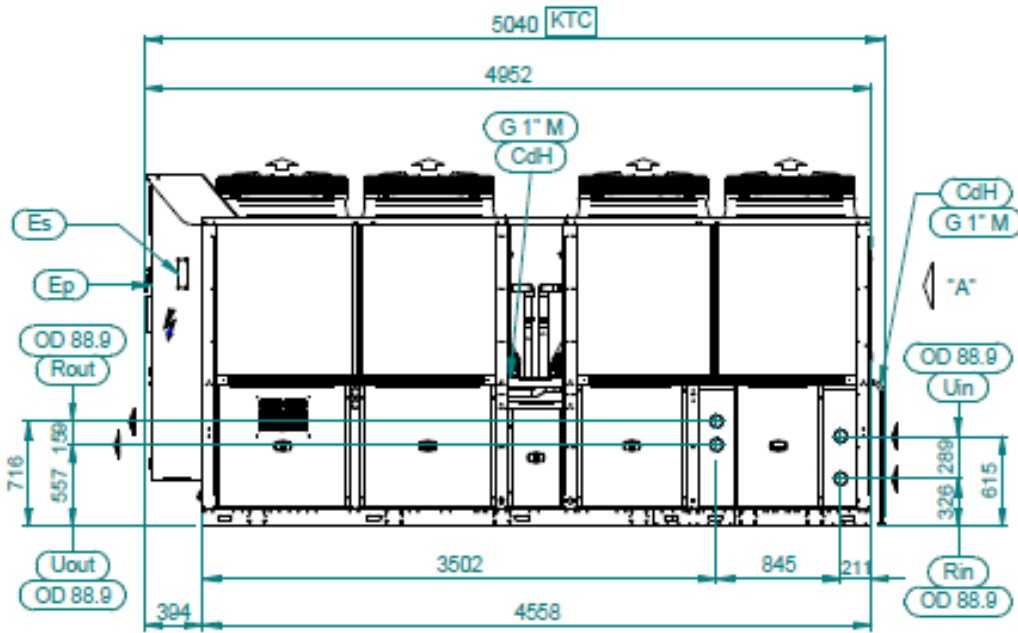

VIEW FROM "A"

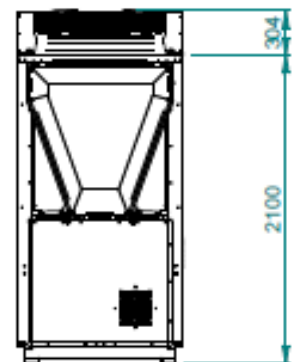
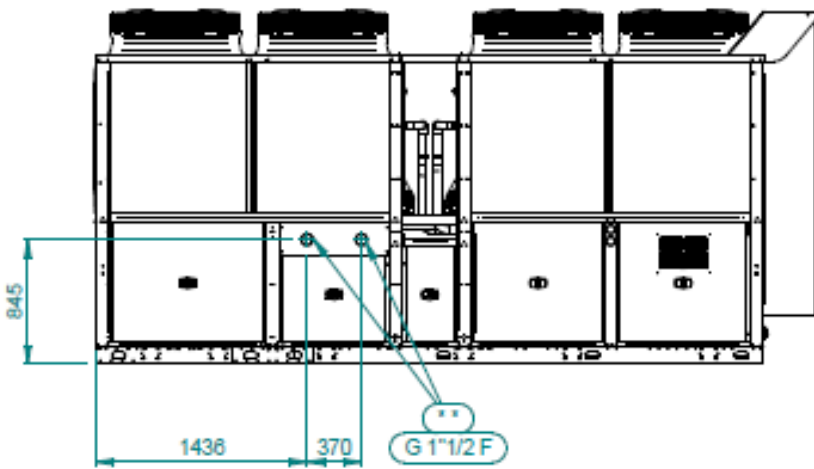

SAP CODE OF OPTIONS

** SAFETY VALVE DISCHARGE

Note: These drawings are not contractually binding. For the installation design, refer to the specific dimensional drawing available on request.



Swegon Operations s.r.l.

Via Valletta, 5 - 30010

Cantarana di Cona, (VE) Italy - T. +39 0426 921111 - F. +39 0426 302222

www.blueboxcooling.com - info@bluebox.it



Swegon Operations s.r.l. a socio unico - P.IVA 02481290282

Company directed and coordinated by Investment Latour (Sweden)