



Omega Sky



High-speed cold water generator and heat pump with semi-hermetic screw compressors





Omega Sky Series



High-speed cold water generators and heat pumps with semi-hermetic screw compressors, tube-bundle heat exchangers and optional sliding free cooling for interior installation.

Configuration:

- CH:** Cold water generator
- HPW:** Heat pump, reversible on hydraulic side
- OH:** non-reversible heat pump
- LN:** Low Noise
- XLN:** Super Low Noise
- LC:** Evaporator unit for external condenser
- DC:** 100% heat recovery
- FC/NG:** Free cooling management with glycol-free consumer circuit
- XEi:** Inverter-controlled screw compressors

Omega Sky series - Key facts:

- ECODSIGN compliant (ErP 2018)
- High efficiency in part-load range ESEER up to 6.37 and SEER up to 6.38
- Possible refrigerants: R513A (GWP 573), HFO 1234ze (GWP<1) or R134a (GWP 1,430)
- Reduced refrigerant charge
- Easy handling: Depth $\leq 900\text{mm}$ in units with single compressor
- Sliding free cooling management (FC/NG version optionally available)
- Advanced Blue Think® control with integrated web server, MULTILOGIC function and Blueeye monitoring system (optional)
- Also available as fully inverter-controlled and hybrid version



Omega Sky



e.g. refrigerant R513A:

- non-flammable
- low GWP

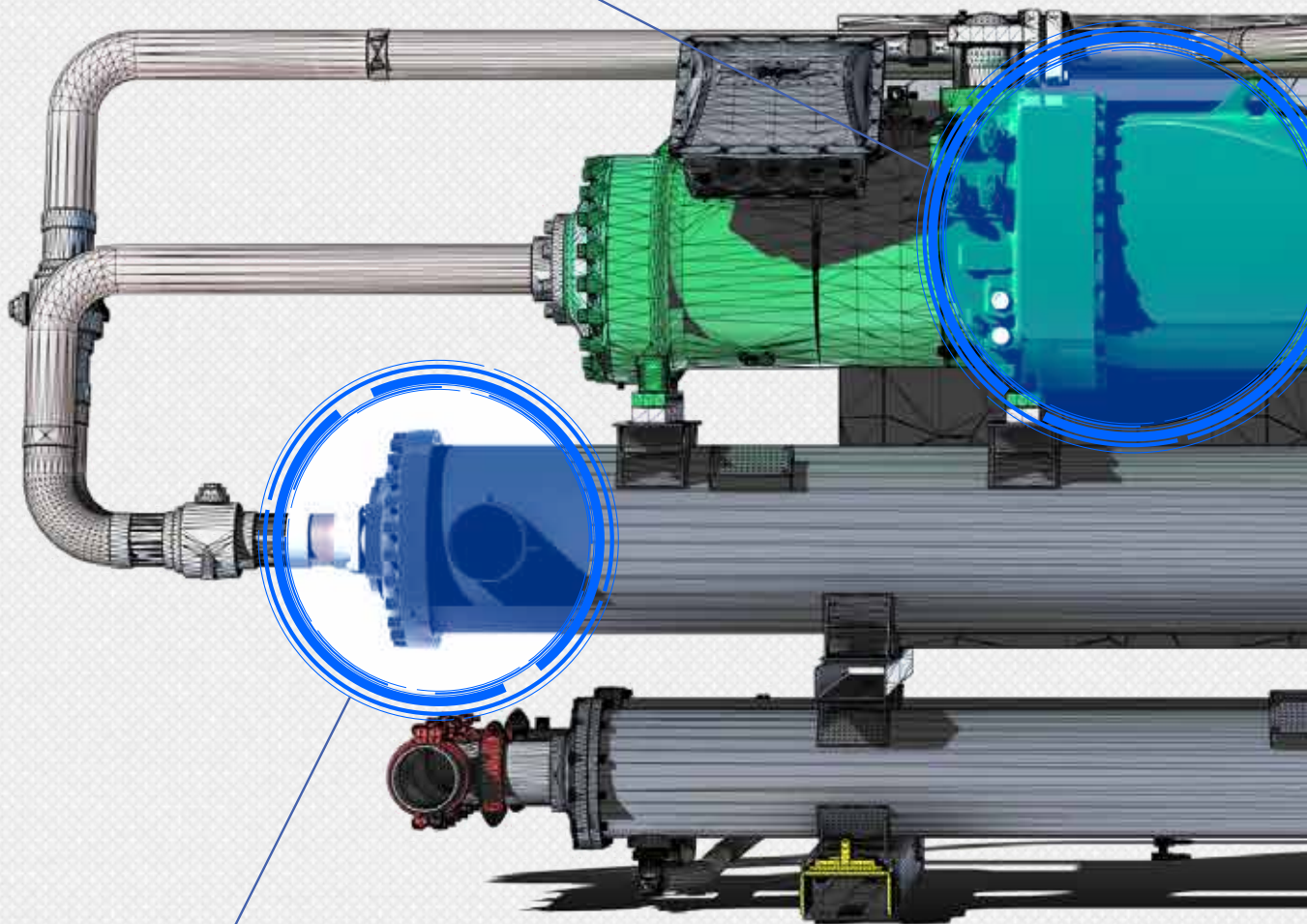

**High-efficiency evaporator
with dry expansion**

low refrigerant usage, low pressure loss

Blue Think® control

Web server
Blueeye monitoring system
Multilogic function

**Excellent
efficiency
with part-loads**

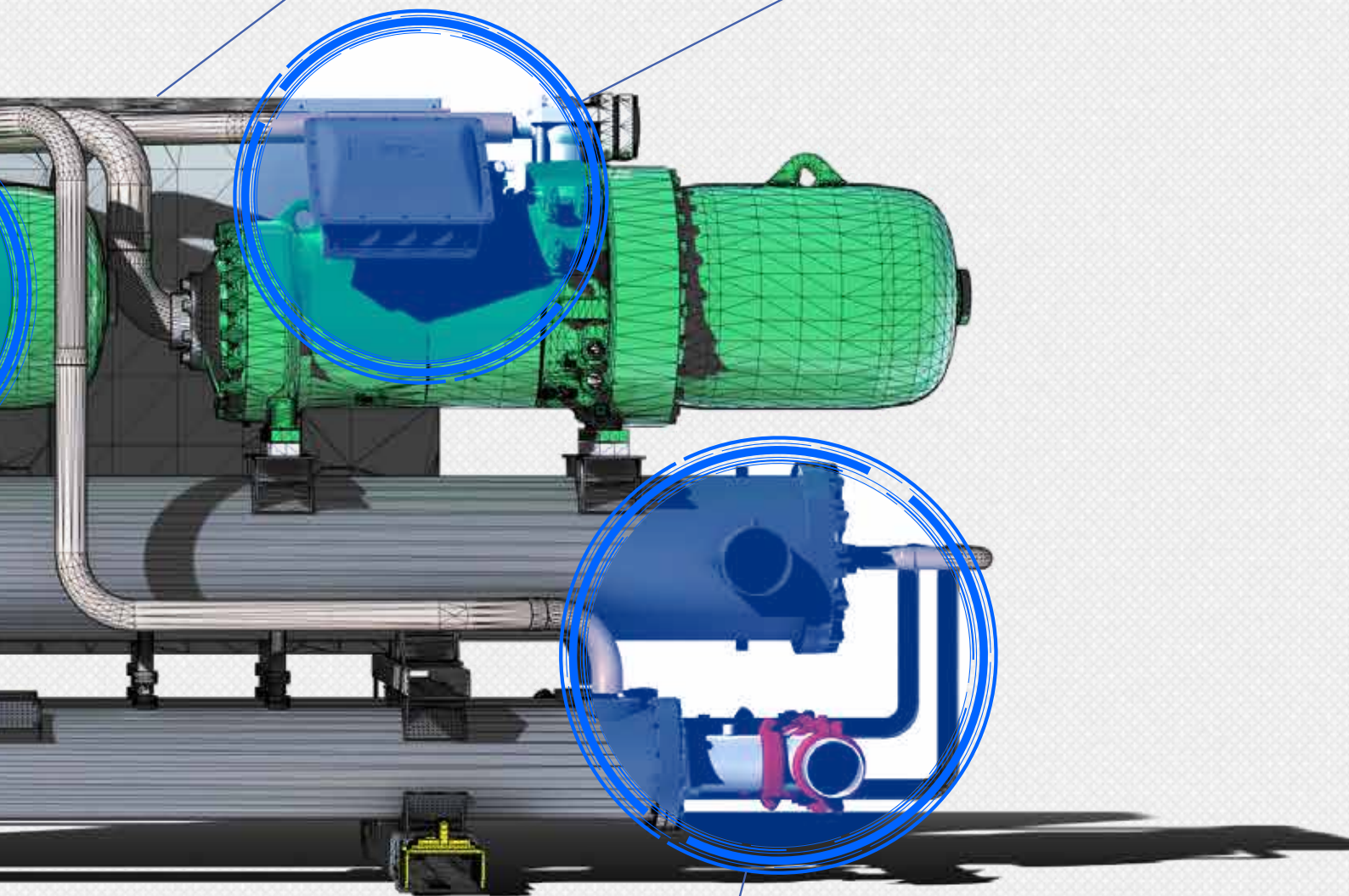

**Plug & Play
for easy
interior installation**



Omega Sky & Omega Sky FC/NG versions



The new Omega Sky series of internally installed cold water generators and heat pumps with screw compressors was developed with special regard to changing coolant situations and rising efficiency requirements of Ecodesign directives. This device series meets the requirements of Ecodesign directive 2281/2016. All models with R513A or R134a are EUROVENT-certified.

The performance range is from 430 to just under 1,600 kW cooling capacity. Depending on requirements, 1–2 infinitely variable standard or speed-controlled screw compressors are fitted. Omega Sky FC/NG has a special option of integrated control of a sliding free cooling unit.

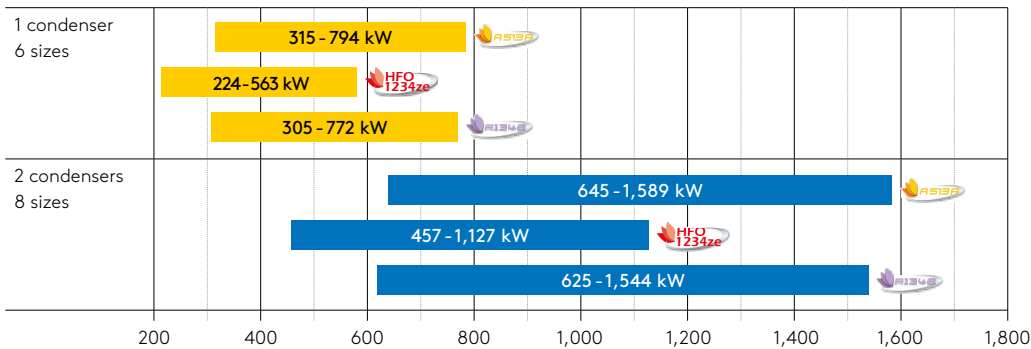

Omega Sky FC/NG version

Device version Omega Sky FC/NG combines continuous performance control of the screw compressors with a control system for sliding free cooling. This system ensures the delivery of highly accurate flow temperatures to users. Sliding free cooling also significantly reduces the system's operating costs.

By using external air as a cooling system there is no need for mechanical cooling when outside temperatures are low. The integrated Blue Think control calculates the optimal utilization of the external dry cooler, whether as recooling heat exchanger, whether as recooling or as free-cooling heat exchanger. This enables an infinitely variable reduction of screw compressor usage.

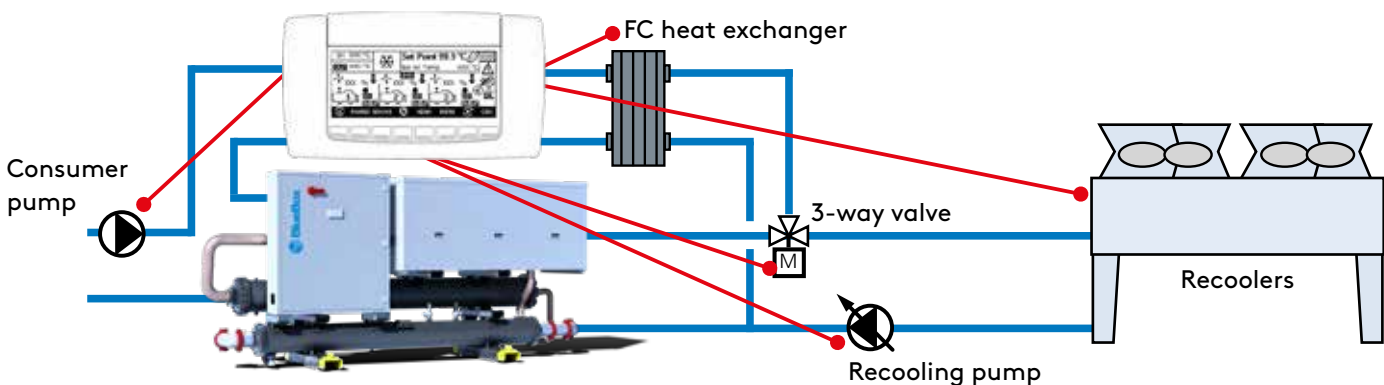

Free-cooling pays off!

The free-cooling function units meet the rising demand for energy saving: they were developed in order to reduce operating costs of cooling machines which, for longer or shorter periods throughout the year, run with low ambient temperatures.

The strength of the Omega Sky FC/NG with free-cooling function lies in its control system.

Outside air can be utilized as a free resource, thereby substantially reducing the amount of energy required by the compression system. Focusing on energy saving, the control unit activates the appropriate operating mode on the basis of temperature probe readings of outside air and return flow temperature.



Operating modes

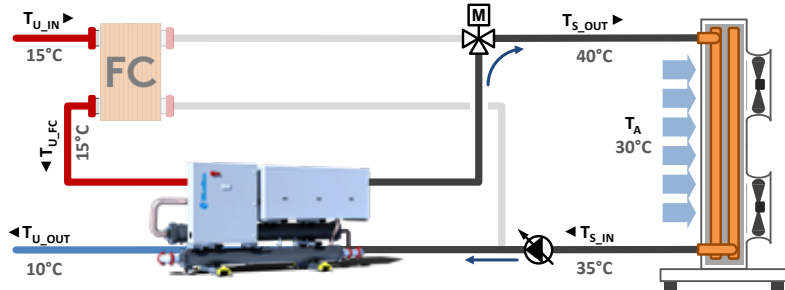

Summer operation (100% mechanical cooling)

In exclusively mechanical cooling mode, because outside temperatures are too high to start free cooling, Omega Sky FC/NG operates like a normal cold-water generator. The 3-way valve is fully open to the condenser but fully closed to the free-cooling plate heat exchanger. Should a condensing pressure control be required at this stage, this task is performed by the frequency converter for the cooling water pump. Path A-AB of the 3-way valve is open. The recoler operates in recoling mode, and the nominal value is 35°C.

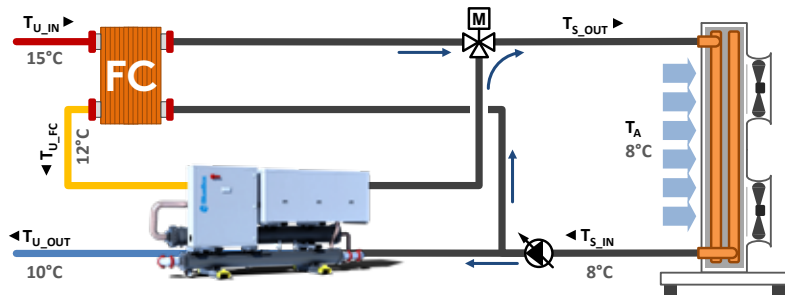

Combined operation (mechanical and free-cooling)

Whenever the outside temperature is 3-4 K lower than the return flow temperature, the free-cooling unit is activated. The unit operates in transition mode. The nominal value at the external recoler is changed from 40°C to 8°C. The cooling water pump operates at 100% to utilize the full free-cooling capacity. To ensure stable operation of the compressors, the 3-way valve is continuously regulated in line with the condensing pressure.

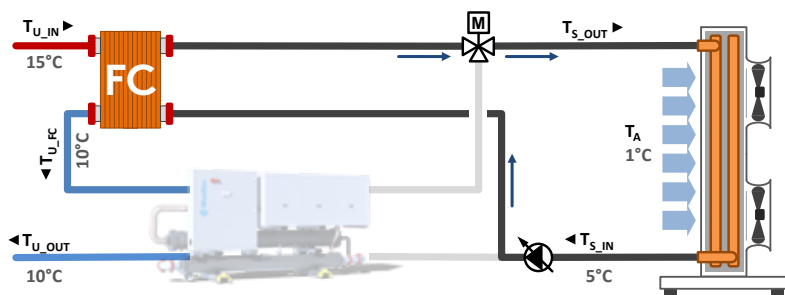

Winter operation (100% free cooling)

Full cooling capacity via free cooling: When the outside temperature reaches a level that allows the recolers to undertake the full cooling capacity, the 3-way valve is opened fully to the free-cooling plate heat exchanger and the compressor operation is stopped. To ensure that the flow temperature of the cold-water generator is not reduced too much when outside temperatures are very low, the airflow rate at the recoler is adjusted via a speed regulator.

The components (free-cooling plate heat exchanger, frequency converter pump and 3-way valve) are not included in the standard delivery, but are optionally available.

Compact design

Easy fitting and high-performance installation

In addition to its energy efficiency, Omega Sky also has a highly compact design. Unit sizes with semi-hermetic screw compressor have a maximum depth of 900mm and a height of 1,983mm (max. cooling capacity approx. 800 kW). For existing buildings, this allows fitting through standard door sizes.

A connection via flange is optionally available

(Standard Victaulic). For units with two cooling circuits a ready-made, prefabricated tube connection for the two tube-bundle heat exchangers is optionally available.

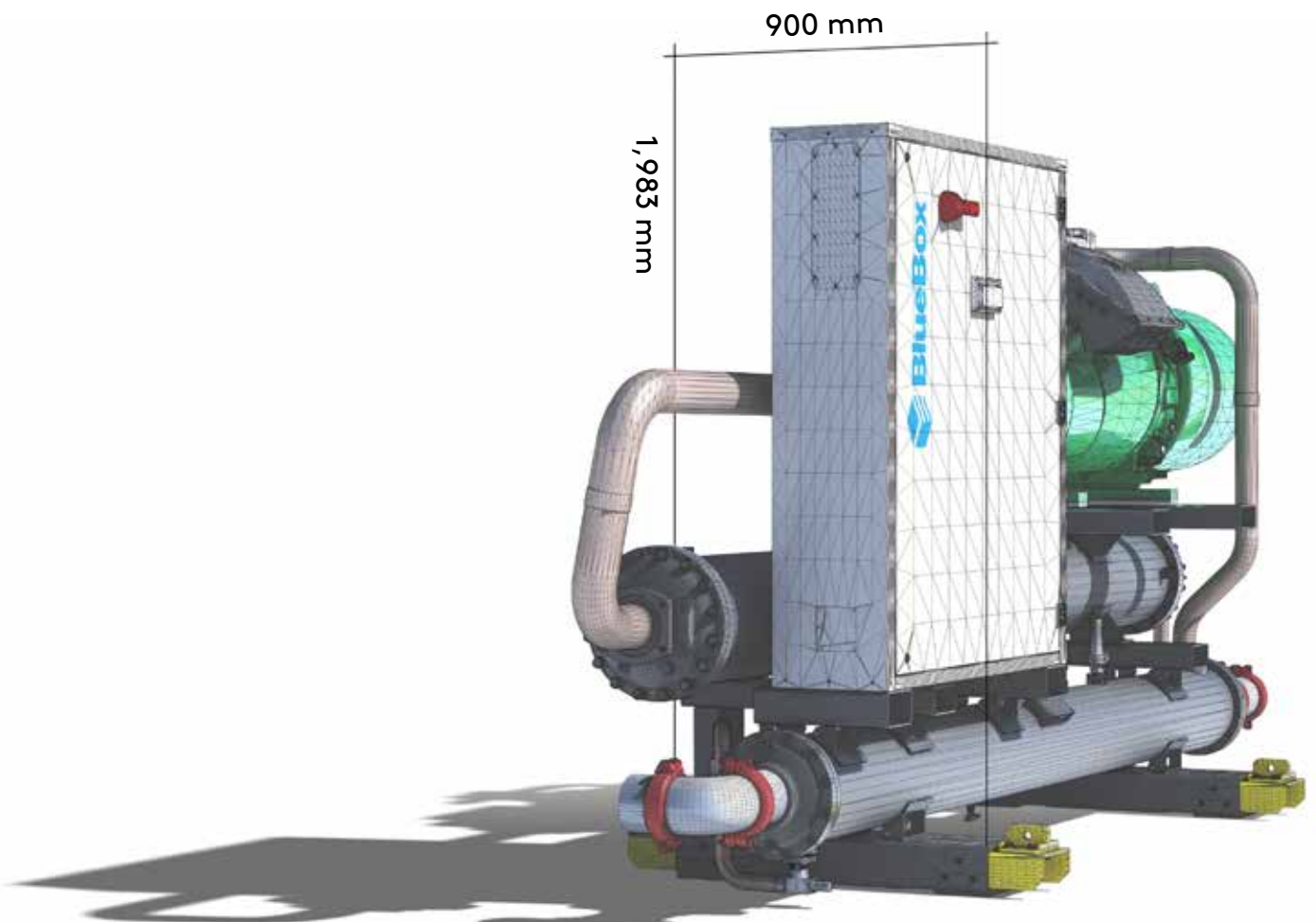

Innovative technology

Blue Think® is the latest "Plug & Play" device by BlueBox. The entire function and control logic was developed by our in-house "Systems & Control Team". One major advantage of the comprehensive software development by BlueBox is that it enables fast reactions to changing market needs. Plus: The development of functions for system optimization, system integration and monitoring.

Generator regulation: Regulation for intelligent control of cold water generators and heat pumps.

Hydraulics regulation: Hydraulics optimization by adapting volume flows to load conditions.

Flowzer VP: Inverter for manual pump settings.

Flowzer VD: Differential pressure transducer for automatic adjustment.

Flowzer VFPP: Installation set for variable primary pump volume flow rates

Consumer regulation: Needs-based regulation of generators by consumers using e.g. smart/data links.

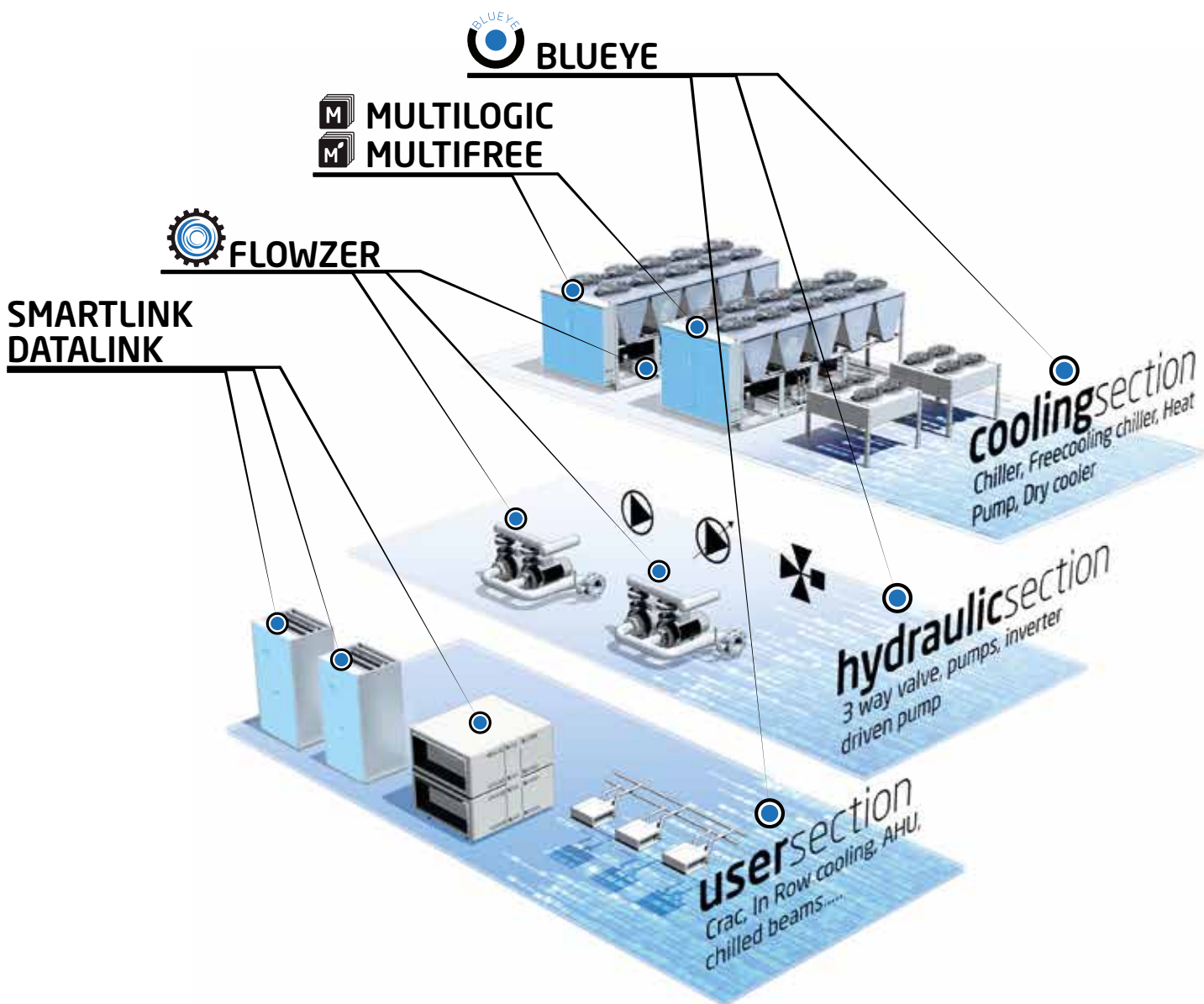

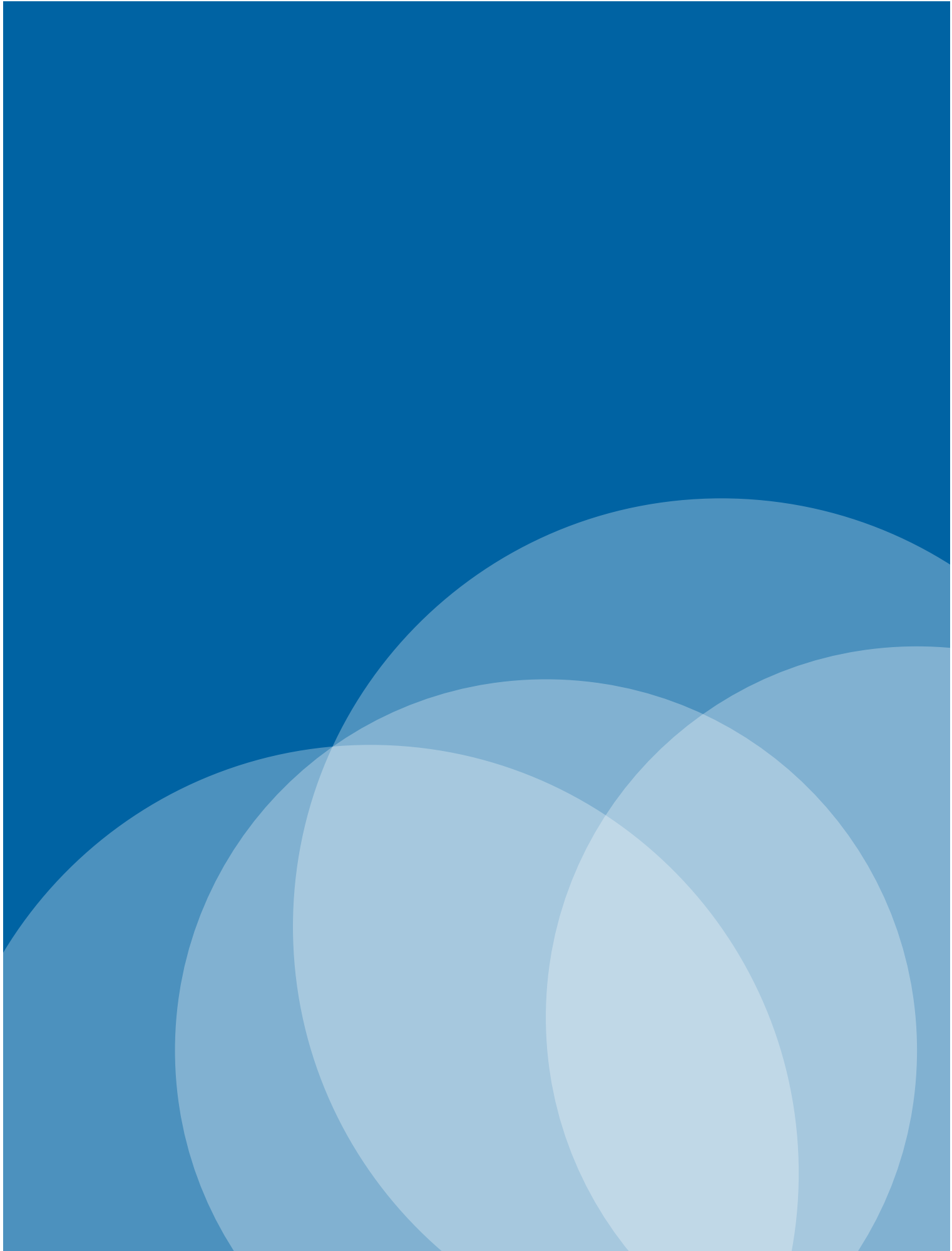

Blue Box Group S.r.l.
Via Valletta, 5 - 30010 Cantarana di Cona, (VE) Italy
www.blueboxcooling.com - info@swegon.it
Phone +39 0426 921111 - Fax +39 0426 302222