

Omega Sky Xi

253÷940 kW



General

Water-condensed liquid chillers and heat pumps for indoor applications; screw compressor with variable compression ratio and inverter for capacity modulation.

Configurations

OH: non-reversible heat pump

HPW: reversible heat pump on water side

/LN: low noise version

/XLN: super low noise version

/DC: with total recovery

Strengths

- ▶ Maximum efficiency at partial loads: SEER up to 8,3 and SEPR up to 9,3
- ▶ Ecodesign Tier 2 compliant
- ▶ Non-flammable refrigerant R513A, with GWP=573
- ▶ Hybrid Falling Film evaporator with low refrigerant load
- ▶ Variable Vi screw compressor with external inverter
- ▶ Version with chiller and heat pump, each with optimised operating range
- ▶ BlueThink advanced control with integrated web server. Multilogic function and Blueeye® supervision system. (options)

BlueBox 
by Swegon

Omega Sky Xi

Technical specifications

7

Ecodesign

11

RANGE OMEGA SKY Xi

Installation advice

17

Water characteristics

17

Glycol mixtures

17

Minimum water content in the system

18

Installation site

19



Omega Sky Xi

Omega Sky Xi is a water-condensed liquid chiller for indoor applications, available in heat pump version also.

This range features a semi-hermetic, inverter-controlled screw compressor to obtain maximum performances at partial loads, a latest generation Hybrid Falling Film evaporator with low refrigerant load, and a shell and tube condenser.

These elements make Omega Sky Xi an extremely performing machine in all operating conditions, which enables it to largely exceed the targets mandated by the existing regulations and to ensure maximum comfort levels.

REFRIGERANT

Refrigerant R513A (GWP=573*) standard.

The refrigerant consists in a blend of R134a (44%) and R1234yf (56%), with temperature glide equal to 0.

R513A is classified as a non hazardous fluid (Group 2 fluid under PED).

It is also included in Class A1 under the ASHRAE Standard 34:

- non-toxic;
- non-flammable.

These characteristics make R513A ideal for indoor installations.

The excellent GWP value may be an advantage in projects where:

- min. targets are adopted for the containment of the environmental footprint;
- it is possible to receive incentives or other benefits that are applicable in some countries or are connected to specific plant design criteria.

This also goes to the benefit of unit installation, commissioning and maintenance as it reduces the overall management costs.

STRUCTURE

Consists of polyester powder coated hot dip galvanised sheet steel profiles (RAL 9005).

The electrical control panel is made in a polyester powder-coated hot dip galvanised sheet steel box (RAL 7035).

COMPRESSORS

Units fit innovative screw compressors with a variable compression ratio, which ensure optimised operation under all operating conditions.

The BlueThink controller constantly monitors the evaporating and condensing temperatures of the unit and changes the compression ratio of the compressors to obtain the maximum achievable efficiency.

The compressors in use are designed according to an exclusive BlueBox specification in order to achieve maximum efficiency both under partial and full load conditions.

Continuous reduction of the output capacity is implemented with a regulation from 25% to 100% in order to achieve the highest energy efficiency levels on the market, with special reference to cooling applications. The variation of the compression ratio caused by the sliding of the internal slide valve, in combination with capacity reduction of the refrigeration demand by the inverter, allows for the maximisation of the energy efficiency of the unit in all operating conditions.

In addition to managing capacity modulation, BlueThink also controls all safety devices so that the compressor can operate within its operating limits at all times and simultaneously safeguard its operation and reliability. Compressor lubrication is ensured by the pressure difference between the delivery and the suction lines, thanks to the regulation action performed by BlueThink.

All the compressors are fitted with check valve on delivery side, metal mesh filter on suction side and electronic protection with temperature sensors directly inserted in the windings and on the delivery pipe.

Startup in compressors featuring an inverter is of the "Direct On Line" type with an inverter-controlled acceleration ramp that minimises inrush currents.

In addition to the obvious energy savings arising from greater efficiency, the use of a full inverter unit also brings advantages in terms of installation:

- For these units, the $\cos\phi$ (power factor) is always greater than 0.95, therefore making external power factor correction systems unnecessary.
- The maximum inrush current of the unit is always lower than its maximum absorbed current (calculated in the worst operating condition), therefore making the power cables and line protection devices less onerous.

All the compressors are fitted as standard with a spare oil heater and a delivery valve.

SOURCE-SIDE HEAT EXCHANGER

Shell-and-tube heat exchanger, with single water passage on tube side. Steel shell, and tube bundle made with copper tubes. The heads can be removed for tube inspection and cleaning. Victaulic couplings on water side (complete with nipple for connection).

USER-SIDE HEAT EXCHANGER

Latest generation shell and tube heat exchanger Hybrid Falling Film with two passes.

The new technology combines the features of a traditional flooded evaporator and the Falling Film evaporator, thus ensuring low approach temperatures and a low refrigerant charge.

Below is a sample cross-section of the evaporator.

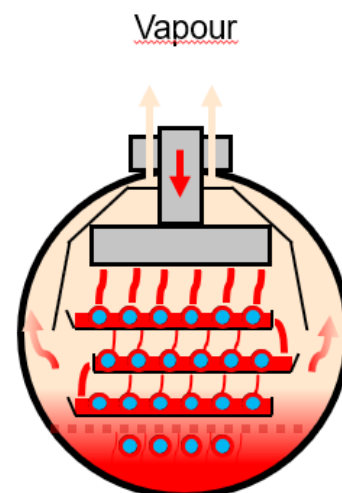

The heat exchanger consists of a steel shell insulated with closed-cell foam material, while the tube bundle is made with copper tubes. The heads can be removed for tube inspection and cleaning. Victaulic couplings on water side (complete with nipple for connection). On the hydraulic connections of the heat exchanger, there are also pipe taps for the differential pressure switch, and wells for the temperature probes.

REFRIGERANT CIRCUIT

The refrigerant circuit of the unit comprises:

- discharge valve for each compressor
- charging valves
- liquid sight glass
- replaceable solid cartridge dehydrator filter on the liquid line;
- a hermetic dehydrator filter on the oil recovery line;
- oil optical level;
- electronic expansion valve
- pressure transducers for reading the high and low pressure values and relevant evaporating and condensing temperatures
- pressure transducer and a temperature probe designed to sense the subcooling value after the condenser;
- a high pressure switch;
- a high and low pressure safety valve;
- an oil separator in the discharge line;
- oil receiver
- jet pumps for oil recovery from the evaporator.
- oil flow switch
- pressure transducer warning about oil return
- sensor warning about low oil level
- sensor warning about low fluid level in evaporator

The suction pipes in the refrigerant circuit and the heat exchanger on the user side are insulated with an extruded closed-cell expanded elastomer.

With reference to the Hybrid Falling Film technology, the refrigerant subcooling value is checked through the measurement of the temperature and pressure downline of the condenser, as shown in the picture below:

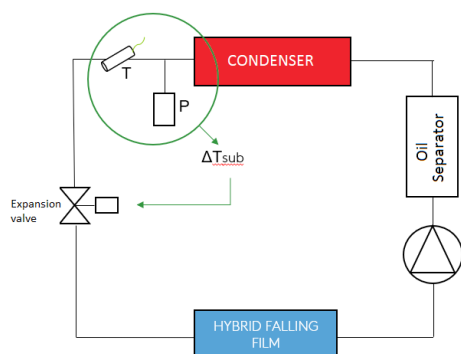

The electronic expansion valve is designed to offer enhanced stability during operation and to maximise the use of evaporation under all load conditions. This also acts as shut-off valve on the liquid line, thereby preventing hazardous refrigerant migrations during compressor stops.

ELECTRICAL CONTROL PANEL

The electrical control panel is made in a painted galvanised sheet-iron box with forced ventilation and IP21 protection rating.

The electrical control panel of the basic unit comprises:

- main disconnect switch
- fuses to protect the compressors and the auxiliary circuits
- compressor contactors
- phase monitor
- potential-free general alarm contacts
- single potential free operating contacts
- microprocessor controller with display accessible from the outside
- Capacitive backup battery for electronic expansion valve
- AC inverter fitted outside the panel

All the electrical cables inside the panel are numbered and the terminal board dedicated to the customer's connections is coloured orange so that it can be quickly identified in the panel.

Standard power supply of the unit is 400V/3~/50Hz

CONTROL BLUETHINK

Programmable microprocessor control, having proprietary control algorithms.

The control allows the following functions:

- Inverter management
- Vi management
- Electronic valve management
- water temperature adjustment, with outgoing water control
- freeze protection
- compressor timings
- recording of the log of all machine inputs, outputs and states
- automatic rotation of compressor starting sequence
- recording of the alarm log
- management of capacity reduction of the compressors during starting, switching off and load tracking
- management of capacity reduction of the compressors in the event of operation outside the limits

Connection resources

The control includes the following connection resources:

- RS485 serial port with Modbus protocol
- Ethernet serial port with Modbus protocol; access to integrated web server
- digital input for remote setting of state (on/off)
- digital input for setting of summer/winter mode (only for HPW version)
- digital input for selection of double set point

By default, the serial connections present as standard are enabled only for reading from BMS. Enabling of writing from BMS is to be requested when ordering.

Main functions of the webserver

As standard, the Bluethink controller integrates a web server with preloaded web page, which is accessed via password and user management on several levels.

The web page allows the following functions to be carried out (some available only for users with advanced level rights):

- display of the main characteristics of the unit such as serial number, size, refrigerant
- display of the general status of the machine: water inlet and outlet temperatures on user side and source side, mode, evaporating and condensing pressures, suction and discharge temperatures
- display of the status of compressors and electronic expansion valves
- display of graphs of the main quantities, as trends in real time and also as log data
- display of alarm log
- remote setting of (on/off)
- remote setting of set point
- remote setting of time band
- remote setting of summer/winter mode

Human-Machine Interface

The control has a graphic display that allows the following information to be displayed:

- water inlet and outlet temperature
- set temperature and differential set points
- description of alarms
- hour meter of operation and number of start-ups of the unit, the compressors and the pumps (if present)
- high and low pressure values, and relevant condensing and evaporating temperatures
- superheating at compressor suction.

For further details on available functions and on displayed information, you can refer to the specific documentation of the control.

CONTROLS AND SAFETY DEVICES

All the units are fitted with the following control and safety components:

- high pressure switch with manual reset for each compressor
- high pressure safety device with automatic reset, for a limited number of occurrences, managed by the controller via specific pressure transducer
- low pressure safety device with automatic reset, for a limited number of occurrences, managed by the controller via specific pressure transducer
- high pressure safety valve
- Low pressure safety valve
- operation probe at the outlet of the user-side heat exchanger that also acts as antifreeze probe
- thermal overload protection for compressors
- water differential pressure switch installed at the factory
- flow switch for oil level detection
- pressure differential on oil filter
- low oil level detection
- low fluid level detection in evaporator

TESTING

All the units are factory-tested and supplied complete with oil and refrigerant.

CERTIFICATIONS AND REFERENCE STANDARDS

The manufacturer has implemented and keeps the Management Systems listed below and it is certified against them:

- Quality Management System according to standard UNI EN ISO 9000;
- Environmental Management System according to standard UNI EN ISO 14000;
- Health and Safety Management System according to standard BS OHSAS 18000 (as converted into UNI EN ISO 45000).

These management systems ensure that the company puts in place any and all actions and initiatives to define and monitor the standards defined by its Management, which are stated in its Quality, Environmental and Safety policies.

To meet the safety requirements, the unit was designed and manufactured in compliance with the directives and product regulations below:

- PED Directive: safety criteria to be followed when designing pressure equipment. Units are PED-approved, cat. IV;
- Machinery Directive: safety criteria to be followed when designing machinery;
- Low Voltage Directive: safety criteria to be followed when designing electrical machine parts;
- Electromagnetic Compatibility Directive: electromagnetic compatibility criteria to be followed when designing electrical machine parts;
- WEEE Directive: criteria for product management at the end of its life cycle as waste with a view to environmental protection.

The units are manufactured, tested and checked with reference to the European standards specified in the Declaration of CE Conformity, in accordance with the requirements and procedures of our Quality System.

Responsibilities and obligations exclusive to the installer:

- to carry out a specific risk assessment according to the European regulations/standards above and/or the local laws in order to define the necessary measures for conformity;
- to comply with the requirements and to take the measures resulting from the outcomes of the risk assessment, pursuant to the relevant regulations and standards.

VERSIONS

Alongside the basic version of the unit, there are the following versions

OH: non-reversible heat pump

This is a heat pump for heating only. Compared to the basic version, both user-side and source-side heat exchangers are insulated.

HPW: reversible heat pump on water side.

This reversible heat pump is suitable for applications in which the user-side circuit and the source-side circuit can be exchanged with each other. Therefore, the fitter must make provision for a system of valves that will allow exchange of the two hydraulic circuits. If the seasonal mode change is carried out via remote signal or BMS, the unit can control motor-driven reversing valves (not supplied) so as to make this operation fully automatic.

Compared to the basic version, both user-side and source-side heat exchangers are insulated.

OPTIONS

/LN: low noise version

The unit includes a soundproofing compartment on the compressor consisting of a rigid outer cowling made of galvanised and painted sheet metal (RAL 7035), lined with sound absorbing matting with high acoustic impedance material in between.

/XLN: super low noise version

The unit includes:

- soundproofing compartment on the compressor consisting of a rigid outer cowling made of galvanised and painted sheet metal (RAL 7035), lined with sound absorbing matting with high acoustic impedance material in between.
- cover jacket on the compressor made of: 50 mm noise-absorbing material made with self-extinguishing polyester fibre on the compressor side - density 30 kg/m³ -, soundproof rubber sheet - density 6 kg/m³ -, placed in-between the polyester layers, and an additional layer of noise-absorbing material made with self-extinguishing polyester fibre on the sheath side - density 30 kg/m³. Total thickness 70 mm
- soundproofing of the delivery and suction piping of the compressor by means of noise-absorbing insulating material and high noise impedance material.

/DC: unit with total recovery condenser

In addition to the basic version, the following elements are included in the chiller unit only:

- a recovery section of condensation heat (100%), featured inside the condenser;
- a temperature probe at the inlet of the heat recovery heat exchanger
- potential free contact in the electrical control panel for activation of heat recovery. When required by the system, through the closing of a contact, the controller automatically manages activation of heat recovery. Heat recovery management is carried out through a control on the temperature of the return water. The controller also automatically manages safety deactivation of heat recovery, if the condensing pressure becomes too high, and switches to using the source-side heat exchanger.

TECHNICAL SPECIFICATIONS

OMEGA SKY Xi

			25.1	29.1	35.1	40.1	47.1	53.1	60.1	72.1	81.1	97.1
R513A												
Cooling												
Refrigeration capacity	(1)	kW	252	304	361	404	459	525	590	718	810	940
Total absorbed power	(1)	kW	52	60	71	79	89	101	113	135	152	181
EER	(1)		4,88	5,06	5,09	5,11	5,16	5,22	5,24	5,32	5,34	5,2
Eurovent efficiency class	(1)		B	A	A	A	A	A	A	A	A	A
ESEER	(10)		7,04	7,24	7,41	7,51	7,6	7,69	7,71	7,66	7,65	7,05
User-side heat exchanger												
Quantity		n°	1	1	1	1	1	1	1	1	1	1
Water flow rate	(1)	m³/h	43	52	62	69	79	90	102	124	139	162
Head loss	(1)	kPa	36	40	38	36	33	34	37	35	33	37
Source-side heat exchanger												
Quantity		n°	1	1	1	1	1	1	1	1	1	1
Water flow rate	(1)	m³/h	52	62	74	83	94	107	120	146	165	192
Head loss	(1)	kPa	23	27	20	18	21	18	18	28	32	34
R134a												
Cooling												
Refrigeration capacity	(1)	kW	258	311	370	413	473	536	603	734	829	952
Total absorbed power	(1)	kW	51	60	70	78	88	101	112	134	151	179
EER	(1)		5,02	5,22	5,25	5,29	5,35	5,33	5,37	5,48	5,5	5,32
Eurovent efficiency class	(1)		B	A	A	A	A	A	A	A	A	A
ISEER	(8)		7,03	7,29	7,3	7,37	7,47	7,45	7,5	7,63	7,6	6,74
IPLV	(9)		8,85	9,18	9,18	9,27	9,39	9,44	9,5	9,53	9,49	8,44
ESEER	(10)		7,24	7,46	7,6	7,73	7,86	7,89	7,93	7,87	7,82	7,14
User-side heat exchanger												
Quantity		n°	1	1	1	1	1	1	1	1	1	1
Water flow rate	(1)	m³/h	44	54	64	71	81	92	104	126	143	164
Head loss	(1)	kPa	39	42	40	38	35	36	39	37	35	37
Source-side heat exchanger												
Quantity		n°	1	1	1	1	1	1	1	1	1	1
Water flow rate	(1)	m³/h	53	63	75	84	96	109	123	149	168	194
Head loss	(1)	kPa	25	28	21	19	22	19	19	30	34	34
Compressors												
Compressors/Circuits		n°/n°	1/1	1/1	1/1	1/1	1/1	1/1	1/1	1/1	1/1	1/1
Minimum capacity reduction step	(3)	%	25%	25%	25%	25%	25%	25%	25%	25%	25%	25%
Refrigerant charge - R134a	(6)	kg	63	65	94	92	95	130	127	155	166	210
Refrigerant charge - R513A	(6)	kg	70	71	105	101	104	144	140	171	180	230
Noise levels												
Sound power lev.	(4)	dB(A)	99	99	100	100	101	101	102	102	104	106
Sound pressure lev.	(5)	dB(A)	81	81	82	82	83	82	83	83	85	87
Sound power levels LN	(4)	dB(A)	94	94	95	95	96	96	97	97	99	101
Sound pressure levels LN	(5)	dB(A)	76	76	77	77	78	77	78	78	80	82
Sound power levels XLN	(4)	dB(A)	91	91	92	92	93	93	94	94	96	98
Sound pressure levels XLN	(5)	dB(A)	73	73	74	74	75	74	75	75	77	79
Dimensions and weights**												
Length		mm	3700	3700	3800	3800	3800	3900	3900	4100	4150	4250
Depth		mm	1500	1500	1550	1550	1550	1550	1550	1670	1670	1850
Height		mm	2050	2050	2100	2100	2100	2150	2150	2300	2400	2400
Operating weight		kg	2215	2335	2694	2832	2987	3381	3509	4260	4742	5460

- (1) Source-side heat exchanger inlet/outlet water temperature 30/35°C; user-side heat exchanger inlet/outlet water temperature 12/7°C. Values compliant with standard EN 14511
- (3) Approximate value. The minimum capacity reached by the unit depends on the operating conditions. The value shown may not be suitable for calculating the minimum volume of water: to do this, consult the "Minimum water content in the system" section.
- (4) Unit operating at nominal operating capacity, without any accessories, with source/side heat exchanger inlet-outlet water temperature 30/35°C and user-side heat exchanger inlet/outlet water temperature 12/7°C. Values obtained from measures taken according to standard ISO 3744 and to the Eurovent certification programme where applicable. Binding values. See NOISE LEVELS section.
- (5) Values obtained from the sound power level (conditions in note 4), related to a distance of 1 m from the unit in free field with directivity factor Q=2. Non-binding values.
- (6) Theoretical values referred to the basic unit (without DC). The amount of gas actually charged in the unit may differ.
- (8) Reference to IS16590:2017, user-side heat exchanger outlet temperature 7 °C. Source-side heat exchanger inlet temperatures : part load 100% - W39°C; part load 75% - W32°C; part load 50% - W26°C; part load 25% - W20°C.
- (9) Reference to AHRI 550/590, user-side heat exchanger outlet temperature 6,7 °C. Source-side heat exchanger inlet temperatures : part load 100% - W 35°C; part load 75% - W 26,7°C; part load 50% - W 18,3°C; part load 25% - W 12,8°C.
- (10) Former Eurovent's seasonal efficiency index. Value not certified by Eurovent from 2019. Reference: base unit, without any accessories

** Basic unit without included accessories

OMEGA SKY Xi HPW (R513A)

			25.1	29.1	35.1	40.1	47.1	53.1	60.1	72.1	81.1
Cooling											
Refrigeration capacity	(1)	kW	252	304	361	404	459	525	590	718	810
Total absorbed power	(1)	kW	52	60	71	79	89	101	113	135	152
EER	(1)		4,88	5,06	5,09	5,11	5,16	5,22	5,24	5,32	5,34
Eurovent efficiency class	(1)		B	A	A	A	A	A	A	A	A
ESEER	(10)		7,04	7,24	7,41	7,51	7,6	7,69	7,71	7,66	7,65
Heating											
Heating capacity	(2)	kW	272	324	386	432	491	558	626	765	862
Total absorbed power	(2)	kW	64	74	88	97	110	123	138	166	186
COP	(2)		4,27	4,39	4,41	4,43	4,47	4,54	4,55	4,62	4,63
Eurovent efficiency class	(2)		B	B	B	B	A	A	A	A	A
Evaporator											
Quantity		n°	1	1	1	1	1	1	1	1	1
Water flow rate	(1)	m³/h	43	52	62	69	79	90	102	124	139
Head loss	(1)	kPa	36	40	38	36	33	34	37	35	33
Water flow rate	(2)	m³/h	60	72	86	97	110	125	141	173	195
Head loss	(2)	kPa	71	78	74	70	64	66	73	69	66
Condenser											
Quantity		n°	1	1	1	1	1	1	1	1	1
Water flow rate	(1)	m³/h	52	62	74	83	94	107	120	146	165
Head loss	(1)	kPa	23	27	20	18	21	18	18	28	32
Water flow rate	(2)	m³/h	47	56	66	74	84	96	108	131	148
Head loss	(2)	kPa	20	23	17	16	18	15	16	24	28
Compressors											
Compressors/Circuits		n°/n°	1/1	1/1	1/1	1/1	1/1	1/1	1/1	1/1	1/1
Minimum capacity reduction step	(3)	%	25%	25%	25%	25%	25%	25%	25%	25%	25%
Refrigerant charge	(7)	kg	70	71	105	101	104	144	140	171	180
Noise levels											
Sound power lev.	(4)	dB(A)	99	99	100	100	101	101	102	102	104
Sound pressure lev.	(5)	dB(A)	81	81	82	82	83	82	83	83	85
Sound power levels LN	(4)	dB(A)	94	94	95	95	96	96	97	97	99
Sound pressure levels LN	(5)	dB(A)	76	76	77	77	78	77	78	78	80
Sound power levels XLN	(4)	dB(A)	91	91	92	92	93	93	94	94	96
Sound pressure levels XLN	(5)	dB(A)	73	73	74	74	75	74	75	75	77
Dimensions and weights**											
Length		mm	3700	3700	3800	3800	3800	3900	3900	4100	4150
Depth		mm	1500	1500	1550	1550	1550	1550	1550	1670	1670
Height		mm	2050	2050	2100	2100	2100	2150	2150	2300	2400
Operating weight		kg	2215	2335	2694	2832	2987	3381	3509	4260	4742

- (1) Source-side heat exchanger inlet/outlet water temperature 30/35°C; user-side heat exchanger inlet/outlet water temperature 12/7°C. Values compliant with standard EN 14511
- (2) Source-side heat exchanger inlet/outlet water temperature 10/7°C; user-side heat exchanger inlet/outlet water temperature 40/45°C. Values compliant with standard EN 14511
- (3) Approximate value. The minimum capacity reached by the unit depends on the operating conditions. The value shown may not be suitable for calculating the minimum volume of water: to do this, consult the "Minimum water content in the system" section.
- (4) Unit operating at nominal operating capacity, without any accessories, with source/side heat exchanger inlet-outlet water temperature 30/35°C and user-side heat exchanger inlet/outlet water temperature 12/7°C. Values obtained from measures taken according to standard ISO 3744 and to the Eurovent certification programme where applicable. Binding values. See NOISE LEVELS section.
- (5) Values obtained from the sound power level (conditions in note 4), related to a distance of 1 m from the unit in free field with directivity factor Q=2. Non-binding values.
- (6) Unit operating at nominal operating capacity, with no options of any kind, with source-side heat exchanger input/output water temperature of 10/7°C and user-side heat exchanger water inlet-outlet temperature of 40/45°C. Values obtained from measurements carried out in accordance with standard ISO 3744.
- (7) Theoretical values referred to the basic unit (without DC). The amount of gas actually charged in the unit may differ.
- (10) Former Eurovent's seasonal efficiency index. Value not certified by Eurovent from 2019. Reference: base unit, without any accessories

** Basic unit without included accessories

OMEGA SKY Xi HPW (R134a)

			25.1	29.1	35.1	40.1	47.1	53.1	60.1	72.1	81.1
Cooling											
Refrigeration capacity	(1)	kW	258	311	370	413	473	536	603	734	829
Total absorbed power	(1)	kW	52	60	70	78	88	101	112	134	151
EER	(1)		5,02	5,22	5,25	5,29	5,35	5,33	5,37	5,48	5,5
ISEER	(8)		7,03	7,29	7,3	7,37	7,47	7,45	7,5	7,63	7,6
IPLV	(9)		8,85	9,18	9,18	9,27	9,39	9,44	9,5	9,53	9,49
ESEER	(10)		7,24	7,46	7,6	7,73	7,86	7,89	7,93	7,87	7,82
Eurovent efficiency class	(1)		B	A	A	A	A	A	A	A	A
Heating											
Heating capacity	(2)	kW	282	336	400	447	510	577	647	792	888
Total absorbed power	(2)	kW	64	74	88	97	110	126	141	165	186
COP	(2)		4,38	4,49	4,52	4,56	4,61	4,52	4,53	4,74	4,74
Eurovent efficiency class	(2)		B	A	A	A	A	A	A	A	A
Evaporator											
Quantity		n°	1	1	1	1	1	1	1	1	1
Water flow rate	(1)	m³/h	44	54	64	71	81	92	104	126	143
Head loss	(1)	kPa	39	42	40	38	35	36	39	37	35
Water flow rate	(2)	m³/h	63	76	90	101	116	130	146	181	203
Head loss	(2)	kPa	78	85	81	76	70	71	77	75	72
Condenser											
Quantity		n°	1	1	1	1	1	1	1	1	1
Water flow rate	(1)	m³/h	53	63	75	84	96	109	123	149	168
Head loss	(1)	kPa	25	28	21	19	22	19	19	30	34
Water flow rate	(2)	m³/h	48	58	69	77	88	99	111	136	153
Head loss	(2)	kPa	21	25	18	17	19	16	17	26	30
Compressors											
Compressors/Circuits		n°/n°	1/1	1/1	1/1	1/1	1/1	1/1	1/1	1/1	1/1
Minimum capacity reduction step	(3)	%	25%	25%	25%	25%	25%	25%	25%	25%	25%
Refrigerant charge	(7)	kg	63	65	94	92	95	130	127	155	166
Noise levels											
Sound power lev.	(4)	dB(A)	99	99	100	100	101	101	102	102	104
Sound pressure lev.	(5)	dB(A)	81	81	82	82	83	82	83	83	85
Sound power levels LN	(4)	dB(A)	94	94	95	95	96	96	97	97	99
Sound pressure levels LN	(5)	dB(A)	76	76	77	77	78	77	78	78	80
Sound power levels XLN	(4)	dB(A)	91	91	92	92	93	93	94	94	96
Sound pressure levels XLN	(5)	dB(A)	73	73	74	74	75	74	75	75	77
Dimensions and weights**											
Length		mm	3700	3700	3800	3800	3800	3900	3900	4100	4150
Depth		mm	1500	1500	1550	1550	1550	1550	1550	1670	1670
Height		mm	2050	2050	2100	2100	2100	2150	2150	2300	2400
Operating weight		kg	2215	2335	2694	2832	2987	3381	3509	4260	4742

- (1) Source-side heat exchanger inlet/outlet water temperature 30/35°C; user-side heat exchanger inlet/outlet water temperature 12/7°C. Values compliant with standard EN 14511
- (2) Source-side heat exchanger inlet/outlet water temperature 10/7°C; user-side heat exchanger inlet/outlet water temperature 40/45°C. Values compliant with standard EN 14511
- (3) Approximate value. The minimum capacity reached by the unit depends on the operating conditions. The value shown may not be suitable for calculating the minimum volume of water: to do this, consult the "Minimum water content in the system" section.
- (4) Unit operating at nominal operating capacity, without any accessories, with source-side heat exchanger inlet-outlet water temperature 30/35°C and user-side heat exchanger inlet/outlet water temperature 12/7°C. Values obtained from measures taken according to standard ISO 3744 and to the Eurovent certification programme where applicable. Binding values. See NOISE LEVELS section.
- (5) Values obtained from the sound power level (conditions in note 4), related to a NOISE distance of 1 m from the unit in free field with directivity factor Q=2. Non-binding values.
- (6) Unit operating at nominal operating capacity, with no options of any kind, with source-side heat exchanger input/output water temperature of 10/7°C and user-side heat exchanger water inlet-outlet temperature of 40/45°C. Values obtained from measurements carried out in accordance with standard ISO 3744.
- (7) Theoretical values referred to the basic unit (without DC). The amount of gas actually charged in the unit may differ.
- (8) Reference to IS16590:2017, user-side heat exchanger outlet temperature 7 °C. Source-side heat exchanger inlet temperatures : part load 100% - W39°C; part load 75% - W32°C; part load 50% - W26°C; part load 25% - W20°C.
- (9) Reference to AHRI 550/590, user-side heat exchanger outlet temperature 6,7 °C. Source-side heat exchanger inlet temperatures : part load 100% - W 35°C; part load 75% - W 26,7°C; part load 50% - W 18,3°C; part load 25% - W 12,8°C.
- (10) Former Eurovent's seasonal efficiency index. Value not certified by Eurovent from 2019. Reference: base unit, without any accessories

** Basic unit without included accessories

OMEGA SKY Xi OH

			25.1	29.1	35.1	40.1	47.1	53.1	60.1	72.1	81.1
R513A											
Heating capacity	(2)	kW	272	324	386	432	491	558	626	765	862
Total absorbed power	(2)	kW	64	74	88	97	110	123	138	166	186
COP	(2)		4,27	4,39	4,41	4,43	4,47	4,54	4,55	4,62	4,63
Eurovent efficiency class	(2)		B	B	B	B	A	A	A	A	A
User-side heat exchanger											
Quantity		n°	1	1	1	1	1	1	1	1	1
Water flow rate	(2)	m³/h	60	72	86	97	110	125	141	173	195
Head loss	(2)	kPa	71	78	74	70	64	66	73	69	66
Source-side heat exchanger											
Quantity		n°	1	1	1	1	1	1	1	1	1
Water flow rate	(2)	m³/h	47	56	66	74	84	96	108	131	148
Head loss	(2)	kPa	20	23	17	16	18	15	16	24	28
R134a											
Heating capacity	(2)	kW	282	336	400	447	510	577	647	792	888
Total absorbed power	(2)	kW	64	74	88	97	110	126	141	165	186
COP	(2)		4,38	4,49	4,52	4,56	4,61	4,52	4,53	4,74	4,74
Eurovent efficiency class	(2)		B	A	A	A	A	A	A	A	A
User-side heat exchanger											
Quantity		n°	1	1	1	1	1	1	1	1	1
Water flow rate	(2)	m³/h	48	58	69	77	88	99	111	136	153
Head loss	(2)	kPa	21	25	18	17	19	16	17	26	30
Source-side heat exchanger											
Quantity		n°	1	1	1	1	1	1	1	1	1
Water flow rate	(2)	m³/h	63	76	90	101	116	130	146	181	203
Head loss	(2)	kPa	78	85	81	76	70	71	77	75	72
Compressors											
Compressors/Circuits		n°/n°	1/1	1/1	1/1	1/1	1/1	1/1	1/1	1/1	1/1
Minimum capacity reduction step	(7)	%	25%	25%	25%	25%	25%	25%	25%	25%	25%
Refrigerant charge - R134a	(6)	kg	63	65	94	92	95	130	127	155	166
Refrigerant charge - R513A	(6)	kg	70	71	105	101	104	144	140	171	180
Noise levels											
Sound power lev.	(4)	dB(A)	99	99	100	100	101	101	102	102	104
Sound pressure lev.	(5)	dB(A)	81	81	82	82	83	82	83	83	85
Sound power levels LN	(4)	dB(A)	94	94	95	95	96	96	97	97	99
Sound pressure levels LN	(5)	dB(A)	76	76	77	77	78	77	78	78	80
Sound power levels XLN	(4)	dB(A)	91	91	92	92	93	93	94	94	96
Sound pressure levels XLN	(5)	dB(A)	73	73	74	74	75	74	75	75	77
Dimensions and weights**											
Length		mm	3700	3700	3800	3800	3800	3900	3900	4100	4150
Depth		mm	1500	1500	1550	1550	1550	1550	1550	1670	1670
Height		mm	2050	2050	2100	2100	2100	2150	2150	2300	2400
Operating weight		kg	2215	2335	2694	2832	2987	3381	3509	4260	4742

(2) Temperature of input-output water to/from source-side heat exchanger 10/7°C; temperature of input-output water to/from user-side heat exchanger 40/45°C. Values compliant with standard EN 14511

(4) Unit operating at nominal operating capacity, with no options of any kind, with source-side heat exchanger input/output water temperature of 10/7°C and user-side heat exchanger water inlet-outlet temperature of 47/55°C. Climate profile Average, with reference to the 2013/813 regulation and the EN 14825 standard.

(5) Values obtained from the sound power level (conditions: note 4), related to a distance of 1 m from the unit in free field with directivity factor Q=2. Non-binding values.

(6) Theoretical values referred to the basic unit (without DC). The amount of gas actually charged in the unit may differ.

(7) Approximate value. The minimum capacity reached by the unit depends on the operating conditions. The value shown may not be suitable for calculating the minimum volume of water: to do this, consult the "Minimum water content in the system" section.

** Basic unit without included accessories

ECODESIGN

INTRODUCTION

The Ecodesign/ErP Directive (2009/125/EC) lays down new standards for more efficient energy use.

The Directive contains various regulations; as regards chiller products and heat pumps, the regulations of interest are the following:

- Regulation 2013/813, for small heat pumps ($P_{design} \leq 400$ kW)
- Regulation 2016/2281, for chillers and heat pumps with $P_{design} > 400$ kW
- Regulation 2013/811, for heat pumps with $P_{design} \leq 70$ kW.

The last-mentioned regulation (2013/811) regards the labelling (Ecolabel certification) of small heat pumps.

The other two regulations (2013/813 and 2016/2281) set seasonal efficiency targets that the products must comply with to be sold and installed in the European Union (essential requirement for CE marking).

These efficiency limits are defined through ratios, which are respectively:

- η_{sh} (SCOP), with reference to regulation 2013/813
- η_{sc} (SEER) for comfort applications and SEPR for process applications, with reference to regulation 2016/2281.

As regards regulation 2016/2281, with effect from 1st January 2021, the required minimum efficiency limit will be raised (Tier 2) from the current threshold (Tier 1).

The figure below schematically illustrates the correspondence between product and reference energy ratio.

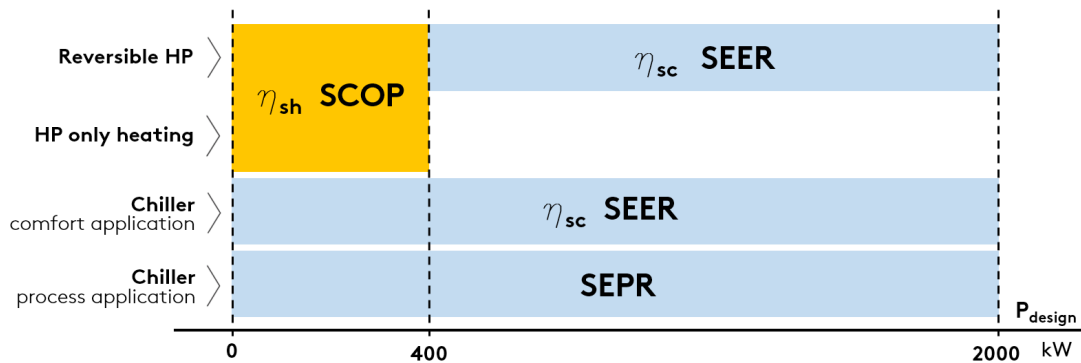

Some notes and clarifications:

For comfort applications, regulation 2016/2281 sets the η_{sc} (SEER) ratio in two different operating conditions:

- SEER calculated with machine inlet/outlet water temperature of 12/7°C (low temperature application),
- SEER calculated with machine inlet/outlet water temperature of 23/18°C (medium temperature application).

The minimum efficiency requirement is the same, but can be met at condition 12/7°C or at condition 23/18°C, depending on the application envisaged for the machine.

Regulation 2013/813 distinguishes two different types: at low temperature and at medium temperature.

The following refer to the application at low temperature: (low temperature application) all heat pumps whose maximum delivery temperature for heating purposes is lower than 52°C with source at temperature of -7°C and -8°C wet bulb (air-water unit) or inlet 10°C (water-water unit), at the reference design conditions for an average climate. For these, the efficiency ratio is "low temperature application" (outlet water temperature 35°C).

For all the other heat pumps, the efficiency ratio is related to "medium temperature application" (outlet water temperature 55°C).

The ratios must be calculated according to the reference European heating season in average climatic conditions.

The minimum efficiency requirements set by the regulations are indicated below.

REGULATION 2016/2281, comfort application

TYPE OF UNIT		MINIMUM REQUIREMENT			
		Tier 1		Tier 2 (2021)	
SOURCE	P _{design}	η_{sc} [%]	SEER	η_{sc} [%]	SEER
air	< 400kW	149	3,8	161	4,1
air	\geq 400kW	161	4,1	179	4,55
water	< 400kW	196	5,1	200	5,2
water	\geq 400kW and < 1500kW	227	5,875	252	6,5
water	\geq 1500kW	245	6,325	272	7

REGULATION 2016/2281, process application

TYPE OF UNIT		MINIMUM REQUIREMENT	
		Tier 1	Tier 2 (2021)
SOURCE	P _{design}	SEPR	SEPR
air	< 400kW	4,5	5
air	\geq 400kW	5	5,5
water	< 400kW	6,5	7
water	\geq 400kW and < 1500kW	7,5	8
water	\geq 1500kW	8	8,5

REGULATION 2013/813

SOURCE	APPLICATION	MINIMUM REQUIREMENT	
		η_{sh} [%]	SCOP
air	low temperature application	125	3,2
water	low temperature application	125	3,325
air	medium temperature application	110	2,825
water	medium temperature application	110	2,95

The conformity of the product must be checked according to the type of application, whether comfort or process, and at the required outlet water temperature.

The two schematic tables below, respectively for comfort application and for process application, indicate the reference of the required conformity according to the type of product and the set point temperature (reference to regulations 2016/2281 and 2013/813).

Important note: for mixed comfort and process applications, the reference application for conformity is the comfort application.

COMFORT APPLICATION

PRODUCT	OUTLET WATER TEMPERATURE	COMPLIANCE INDEX	REGULATION
Chiller	< 18°C	SEER/η _{sc} low temperature application	2016/2281
	≥ 18°C	SEER/η _{sc} medium temperature application	2016/2281
Heat pumps (reversible and only heating) P_{design} ≤ 400kW		SCOP/η _{sh}	2013/813
Reversible heat pumps P_{design} > 400kW	< 18°C	SEER/η _{sc} low temperature application	2016/2281
	≥ 18°C	SEER/η _{sc} medium temperature application	2016/2281
Heat pumps only heating P_{design} > 400kW		-	-

- = exemption from Ecodesign

PROCESS APPLICATION

PRODUCT	OUTLET WATER TEMPERATURE	COMPLIANCE INDEX	REGULATION
Chiller	≥ +2°C , ≤ 12°C	SEPR	2016/2281
	> 12°C	-	-
	> -8°C , < +2°C	-	-

- = exemption from Ecodesign

Some specifications and notes follow.

Partly completed machinery

The term partly completed machinery refers to all units without a user-side or source-side heat exchanger, and therefore to all LC, LE, LC/HP and LE/HP versions. Since these are "non-complete" machines, conformity with Ecodesign depends on combination with the remote heat exchanger.

All the partly completed machinery is CE marked and accompanied by a declaration of conformity. Installation in European Union countries is therefore allowed; correct selection and installation of the remote heat exchanger must be ensured, in accordance with the above cases.

EC fans:

The only option that positively affects the performance of the unit, by increasing its seasonal energy efficiency ratio, is the VEC accessory.

A unit equipped with EC fans has a higher SEER (η_{sc}) than the configuration with standard fans.

RANGE OMEGA SKY Xi

The Ecodesign/ErP Directive (2009/125/EC) lays down new standards for more efficient energy use.

Several regulations are part of the directive, and set mandatory seasonal efficiency targets for sale in the European Union.

The unit therefore, to be CE marked and sold in the EU market, must comply with the minimum requirements imposed by the regulations in question.

Regarding the Omega Sky Xi range, the reference regulations in the various configurations are:

- Regulation 2016/2281, for chillers and heat pumps with $P_{design} > 400$ kW

Minimum efficiency requirements are imposed through seasonal energy efficiency indices, respectively:

- η_{sc} (SEER) for comfort applications
- SEPR for process applications.

As regards the 2016/2281 regulation starting from 1 January 2021, the minimum required efficiency limit will be raised (Tier 2) compared to the current standard (Tier 1).

With reference to the Omega Sky Xi range, below is a list of concerned regulations relating to the different units in their various configurations:

Omega Sky Xi:

- regulation 2016/2281

Omega Sky Xi OH:

- Regulation 2013/813, from size 25.1 to 35.1
- As these are heat pumps for heating applications only with $P_{design} > 400$ kW, sizes from 40.1 onwards are exempt from conformity requirements; All OH units are CE marked.

Omega Sky Xi HPW:

- Regulation 2016/2281, from size 40.1 to 81.1
- Regulation 2013/813, from size 25.1 to 35.1

The tables below give information on the conformity of the units and the seasonal energy performance ratios with regard to the reference regulation.

The tables below give information on the conformity of the units and the seasonal energy performance ratios with regard to the reference regulation.

OMEGA SKY Xi

			25.1	29.1	35.1	40.1	47.1	53.1	60.1	72.1	81.1	97.1
R513A												
REGULATION 2016/2281												
Pdesign	(1)	kW	252	304	361	404	459	525	590	718	810	940
COMFORT												
η _{sc}	(1)	%	280%	290%	300%	307%	317%	316%	317%	316%	316%	288%
SEER	(1)		7,2	7,45	7,7	7,87	8,13	8,09	8,12	8,09	8,1	7,41
Compliance Tier 1	(1)		Y	Y	Y	Y	Y	Y	Y	Y	Y	Y
Compliance Tier 2 (2021)	(1)		Y	Y	Y	Y	Y	Y	Y	Y	Y	Y
PROCESS												
SEPR	(3)		8,28	8,56	8,66	8,74	8,82	9,00	9,04	9,1	9,11	9,16
Compliance Tier 1	(3)		Y	Y	Y	Y	Y	Y	Y	Y	Y	Y
Compliance Tier 2 (2021)	(3)		Y	Y	Y	Y	Y	Y	Y	Y	Y	Y
R134a												
REGULATION 2016/2281												
Pdesign	(1)	kW	258	311	370	413	473	536	603	734	829	952
COMFORT												
η _{sc}	(1)	%	286%	296%	306%	315%	322%	323%	324%	323%	322%	291%
SEER	(1)		7,35	7,6	7,86	8,07	8,24	8,27	8,29	8,28	8,25	7,48
Compliance Tier 1	(1)		Y	Y	Y	Y	Y	Y	Y	Y	Y	Y
Compliance Tier 2 (2021)	(1)		Y	Y	Y	Y	Y	Y	Y	Y	Y	Y
PROCESS												
SEPR	(3)		8,44	8,73	8,83	8,93	9,03	9,23	9,28	9,29	9,27	8,86
Compliance Tier 1	(3)		Y	Y	Y	Y	Y	Y	Y	Y	Y	Y
Compliance Tier 2 (2021)	(3)		Y	Y	Y	Y	Y	Y	Y	Y	Y	Y

Y = unit in compliance with Ecodesign at the indicated condition.

N = unit not in compliance with Ecodesign at the given condition: it can be installed only in non-EU countries.

(1) User-side heat exchanger water inlet/outlet temperature 12/7°C (low temperature application), with reference to regulation 2016/2281 and standard EN 14825.

(3) User-side heat exchanger water inlet/outlet temperature 12/7°C, with reference to regulation 2016/2281 and norm EN 14825.

OMEGA SKY Xi HPW

			40.1	47.1	53.1	60.1	72.1	81.1
R513A								
REGULATION 2016/2281								
Pdesign	(1)	kW	404	459	525	590	718	810
COMFORT								
η _{sc}	(1)	%	307%	317%	316%	317%	316%	316%
SEER	(1)		7,87	8,13	8,09	8,12	8,09	8,1
Compliance Tier 1	(1)		Y	Y	Y	Y	Y	Y
Compliance Tier 2 (2021)	(1)		Y	Y	Y	Y	Y	Y
PROCESS								
SEPR	(3)		8,74	8,82	9,00	9,04	9,1	9,11
Compliance Tier 1	(3)		Y	Y	Y	Y	Y	Y
Compliance Tier 2 (2021)	(3)		Y	Y	Y	Y	Y	Y
R134a								
REGULATION 2016/2281								
Pdesign	(1)	kW	413	473	536	603	734	829
COMFORT								
η _{sc}	(1)	%	315%	322%	323%	324%	323%	322%
SEER	(1)		8,07	8,24	8,27	8,29	8,28	8,25
Compliance Tier 1	(1)		Y	Y	Y	Y	Y	Y
Compliance Tier 2 (2021)	(1)		Y	Y	Y	Y	Y	Y
PROCESS								
SEPR	(3)		8,93	9,03	9,23	9,28	9,29	9,27
Compliance	(3)		Y	Y	Y	Y	Y	Y
Compliance Tier 2 (2021)	(3)		Y	Y	Y	Y	Y	Y

Y = unit in compliance with Ecodesign at the indicated condition.

N = unit not in compliance with Ecodesign at the given condition: it can be installed only in non-EU countries.

(1) User-side heat exchanger water inlet/outlet temperature 12/7°C (low temperature application), with reference to regulation 2016/2281 and standard EN 14825.

(3) User-side heat exchanger water inlet/outlet temperature 12/7°C, with reference to regulation 2016/2281 and norm EN 14825.

OMEGA SKY Xi HPW

				25.1	29.1	35.1
R513A						
REGULATION 2013/813						
Pdesign	(1)	kW	271	322	384	
η_{sh}	(1)	%	165%	169%	172%	
SCOP	(1)		4,32	4,44	4,49	
Compliance	(1)		Y	Y	Y	
R134a						
Pdesign	(1)	kW	278	330	393	
η_{sh}	(1)	%	168%	173%	175%	
SCOP	(1)		4,4	4,52	4,58	
Compliance	(1)		Y	Y	Y	

Y = unit in compliance with Ecodesign at the indicated condition.

N = unit not in compliance with Ecodesign at the given condition: it can be installed only in non-EU countries.

(1) User-side heat exchanger water inlet/outlet temperature 47/55°C (SCOP MT), Average climate profile, with reference to regulation 2013/813 and norm EN 14825.

OMEGA SKY Xi OH

				25.1	29.1	35.1
R513A						
REGULATION 2013/813						
Pdesign	(1)	kW	271	322	384	
η_{sh}	(1)	%	165%	169%	172%	
SCOP	(1)		4,32	4,44	4,49	
Compliance	(1)		Y	Y	Y	
R134a						
Pdesign	(1)	kW	278	330	393	
η_{sh}	(1)	%	168%	173%	175%	
SCOP	(1)		4,4	4,52	4,58	
Compliance	(1)		Y	Y	Y	

Y = unit in compliance with Ecodesign at the indicated condition.

N = unit not in compliance with Ecodesign at the given condition: it can be installed only in non-EU countries.

(1) User-side heat exchanger water inlet/outlet temperature 47/55°C (SCOP MT), Average climate profile, with reference to regulation 2013/813 and norm EN 14825.

INSTALLATION ADVICE

The units described in this document are, by nature, strongly affected by the characteristics of the system, the working conditions and the installation site.

Remember that the unit must be installed by a qualified and skilled technician, and in compliance with the national legislation in force in the destination country.

The installation must be done in such a way that it will be possible to carry out all routine and non-routine maintenance operations.

Before starting any work, you must carefully read the "Installation, operation and maintenance manual" of the machine and do the necessary safety checks to prevent any malfunctioning or hazards.

We give some advice below that will allow you to increase the efficiency and reliability of the unit and therefore of the system into which it is inserted.

Water characteristics

To preserve the life of the exchangers, the water is required to comply with some quality parameters and it is therefore necessary to make sure its values fall within the ranges indicated in the following table:

Total hardness	2,0 ÷ 6,0 °f
Langelier index	- 0,4 ÷ 0,4
pH	7,5 ÷ 8,5
Electrical conductivity	10 ÷ 500 µS/cm
Organic elements	-
Hydrogen carbonate (HCO₃⁻)	70 ÷ 300 ppm
Sulphates (SO₄²⁻)	< 50 ppm
Hydrogen carbonate / Sulphates (HCO₃⁻/SO₄²⁻)	> 1
Chlorides (Cl⁻)	< 50 ppm
Nitrates (NO₃⁻)	< 50 ppm
Hydrogen sulphide (H₂S)	< 0,05 ppm
Ammonia (NH₃)	< 0,05 ppm
Sulphites (SO₃), free chlorine (Cl₂)	< 1 ppm
Carbon dioxide (CO₂)	< 5 ppm
Metal cations	< 0,2 ppm
Manganese ions (Mn⁺⁺)	< 0,2 ppm
Iron ions (Fe²⁺ , Fe³⁺)	< 0,2 ppm
Iron + Manganese	< 0,4 ppm
Phosphates (PO₄³⁻)	< 2 ppm
Oxygen	< 0,1 ppm

Installation of water filters on all the hydraulic circuits is obligatory.

The supply of the most suitable filters for the unit can be requested as accessory. In this case, the filters are supplied loose and must be installed by the customer following the instructions given in the installation, operation and maintenance manual.

Glycol mixtures

With temperatures below 5°C, it is mandatory to work with water and anti-freeze mixtures, and also change the safety devices (anti-freeze, etc.), which must be carried out by qualified authorised personnel or by the manufacturer.

Liquid outlet temperature or minimum ambient temperature	°C	0	-5	-10	-15	-20	-25	-30	-35	-40
Freezing point	°C	-5	-10	-15	-20	-25	-30	-35	-40	-45
Ethylene glycol	%	6	22	30	36	41	46	50	53	56
Propylene glycol	%	15	25	33	39	44	48	51	54	57

The quantity of antifreeze should be considered as % on weight

Minimum water content in the system

For correct operation of the unit, it is necessary to ensure a buffering on the system such as to comply with the minimum operating time considering the greater between the minimum OFF time and the minimum ON time. In short, these contribute to limiting the number of times the compressors are switched on per hour and to preventing undesired deviations from the set point of the delivered water temperature.

Larger amounts of water are in any case always preferable, because they allow a smaller number of starts and switch-offs of the compressors, less wear of them and an increase in the efficiency of the system as a consequence of a reduction in the number of transients.

$$V_{min} = \frac{P_{tot} \cdot 1.000}{N} \cdot \frac{300}{\Delta T \cdot \rho \cdot c_p} + P_{tot} \cdot 0,8$$

where

V_{min} is the minimum water content of the system [l]

P_{tot} is the total cooling capacity of the machine [kW]

N: number of capacity reduction steps

ΔT : differential allowed on the water temperature. Unless otherwise specified, this value is considered to be 2.5K

ρ : density of the heat-carrying fluid. Unless otherwise specified, the density of water is considered

c_p : specific heat of the heat-carrying fluid. Unless otherwise specified, the specific heat of water is considered

Considering the use of water and grouping together some terms, the formula can be re-written as follows:

$$V_{min} = \frac{P_{tot}}{N} \cdot 28,66 + P_{tot} \cdot 0,8$$

For the N values, consider the following convention:

- for units with 1 compressor N = 4

Installation site

To determine the best installation site for the unit and its orientation, you should pay attention to the following points:

- compliance with the clearance spaces indicated in the official dimensional drawing of the unit must be guaranteed so as to ensure accessibility for routine and non-routine maintenance operations
- you should consider the origin of the hydraulic pipes and their diameters because these affect the radiuses of curvature and therefore the spaces needed for installing them
- you should consider the position of the cable inlet on the electrical control panel of the unit as regards the origin of the power supply
- if the installation includes several units side by side, you should consider the position and dimensions of the manifolds of the heat exchangers

Once the best position for the unit has been identified, you must check that the support slab has the following characteristics:

- its dimensions must be proportionate to those of the unit: if possible, longer and wider than the unit by at least 30 cm and 15/20cm higher than the surrounding surface
- it must be able to bear at least 4 times the operating weight of the unit
- must allow the unit to be installed in a level position

The units are designed and built to reduce to a minimum the level of vibration transmitted to the ground, but it is in any case advisable to use rubber or spring anti-vibration mounts, which are available as accessory and should be requested when ordering.

The anti-vibration mounts must be fixed to the machine before positioning the unit on the ground.



Swegon Operations s.r.l.

Via Valletta, 5 - 30010

Cantarana di Cona, (VE) Italy - T. +39 0426 921111 - F. +39 0426 302222

www.blueboxcooling.com - info@bluebox.it

Swegon Operations s.r.l. a socio unico - P.IVA 02481290282

Company directed and coordinated by Investment Latour (Sweden)

