

Omega Sky

436÷1564 kW



General

Indoor water-condensed liquid chiller with semi-hermetic screw compressors, flooded shell-and-tube condenser and dry-expansion shell-and-tube evaporator.

Configurations

HPW: reversible heat pump version on water side

OH: non-reversible heat pump version

LC: motoevaporating execution

/LN: low-noise unit

/XLN: super low-noise unit

/DC: execution with recovery condenser

Strengths

- ▶ High efficiency at partial loads: ESEER up to 6,38
- ▶ No-glycol Free-Cooling Management (option)
- ▶ Non-flammable refrigerant R513A, with GWP=573
- ▶ Reduced refrigerant charge
- ▶ Easy handling: depth ≤ 900 mm for single-compressor sizes
- ▶ Hot water production up to 63°C
- ▶ BlueThink advanced control with integrated web server. Multilogic function and Blueeye® supervision system. (options)

BlueBox 
by Swegon

Omega Sky

Description of accessories	6
Refrigerant	6
Refrigerant circuit accessories	6
Hydraulic circuit accessories	8
Electrical accessories	9
Other accessories	16
Technical specifications	18
Omega Sky OH	20
Omega Sky HPW	22
Omega Sky LC	26
Ecodesign	28
Electrical specifications	34
Omega Sky LC	37
Flow rate ranges of heat exchangers	38
Operating limits	39
Omega Sky	39
Omega Sky OH	40
Omega Sky HPW	41
Omega Sky LC	42
Noise levels	43
Dimensional diagrams	47
Omega Sky LC	62
Installation advice	65
Water characteristics	65
Glycol mixtures	65
Minimum water content in the system	66
Installation site	67



Omega Sky

Indoor water-condensed liquid chiller with semi-hermetic screw compressors, flooded shell-and-tube condenser and dry-expansion shell-and-tube evaporator.

REFRIGERANT

Refrigerant R513A (GWP=573*) standard.

The refrigerant consists in a blend of R134a (44%) and R1234yf (56%), with temperature glide equal to 0.

R513A is classified as a non hazardous fluid (Group 2 fluid under PED).

It is also included in Class A1 under the ASHRAE Standard 34:

- non-toxic;
- non-flammable.

These characteristics make R513A ideal for indoor installations.

The excellent GWP value may be an advantage in projects where:

- min. targets are adopted for the containment of the environmental footprint;
- it is possible to receive incentives or other benefits that are applicable in some countries or are connected to specific plant design criteria.

This also goes to the benefit of unit installation, commissioning and maintenance as it reduces the overall management costs.

STRUCTURE

Consists of polyester powder coated hot dip galvanised sheet steel profiles (RAL 9005).

The electrical control panel is made in a polyester powder-coated hot dip galvanised sheet steel box (RAL 7035).

Units from 43.1 to 159.2 are approved PED III category

COMPRESSORS

Semi-hermetic screw compressors with continuous capacity reduction of output capacity by 25 up to 100%, with high energy efficiency especially in cooling applications.

The capacity reduction of the entire unit is always continuous, from the minimum capacity reduction step, based on the number of compressors, up to 100%.

difference between delivery and suction.

All the compressors are fitted with check valve on delivery side, metal mesh filter on suction side and electronic protection with temperature sensors directly inserted in the windings and on the delivery pipe.

The machine is started and switched off with a forced 25% capacity reduction of each compressor and starting is of the "star-delta" type.

All the compressors are supplied as standard with a crankcase heater and a delivery valve. They are installed on anti-vibration mounts in order to reduce vibration transmission to the structure.

SOURCE-SIDE HEAT EXCHANGER

Flooded shell-and-tube heat exchanger, with single water passage on tube side.

Depending on size, the model consists of 1 or 2 condensers.

Steel shell, and tube bundle made with copper tubes.

The heads can be removed for tube inspection and cleaning.

Victaulic couplings on water side (complete with nipple for connection).

USER-SIDE HEAT EXCHANGER

Dry-expansion shell-and-tube heat exchanger.

Sized to maximize the efficiency of the unit, by keeping the overall dimensions and the refrigerant charge down to a minimum.

The heat exchanger consists of a steel shell insulated with closed-cell foam material, while the tube bundle is made with copper tubes.

The heads can be removed for tube inspection and cleaning.

Victaulic couplings on water side (complete with nipple for connection).

On the hydraulic connections of the heat exchanger, there are also pipe taps for the differential pressure switch, and wells for the temperature probes.

REFRIGERANT CIRCUIT

The model consists of sizes with 1 or 2 refrigerant circuits, each equipped with compressor.

Each refrigerant circuit of the unit comprises:

- discharge valve for each compressor
- shut-off valve in the liquid line
- charging valves
- liquid sight glass
- replaceable solid cartridge dehydrator filter
- electronic expansion valve
- pressure transducers for reading the high and low pressure values and relevant evaporating and condensing temperatures
- pressostato di alta pressione
- a safety valve.

The pipes of the refrigerant circuit and the heat exchanger on the user side are insulated with extruded closed-cell expanded elastomer.

Compared to the mechanical expansion valve, the electronic expansion valve allows machine stability to be reached more quickly and better superheating control to maximize the use of the evaporator in all load conditions. This also acts as shut-off valve on the liquid line, thereby preventing hazardous refrigerant migrations during compressor stops.

ELECTRICAL CONTROL PANEL

The electrical control panel is made in a painted galvanised sheet-iron box with forced ventilation and IP21 protection rating.

The electrical control panel of the basic unit comprises:

- main disconnect switch
- fuses to protect the compressors and the auxiliary circuits
- compressor contactors
- phase monitor
- potential-free general alarm contacts
- single potential free operating contacts
- microprocessor controller with display accessible from the outside
- Capacitive backup battery for electronic expansion valve

All the electrical cables inside the panel are numbered and the terminal board dedicated to the customer's connections is coloured orange so that it can be quickly identified in the panel.

Standard power supply of the unit is 400V/3~/50Hz

CONTROL BLUETHINK

Programmable microprocessor control, having proprietary control algorithms.

The control allows the following functions:

- water temperature adjustment, with outgoing water control
- freeze protection
- compressor timings
- automatic rotation of compressor starting sequence
- recording of the log of all machine inputs, outputs and states
- automatic rotation of compressor starting sequence
- recording of the alarm log
- management of capacity reduction of the compressors during starting, switching off and load tracking
- management of capacity reduction of the compressors in the event of operation outside the limits

Connection resources

The control includes the following connection resources:

- RS485 serial port with Modbus protocol
- Ethernet serial port with Modbus protocol; access to integrated web server
- digital input for remote setting of state (on/off)
- digital input for setting of summer/winter mode (only for HPW version)
- digital input for selection of double set point

By default, the serial connections present as standard are enabled only for reading from BMS. Enabling of writing from BMS is to be requested when ordering.

Main functions of the webserver

As standard, the Bluethink controller integrates a web server with preloaded web page, which is accessed via password and user management on several levels.

The web page allows the following functions to be carried out (some available only for users with advanced level rights):

- display of the main characteristics of the unit such as serial number, size, refrigerant
- display of the general status of the machine: water inlet and outlet temperatures on user side and source side, mode, evaporating and condensing pressures, suction and discharge temperatures
- display of the status of compressors and electronic expansion valves
- display of graphs of the main quantities, as trends in real time and also as log data
- display of alarm log
- remote setting of (on/off)
- remote setting of set point
- remote setting of time band
- remote setting of summer/winter mode

Human-Machine Interface

The control has a graphic display that allows the following information to be displayed:

- water inlet and outlet temperature
- set temperature and differential set points
- description of alarms
- hour meter of operation and number of start-ups of the unit, the compressors and the pumps (if present)
- high and low pressure values, and relevant condensing and evaporating temperatures
- superheating at compressor suction.

For further details on available functions and on displayed information, you can refer to the specific documentation of the control.

CONTROLS AND SAFETY DEVICES

All the units are fitted with the following control and safety components:

- double high pressure switch with manual reset for each compressor
- high pressure safety device with automatic reset, for a limited number of occurrences, managed by the controller via specific pressure transducer
- low pressure safety device with automatic reset, for a limited number of occurrences, managed by the controller via specific pressure transducer
- high pressure safety valve
- Low pressure safety valve (standard for units 143.2 and 159.2)
- operation probe at the outlet of the user-side heat exchanger that also acts as antifreeze probe
- thermal overload protection for compressors
- water differential pressure switch installed at the factory

TESTING

All the units are factory-tested and supplied complete with oil and refrigerant.

CERTIFICATIONS AND REFERENCE STANDARDS

The manufacturer has implemented and keeps the Management Systems listed below and it is certified against them:

- Quality Management System according to standard UNI EN ISO 9000;
- Environmental Management System according to standard UNI EN ISO 14000;
- Health and Safety Management System according to standard BS OHSAS 18000 (as converted into UNI EN ISO 45000).

These management systems ensure that the company puts in place any and all actions and initiatives to define and monitor the standards defined by its Management, which are stated in its Quality, Environmental and Safety policies.

To meet the safety requirements, the unit was designed and manufactured in compliance with the directives and product regulations below:

- PED Directive: safety criteria to be followed when designing pressure equipment. Units from 43.1 to 159.2 are approved PED III category

- Machinery Directive: safety criteria to be followed when designing machinery;
- Low Voltage Directive: safety criteria to be followed when designing electrical machine parts;
- Electromagnetic Compatibility Directive: electromagnetic compatibility criteria to be followed when designing electrical machine parts;
- WEEE Directive: criteria for product management at the end of its life cycle as waste with a view to environmental protection.

The units are manufactured, tested and checked with reference to the European standards specified in the Declaration of CE Conformity, in accordance with the requirements and procedures of our Quality System.

Responsibilities and obligations exclusive to the installer:

- to carry out a specific risk assessment according to the European regulations/standards above and/or the local laws in order to define the necessary measures for conformity;
- to comply with the requirements and to take the measures resulting from the outcomes of the risk assessment, pursuant to the relevant regulations and standards.

VERSIONS

Alongside the basic version of the unit, there are the following versions

OH: non-reversible heat pump

This is a heat pump for heating only. Compared to the basic version, both user-side and source-side heat exchangers are insulated.

The units are equipped with a compressor specifically selected for the production of water up to 63 ° C.

HPW: reversible heat pump on water side.

This reversible heat pump is suitable for applications in which the user-side circuit and the source-side circuit can be exchanged with each other. Therefore, the fitter must make provision for a system of valves that will allow exchange of the two hydraulic circuits. If the seasonal mode change is carried out via remote signal or BMS, the unit can control motor-driven reversing valves (not supplied) so as to make this operation fully automatic.

Compared to the basic version, both user-side and source-side heat exchangers are insulated.

LC: condenserless unit

The unit does not have a source-side water heat exchanger so that it can be connected to a remote condenser.

Compared to the basic version, the unit is supplied:

- with weld-on refrigerant connections closed with copper plugs
- without refrigerant charge and charged with nitrogen
- with safety valves supplied

The LC/DC version, complete with total heat recovery heat exchanger for each circuit, also includes an installed liquid receiver and safety valves in the machine.

Compared to the basic version, the unit is supplied:

- with 3-way valve installed

OPTIONS

/LN: low noise version

The unit includes a soundproofing compartment on the compressor consisting of a rigid outer cowling made of galvanised and painted sheet metal (RAL 7035), lined with sound absorbing matting with high acoustic impedance material in between.

/XLN: super low noise version

The unit includes:

- soundproofing compartment on the compressor consisting of a rigid outer cowling made of galvanised and painted sheet metal (RAL 7035), lined with sound absorbing matting with high acoustic impedance material in between.
- jacket on each compressor made of removable sound absorbing material.

/DC: unit with total recovery condenser

In addition to the basic set-up (chiller unit), the following are included:

- for each condenser, a section for recovering 100% of the condensation heat on each refrigerant circuit.
- a temperature probe at the inlet of each heat recovery heat exchanger
- potential free contact in the electrical control panel for activation of heat recovery. When required by the system, through the closing of a contact, the controller automatically manages activation of heat recovery. Heat recovery management is carried out through a control on the temperature of the return water. The controller also automatically manages safety deactivation of heat recovery, if the condensing pressure becomes too high, and switches to using the source-side heat exchanger.

DESCRIPTION OF ACCESSORIES

Some accessories may be incompatible with each other even if not expressly indicated.

Refrigerant

R134 R134a

Unit supplied with refrigerant R134a instead of R513A. Does not apply to LC versions.

Refrigerant circuit accessories

BC Capacitive backup battery for electronic expansion valve

When the compressors stop, the controller always closes the electronic expansion valve to prevent dangerous refrigerant migration. The presence of the backup battery ensures that the electronic valve is kept in closed position even when there is no power supply

This option uses a condenser as energy storage, and not an ordinary coil. In this way, it is not affected by the memory effect of normal coils and the need for maintenance is avoided.

BK Brine Kit

This accessory is compulsory if a water temperature set point lower than or equal to +3°C is used (if the unit is provided with double set point or variable set point, the lower set point is considered).

The accessory consists of increased insulation and suitable sizing and calibration of some components.

The inlet and outlet temperatures of the user-side exchanger must be given on ordering to allow correct setting of the alarm parameters and verification of the sizing of the expansion valve.

The cooling set point can then be changed by the customer in an interval that, compared to the set point given on ordering, ranges from -1K up to the allowed limit temperature.

The unit will be optimized to work at the set point temperature given on ordering. For different set points, the cooling capacity provided and the level of efficiency of the machine could decrease and move away from these conditions.

This accessory obligatorily requires insertion of one of the condensation control options.

DVS Double safety valve

With this accessory, instead of each individual safety valve per circuit, there is a "candelabrum" with two safety valves and a diverter valve for choosing the valve in operation. This allows the safety valves to be replaced without having to drain the machine and without having to stop it.

Accessory installed in the machine for all versions (chiller, heat pump, LC/DC) excepting the LC version for which it is supplied with the unit.

MAFR Pressure gauges

The operating pressures of each circuit of the unit can be displayed on the control by accessing the relevant screens. Also, the machine can be fitted with pressure gauges (two for each circuit) installed in a clearly visible position. These allow reading in real time of the working pressures of the refrigerant gas on the low pressure side and on the high pressure side of each refrigerant circuit.

RIC Liquid receiver

The adoption of this accessory always guarantees correct feeding of the expansion valve even when the unit is subjected to wide external air temperature ranges.

Accessory supplied with the unit only for LC units, with the exception of the LC/DC version.

For the LC/DC version, the receivers are already included and installed at the factory.

RPP Refrigerant leak detector with automatic pump down

This accessory includes a refrigerant leak detector. Detection of a refrigerant leak is managed by the controller through a specific alarm and display of a specific icon on the display of the controller. For all the circuits of the unit, the alarm also starts the machine stopping procedure with pump down, confining all the refrigerant in the condenser.

Accessory as an alternative to Refrigerant leak detector.

-
- RPR Refrigerant leak detector**
This accessory includes a refrigerant leak detector. Detection of a refrigerant leak is managed by the controller through a specific alarm and display of a specific icon on the display of the controller. This alarm stops the unit. Accessory as an alternative to Refrigerant leak detector with automatic pump down.
- RUBA Compressor suction valves**
The valves situated on the suction side of the compressors allow the compressor to be isolated from the rest of the refrigerant circuit, so making the maintenance operations quicker and less invasive.
The compressor discharge valve is standard on all compressors
- SCU Cumulative 0-10V signal for condensation control**
This accessory requires a 0-10V output in the terminal board to carry out condensation control through a device outside the machine (2-way valve, 3-way valve, inverter-controlled pump). The signal is linked to the condensing pressure.
The signal is cumulative and therefore the accessory is suitable for combination on units in which there is a single condensation control device located on the common branch of the source.
Incompatible with condensation control with modulating valve.
- SIN Independent 0-10V signals for condensation control**
For each refrigerant circuit, this accessory requires a 0-10V output in the terminal board to carry out condensation control through a device outside the machine (2-way valve, 3-way valve, inverter-controlled pump). The signal is linked to the condensing pressure.
There is a signal for each refrigerant circuit and therefore the accessory is suitable for combination on units in which the sources of each circuit are managed independently.
Incompatible with condensation control with modulating valve.
- VM2 Condensation control with 2-way modulating valve**
The accessory includes the supply of a 2-way modulating valve complete with servo control to be installed on the source-side hydraulic circuit (installation by the customer). The servo control is controlled via a 0-10V signal from the control depending on the condensing pressure.
This accessory is to be used in applications where it is beneficial, when possible, to reduce the total flow rate of water coming from the source (for example, when well water is used). When the unit reaches the setpoint, the valve will be forced to close.
Accessory supplied loose.
- VM3 Condensation control with 3-way modulating valve**
The accessory includes the supply of a 3-way modulating valve complete with servo control to be installed on the source-side hydraulic circuit (installation by the customer). The servo control is controlled via a 0-10V signal from the control depending on the condensing pressure.
This accessory is to be used in applications where it is beneficial, when possible, to reduce the flow rate of water sent to the source-side heat exchanger (for example, when water from a loop is used). When the unit reaches the set point, the valve will be forced to total recirculation.
Accessory supplied loose.
- VS Liquid line solenoid valve**
This accessory prevents refrigerant migration that could damage the compressor on starting.
As standard on HPW and OH units.

Hydraulic circuit accessories

CFC Flanged hydraulic connections + counterflanges

Depending on the version of the unit, flanges and counterflanges are supplied for:

- user side
- on the source side.
- recovery side

Accessory supplied loose.

CISL Hydraulic connections on same side

This accessory makes it possible to have the condenser connections on the same side as the evaporator connections. Weld-on connections.

For units with 1 condenser, the accessory consists of bends and couplings at the inlet and outlet of the condenser; for units with 2 condensers, the accessory consists of manifolds to join up the connections of the condensers at both inlet and outlet.

In the case of the DC version, connections for the relevant hydraulic circuit are included.

For LC/DC units, the connections refer to heat recovery only.

Accessory supplied loose.

KFC FC/NG kit

The kit is available only for the basic model (chiller).

This option includes "FC/NG management"

It consists of a module, supplied separately in a separate package.

The module carries out the free-cooling mode without using glycol. The mode is managed by the BlueThink controller of the main chiller unit.

The kit is fully panelled with epoxy polyester powder coated sheet metal (RAL 7035) and lined with matting made of sound absorbing and soundproofing material.

The kit comprises:

- a water-water heat exchanger: brazed AISI stainless steel plate heat exchanger with anti-condensation insulation made of closed-cell insulating material. The heat exchanger makes the separation between the source side (glycol) and the user side (non-glycol) and allows transfer of cooling capacity from one side to the other during operation in free cooling mode.
- a 3-way modulating valve: the valve, complete with servo control, allows the free cooling circuit to be fed and the condensation control to be carried out when the unit is working in mixed chiller / free cooling mode.
- an inverter-controlled source-side pump: the inverter allows the water flow rate to be modulated on the source side in order to carry out condensation control or control of output capacity at the free cooling heat exchanger.

The kit must be hydraulically and electrically connected to the main chiller unit; operation to be carried out on site by the customer.

PVX Variable flow setup for HYZER X

The dedicated HYZER X controller is designed to manage the different units, devices and components that make up a hydronic system.

Systems featuring this controller require that the PVX option be installed at the ends of the user-side heat exchanger of a differential pressure transducer so that the machine is set up for variable flow rate control.

This option is mandatory in all units making up the system.

For additional information on the product HYZER X, please refer to the specific technical catalogue.

VIX Shut-off valves for systems with external pumps for HYZER X

Systems featuring the HYZER X controller enable the selection of the shut-off valve used in systems that have an external pumping unit.

Two shut-off valves are supplied together with water/water machines that need to be installed on the source- and user-side circuits of the unit (installation by customer).

FLMX User-side flow meter for HYZER X

Systems featuring the HYZER X controller enable the selection of the flow meter option to calculate the flow rate and the performances of the units.

The option is supplied with the system for installation on the user side (installation by customer).

Electrical accessories

A41 Power supply 415/3/50

A43 Power supply 400/3/50

The standard power supply of the unit

CP Single potential free operating contacts

For units fitted with this accessory, there are clean contacts available on the terminal board inside the electrical box from which the customer can acquire signals that show the status of the unit's components (compressors, fans, pumps, alarms).

CSP Set point compensation depending on external air temperature

For units fitted with this accessory, the set point of the unit is set so that it can vary between two values, a maximum and a minimum, depending on the external air temperature. The compensation ramp and the maximum and minimum values of the set point can be changed by the user.

Unless otherwise specified in the order, the controller will be set to implement a positive compensation logic according to the temperatures shown in the following diagrams:

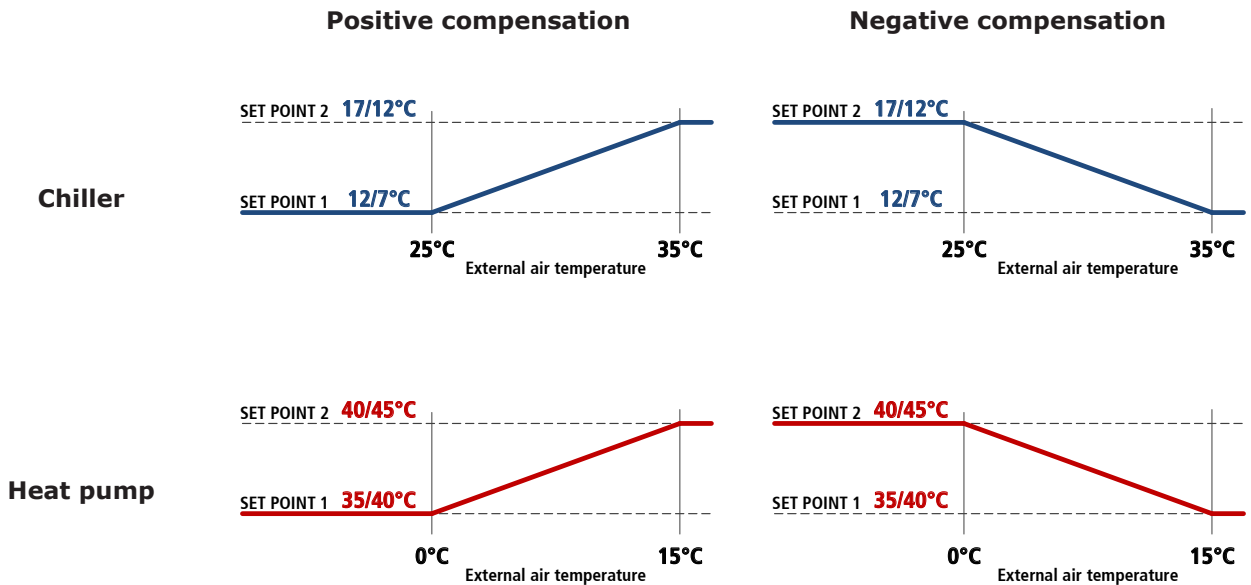

DAA Double power supply with automatic switching

A motor-driven automatic switch to which to connect two separate power supply lines (for example, one from the mains power line and one from the uninterruptible power supply unit) is installed in the electrical control panel of the unit.

The switching from one line to another is automatic and obligatorily requires passing through the OFF position. When this accessory is requested, the power supply of the unit must compulsorily include neutral.

DAM Double power supply with manual switching

A manual switch to which to connect two separate power supply lines (for example, one from the mains power line and one from the uninterruptible power supply unit) is installed in the electrical control panel of the unit. The switching from one line to another is manual and obligatorily requires passing through the OFF position.

ENM Energy meter

The accessory allows the main electrical quantities (including voltage, current, power) to be read on the three phases, via current transformer.

This accessory communicates with the BlueThink controller to supervise the monitored data. The values measured are then made available through the unit display and the web server.

FARE Fast Restart

The Fast Restart accessory enables the controller to carry out a fast restart of the unit following a blackout, in order to reduce machine down times to a minimum.

This accessory requires the provision of a power supply line dedicated to the controller (uninterruptible power supply unit installed by the customer) and a maximum and minimum voltage relay in the electrical control panel. In this way, the controller of the unit will always remain powered even during a blackout.

Once the main power supply returns after a blackout, the starting of the first compressor takes place within 60 seconds and the full capacity of the unit is reached in about 180 seconds (a time that depends on the number of compressors and the instant load level).

In order to protect component service life, the controller may carry out the Fast Restart procedure no more than 3 times in an hour and 5 times in one day.

Also, to make it easier to carry out any maintenance on the power supply line dedicated to the controller, there is a selector switch inside the electrical control panel to allow the controller to be powered directly from the main power supply of the machine.

Includes "Maximum and minimum voltage relay".

GFC FC/NG management

This option is available only for the basic model (chiller).

The option includes configuration of the BlueThink controller of the unit, in order to carry out the free-cooling mode, without using glycol.

The option also includes integration in the machine of: free-cooling pump relay, consent for external dry cooler, system return probe and dry-cooler inlet and outlet probes.

The components required for making the system, and also the hydraulic and electrical connections to the unit, are to be provided by the customer.

More specifically, the system will consist of:

- a water-water heat exchanger that carries out the separation between the source side (glycol) and the user side (non-glycol).
- a 3-way modulating valve that feeds the free cooling circuit and carries out condensation control when the unit is working in mixed chiller/free cooling mode.
- a source-side pump

IA Automatic circuit breakers (instead of fuses)

This accessory requires the installation of automatic circuit breakers, instead of fuses, for the protection of auxiliary loads. Also, the same accessory uses automatic circuit breakers with adjustable thermal overload protection to protect the compressors.

LIID Limitation of the current absorbed by digital input

When this accessory is requested, a digital input is prepared in the terminal board to activate the forced capacity reduction of the unit to a set fixed level.

This accessory is useful when there is a need to necessarily limit the power absorbed by the unit as regards particular conditions.

We point out that, in some conditions (for example, during hourly compressor rotation procedures), the controller could force the unit to operate at full capacity for limited periods of time.

****non tradotto** **non tradotto****

non tradotto

non tradotto

non tradotto

-
- R1PR Relay for management of 1 external heat recovery-side pump**
This accessory can be requested for units without heat recovery pumps (for DC units) and allows a pump outside the machine to be controlled.
- R2PU Relay for management of 2 external user-side pumps**
This accessory can be requested for units without user-side pumps and allows two pumps outside the machine to be controlled with a running/stand-by logic by implementing a rotation on the hours of operation.
The two pumps are controlled by two separate relays.
- R2PR Relay for management of 2 external heat recovery-side pumps**
This accessory can be requested for units without heat recovery pumps (for DC units) and allows two pumps outside the machine to be controlled with a running/stand-by logic by implementing a rotation on the hours of operation.
The two pumps are controlled by two separate relays.
- R2PU Relay for management of 2 external user-side pumps**
This accessory can be requested for units without user-side pumps and allows two pumps outside the machine to be controlled with a running/stand-by logic by implementing a rotation on the hours of operation.
The two pumps are controlled by two separate relays.
- RE1S Relay for management of 1 external source-side pump**
This accessory can be requested for units without source-side pumps and allows a pump outside the machine to be controlled.
Does not apply to LC units.
- RE2S Relay for management of 2 external source-side pumps**
This accessory can be requested for units without source-side pumps and allows two pumps outside the machine to be controlled with a running/stand-by logic by implementing a rotation on the hours of operation. Does not apply to LC units.
The two pumps are controlled by two separate relays.
- RIF Power factor correction to $\cos\phi \geq 0.95$**
With this accessory, an electrical control panel (IP54 protection rating), containing power factor correction capacitors to make the $\cos\phi$ of the unit greater than or equal to 0.95, is supplied with the unit. The capacitors should be connected (by the customer) to the electrical control panel of the unit in the specially prepared terminal board.
Besides reducing the absorbed reactive power, the use of this accessory also allows the maximum absorbed current to be lowered.
- RMMT Maximum and minimum voltage relay**
This accessory constantly monitors the voltage value and the unit's power supply phase sequence. If the supply voltage does not fall within the set parameters or there is a phase reversal, an alarm is generated that stops the machine to prevent damage to its main parts
- SETD Double set point from digital input**
The accessory allows you to preset two different operating set points and manage the change from one to the other through a digital signal.
The set point temperatures must be specified when ordering. For optimization of the unit, reference will be made to the lower set point in chiller mode and the higher set point in heat pump mode.
Unless otherwise specified in the order, the controller will be set at the factory with the following temperatures:
- in chiller mode, set point 1 to 7°C and set point 2 to 12°C
 - in heat pump mode (only for HPW and OH units) set point 1 at 45°C and set point 2 at 40°C
- SETV Variable set point with remote signal**
The accessory allows the set point to be varied continuously between two preset values, a maximum and a minimum, depending on an external signal that can be of the 0-1V, 0-10V or 4-20mA type.
The set point temperatures and the type of signal to use for the adjustment must be specified when ordering. For optimization of the unit, reference will be made to the lower set point in chiller mode and the higher set point in heat pump mode.
Unless otherwise specified in the order, the controller will be set at the factory with 0-10V analogue input and with the following temperatures:
- in chiller mode, 0V will correspond to a set point of 7°C and 10V will correspond to a set point of 12°C
 - in heat pump mode (only for HPW and OH units), 0V will correspond to a set point of 45°C and 10V will correspond to a set point of 40°C

SOFT Electronic soft-starter

Screw compressors (excluding inverter-controlled ones) are switched on using star-delta starting since this method allows very small effective average inrush currents to be obtained, but, as can be seen in the following diagrams, the connection change generates current peaks lasting a few ms.

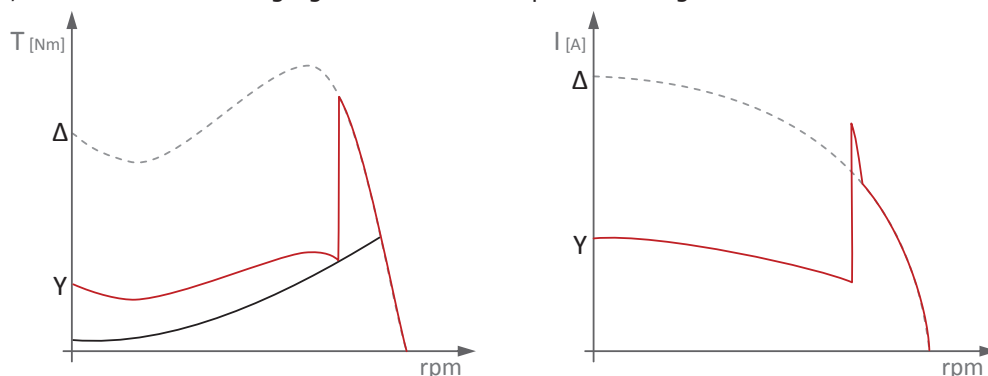

If the unit is equipped with the electronic soft-starter accessory, the starting of each compressor becomes of the DOL (Direct On Line) type and therefore with a higher effective average inrush current, but with an acceleration ramp that allows elimination of the peaks that would be generated when changing from star to delta.

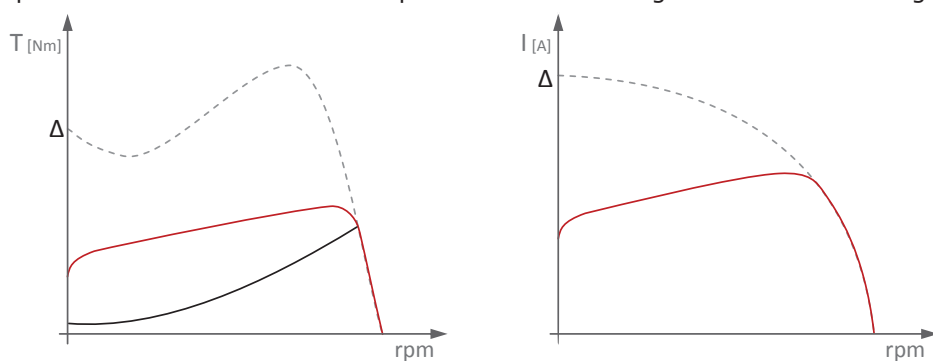

TERM Remote-controlled user terminal panel

This accessory allows the terminal normally situated on the machine to be replicated on a support situated at a distance. It is particularly suitable when the unit is placed in an area that is not easily accessible.

The accessory is supplied loose and is to be installed by the customer at a maximum distance of 120m from the unit. We advise using a cable of the following type: "TECO O.R. FE 2x2xAWG24 SN/ST/PUR".

For this accessory, there is a dedicated serial port.

FMx Multilogic Function

The Multilogic function allows management of up to 32 units equipped with advanced Bluethink controller and connected in hydraulic parallel with each other.

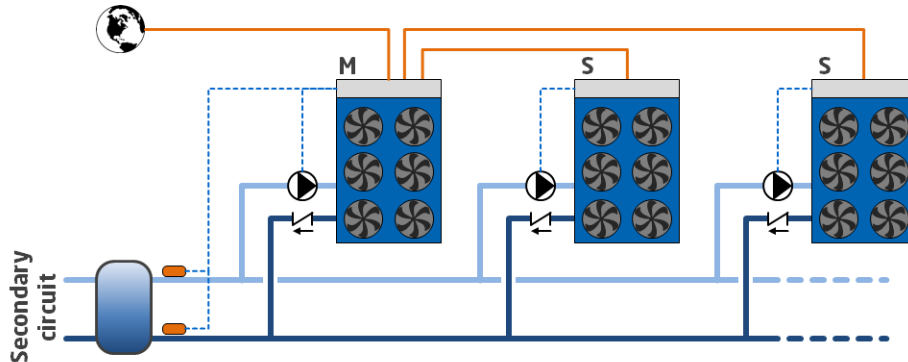

On the basis of the information recorded by the temperature probes installed on the delivery and return manifolds of the system, with the master unit, a capacity request is generated that is distributed among the units connected in the Multilogic network according to settable priority and optimization logics.

If communication between the units fails or if the master is off-line, the slave units can continue to work according to the set thermoregulation parameters.

The connected units can be different from each other, in terms of capacity and set-up, provided the following rules are complied with:

- if there are both chiller units and heat pumps in the Multilogic network, the Master unit must obligatorily be one of the HP units
- if there are both free cooling and non free-cooling units in the Multilogic network, the Master unit must obligatorily be one of the free-cooling units.

The Multilogic function that can be requested with the unit can be:

- **FM0:** Multilogic function for Slave unit
- **FM2:** Multilogic function for Master unit for managing up to 2 Slaves
- **FM6:** Multilogic function for Master unit for managing up to 6 Slaves

If you need to connect more than 6 slaves (up to 31), you can ask for a quotation from our sales department.

For the slave units, the accessory requires:

- programming of the unit as slave of a system of machines in Multilogic network

For the master units, the accessory requires:

- programming of the unit as master of a system of machines in Multilogic network
- entering of the parameters necessary for connection with the individual slave units
- installation in the electrical control panel of a network switch to allow the units to be connected in a LAN network.
- the supply of 2 temperature probes to be positioned on the delivery and return manifold of the system (supplied separately with it, installation and wiring by the customer)

The connection between the master unit and the slave units made with a CAT cable. 5E/UTP (prepared by the customer) with RJ45 connectors. Maximum cable length 100m.

For further details, please refer to the controller manual.

-
- GLO Modbus Lonworks Gateway**
With this accessory, a RS485/Lon gateway is installed inside the electrical control panel.
By default, the programming gives read-only access to the control of the unit. Reading / writing access is active on field with a service level.
- PBA BACnet protocol over IP (Ethernet)**
The controller is set for use, in read and write mode, of the BACnet port on IP protocol.
By default, the programming gives read-only access to the control of the unit. Reading / writing access is active on field with a service level.
- PSN SNMP protocol**
The accessory consists of a gateway that allows Ethernet connection to a SNMP manager supervision system.
The use of this accessory causes the RS485 serial port to be unavailable.
- SERI RS485 serial interface with Modbus protocol**
RS485 serial interface with Modbus protocol.
- SMAR Smartlink function predisposition**
This accessory makes it possible to connect the controller of the unit with the controller of a Swegon GOLD™ air handling unit via a simple serial cable, so allowing their operating logics to be merged into a single consciousness that pursues the maximum energy efficiency of the system. The RS485 serial interface is already included and dedicated to connection with Swegon units.
The option is incompatible with:
- double set point
 - variable set point with remote signal
 - summer/winter selection by digital input
 - set point compensation depending on external air temperature
 - multilogic
 - all communication protocols.
- SW4P Network switch with 4 ports**
The accessory includes installation in DIN rail of a professional 4-port network switch. Requires Blueye via Ethernet.
- SW8P Network switch with 8 ports**
The accessory includes installation in DIN rail of a professional 8-port network switch.
Requires Blueye via Ethernet.
- WIFI Wi-Fi**
The accessory includes the supply of a Hot Spot WiFi already installed, wired and configured, complete with antenna. This accessory requires the Ethernet port of the controller to be available or, alternatively, a network switch with at least one available port to be present in the machine.

Other accessories

AG Rubber anti-vibration mounts

These allow you to reduce the vibrations transmitted from the unit to the surface it is standing on. Accessory supplied loose.

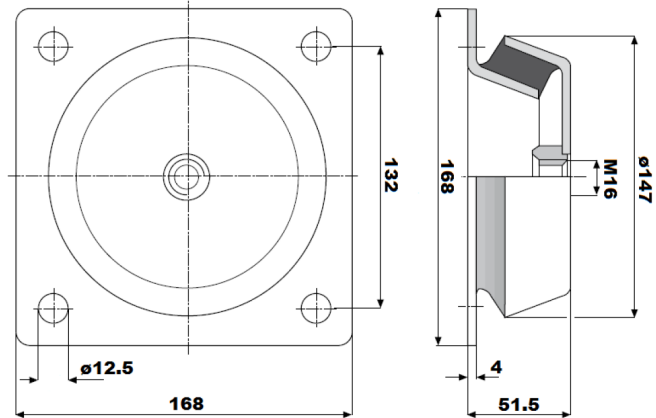

AM Spring anti-vibration mounts

These allow you to reduce the vibrations transmitted from the unit to the surface it is standing on. Accessory supplied loose.

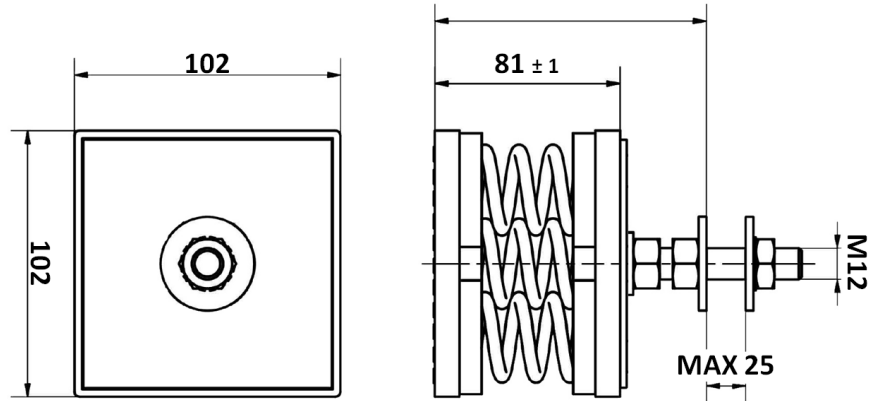

FLUS Flow switch

As an alternative to the differential pressure switch (standard flow sensor), it is possible to request the paddle flow switch as accessory. This detects when there is no water flow to the user-side exchanger and sends a signal to the control of the unit that will stop the compressors to prevent damage to the exchangers. The flow switch is supplied loose (installation by the customer) and replaces the water differential pressure switch (standard).

GABB Packaging in wooden crate

The unit is protected by a custom-made wooden cage, including a wooden sled designed for loading into containers and a fixing system. The accessory can be used for container shipping. Loading on containers must be carried out at the factory. The accessory is incompatible with "Skid for shipping in containers".

KFW Water filter kit

To protect the elements of the hydraulic circuit (in particular, the exchangers), there are Y filters that can stop and settle the particles that are normally present in the water flow and would otherwise settle in the more delicate parts of the hydraulic circuit and damage its heat exchange capacity.

The kit involves the supply of a filter for each exchanger present in the machine.

Installation of the water filter is mandatory even when it is not supplied as an accessory.

Accessory supplied loose.

Depending on the version of the unit, user side and source side filters are supplied, and for DC version units, heat recovery side filters are also supplied.

PREA Unit suitable to be disassembled on site

The unit is delivered so that it can be disassembled easily on site if this makes the installation operations easier.

A unit requested with this option is supplied:

- screwed instead of riveted
- with plugged and not welded pipes
- without refrigerant charge
- untested
- covered by the warranty only if reassembled and screwed together by personnel authorized by the factory

SLCO Skid for shipping in container

The accessory provides for the installation of a wooden sled for loading and a fixing system inside the container by a strap. The accessory must be used for shipping in container. Loading on containers must be carried out at the factory. The accessory is incompatible with "Packaging in wooden crate".

TECHNICAL SPECIFICATIONS

OMEGA SKY

			43.1	50.1	58.1	66.1	70.1	79.1	63.2
R513A									
Cooling									
Refrigeration capacity	(1)	kW	437	502	574	651	710	783	635
Total absorbed power	(1)	kW	87	98	110	124	140	156	124
EER	(1)		5,04	5,13	5,24	5,23	5,08	5,03	5,11
Eurovent efficiency class	(1)		B	A	A	A	A	B	A
ESEER	(10)		6,11	6,1	6,23	6,17	6,05	5,97	6,15
User-side heat exchanger									
Quantity		n°	1	1	1	1	1	1	1
Water flow rate	(1)	m³/h	75	86	99	112	122	135	109
Head loss	(1)	kPa	30	33	25	34	26	29	32
Source-side heat exchanger									
Quantity		n°	1	1	1	1	1	1	2
Water flow rate	(1)	m³/h	90	103	117	133	146	161	130
Head loss	(1)	kPa	43	41	42	39	43	50	42
R134a									
Cooling									
Refrigeration capacity	(1)	kW	431	496	567	642	699	774	626
Total absorbed power	(1)	kW	83	94	105	119	134	150	119
EER	(1)		5,19	5,27	5,38	5,38	5,2	5,17	5,25
Eurovent efficiency class	(1)		A	A	A	A	A	A	A
ISEER	(8)		-	-	-	-	-	-	-
IPLV	(9)		7,02	7,05	7,25	7,26	7,23	6,88	7,1
ESEER	(10)		6,13	6,13	6,35	6,28	6,2	6,21	6,35
User-side heat exchanger									
Quantity		n°	1	1	1	1	1	1	1
Water flow rate	(1)	m³/h	74	85	98	111	120	133	108
Head loss	(1)	kPa	29	31	24	32	25	27	31
Source-side heat exchanger									
Quantity		n°	1	1	1	1	1	1	2
Water flow rate	(1)	m³/h	88	101	115	130	143	158	128
Head loss	(1)	kPa	40	39	40	37	40	48	39
Compressors									
Compressors/Circuits		n°/n°	1/1	1/1	1/1	1/1	1/1	1/1	2/2
Minimum capacity reduction step	(3)	%	25%	25%	25%	25%	25%	25%	12,5%
Refrigerant charge	(6)	kg	74	73	71	68	69	71	91
Noise levels									
Sound power lev.	(4)	dB(A)	91	91	92	93	94	95	94
Sound pressure lev.	(5)	dB(A)	73	72	74	75	76	77	75
Sound power levels LN	(4)	dB(A)	86	86	87	88	89	90	89
Sound pressure levels LN	(5)	dB(A)	68	67	69	70	71	72	70
Sound power levels XLN	(4)	dB(A)	83	83	84	85	86	87	86
Sound pressure levels XLN	(5)	dB(A)	65	64	66	67	68	69	67
Dimensions and weights**									
Length		mm	4127	4671	4172	4175	4175	4455	4308
Depth		mm	900	900	900	900	900	900	1345
Height		mm	1950	1950	1988	1988	1996	1996	1842
Operating weight		kg	2879	2952	3255	3298	3379	3457	4058

- (1) Source-side heat exchanger inlet/outlet water temperature 30/35°C; user-side heat exchanger inlet/outlet water temperature 12/7°C. Values compliant with standard EN 14511
- (3) Approximate value. The minimum capacity reached by the unit depends on the operating conditions. The value shown may not be suitable for calculating the minimum volume of water: to do this, consult the "Minimum water content in the system" section.
- (4) Unit operating at nominal operating capacity, without any accessories, with source/side heat exchanger inlet-outlet water temperature 30/35°C and user-side heat exchanger inlet/outlet water temperature 12/7°C. Values obtained from measures taken according to standard ISO 3744 and to the Eurovent certification programme where applicable. Binding values. See NOISE LEVELS section.
- (5) Values obtained from the sound power level (conditions in note 4), related to a distance of 1 m from the unit in free field with directivity factor Q=2. Non-binding values.
- (6) Theoretical values referred to the basic unit (without DC). The amount of gas actually charged in the unit may differ.
- (8) Reference to IS16590:2017, user-side heat exchanger outlet temperature 7 °C. Source-side heat exchanger inlet temperatures : part load 100% - W39°C; part load 75% - W32°C; part load 50% - W26°C; part load 25% - W20°C.
- (9) Reference to AHRI 550/590, user-side heat exchanger outlet temperature 6,7 °C. Source-side heat exchanger inlet temperatures : part load 100% - W 35°C; part load 75% - W 26,7°C; part load 50% - W 18,3°C; part load 25% - W 12,8°C.
- (10) Former Eurovent's seasonal efficiency index. Value not certified by Eurovent from 2019. Reference: base unit, without any accessories

** Basic unit without included accessories

OMEGA SKY

			72.2	88.2	101.2	116.2	132.2	143.2	159.2
R513A									
Cooling									
Refrigeration capacity	(1)	kW	722	872	1006	1160	1319	1421	1500
Total absorbed power	(1)	kW	141	173	195	220	250	279	311
EER	(1)		5,12	5,05	5,16	5,27	5,28	5,1	4,83
Eurovent efficiency class	(1)		A	B	A	A	A	A	B
ESEER	(10)		6,18	6	6,13	6,34	6,25	6,16	6,34
User-side heat exchanger									
Quantity		n°	1	1	1	1	1	1	1
Water flow rate	(1)	m³/h	124	150	173	200	227	245	270
Head loss	(1)	kPa	27	33	31	45	47	28	31
Source-side heat exchanger									
Quantity		n°	2	2	2	2	2	2	2
Water flow rate	(1)	m³/h	148	179	206	236	269	291	321
Head loss	(1)	kPa	43	42	42	43	40	43	50
R134a									
Cooling									
Refrigeration capacity	(1)	kW	712	860	993	1144	1303	1400	1500
Total absorbed power	(1)	kW	136	166	187	212	240	268	299
EER	(1)		5,24	5,19	5,3	5,4	5,43	5,22	5,02
Eurovent efficiency class	(1)		A	A	A	A	A	A	A
ISEER	(8)		-	-	-	-	-	-	-
IPLV	(9)		7,08	6,87	6,98	7,23	7,28	7,09	7,19
ESEER	(10)		6,37	6,15	6,29	6,37	6,43	6,35	6,35
User-side heat exchanger									
Quantity		n°	1	1	1	1	1	1	1
Water flow rate	(1)	m³/h	123	148	171	197	224	241	266
Head loss	(1)	kPa	26	31	29	43	45	27	29
Source-side heat exchanger									
Quantity		n°	2	2	2	2	2	2	2
Water flow rate	(1)	m³/h	145	176	202	232	264	286	316
Head loss	(1)	kPa	40	40	39	41	38	40	48
Compressors									
Compressors/Circuits		n°/n°	2/2	2/2	2/2	2/2	2/2	2/2	2/2
Minimum capacity reduction step	(3)	%	12,5%	12,5%	12,5%	12,5%	12,5%	12,5%	12,5%
Refrigerant charge	(6)	kg	90	148	144	139	136	132	136
Noise levels									
Sound power lev.	(4)	dB(A)	94	94	94	95	96	97	98
Sound pressure lev.	(5)	dB(A)	75	75	75	76	77	78	79
Sound power levels LN	(4)	dB(A)	89	89	89	90	91	92	93
Sound pressure levels LN	(5)	dB(A)	70	70	70	71	72	73	74
Sound power levels XLN	(4)	dB(A)	86	86	86	87	88	89	90
Sound pressure levels XLN	(5)	dB(A)	67	67	67	68	69	70	71
Dimensions and weights**									
Length		mm	4308	5227	5188	4869	4860	5316	5166
Depth		mm	1345	1345	1350	1345	1345	1345	1350
Height		mm	1842	1928	2232	2004	2004	2004	2232
Operating weight		kg	4137	5330	5684	5816	6148	6962	7156

- (1) Source-side heat exchanger inlet/outlet water temperature 30/35°C; user-side heat exchanger inlet/outlet water temperature 12/7°C. Values compliant with standard EN 14511
- (3) Approximate value. The minimum capacity reached by the unit depends on the operating conditions. The value shown may not be suitable for calculating the minimum volume of water: to do this, consult the "Minimum water content in the system" section.
- (4) Unit operating at nominal operating capacity, without any accessories, with source/side heat exchanger inlet-outlet water temperature 30/35°C and user-side heat exchanger inlet/outlet water temperature 12/7°C. Values obtained from measures taken according to standard ISO 3744 and to the Eurovent certification programme where applicable. Binding values. See NOISE LEVELS section.
- (5) Values obtained from the sound power level (conditions in note 4), related to a distance of 1 m from the unit in free field with directivity factor Q=2. Non-binding values.
- (6) Theoretical values referred to the basic unit (without DC). The amount of gas actually charged in the unit may differ.
- (8) Reference to IS16590:2017, user-side heat exchanger outlet temperature 7 °C. Source-side heat exchanger inlet temperatures : part load 100% - W39°C; part load 75% - W32°C; part load 50% - W26°C; part load 25% - W20°C.
- (9) Reference to AHRI 550/590, user-side heat exchanger outlet temperature 6,7 °C. Source-side heat exchanger inlet temperatures : part load 100% - W 35°C; part load 75% - W 26,7°C; part load 50% - W 18,3°C; part load 25% - W 12,8°C.
- (10) Former Eurovent's seasonal efficiency index. Value not certified by Eurovent from 2019. Reference: base unit, without any accessories

** Basic unit without included accessories

OMEGA SKY OH

			43.1	50.1	58.1	66.1	70.1	79.1	63.2
R513A									
Heating capacity	(2)	kW	470	544	618	704	775	840	701
Total absorbed power	(2)	kW	107	122	135	155	175	190	162
COP	(2)		4,4	4,46	4,57	4,56	4,42	4,43	4,32
Eurovent efficiency class	(2)		B	A	A	A	B	A	B
User-side heat exchanger									
Quantity		n°	1	1	1	1	1	1	2
Water flow rate	(2)	m³/h	81	94	106	121	133	144	121
Head loss	(2)	kPa	27	27	24	30	35	42	28
Source-side heat exchanger									
Quantity		n°	1	1	1	1	1	1	1
Water flow rate	(2)	m³/h	105	122	139	159	173	188	156
Head loss	(2)	kPa	52	58	45	63	48	54	57
R134a									
Heating capacity	(2)	kW	466	539	601	690	781	839	692
Total absorbed power	(2)	kW	102	118	129	148	173	188	155
COP	(2)		4,57	4,59	4,65	4,66	4,51	4,47	4,46
Eurovent efficiency class	(2)		A	A	A	A	A	A	A
User-side heat exchanger									
Quantity		n°	1	1	1	1	1	1	2
Water flow rate	(2)	m³/h	80	93	103	119	134	144	119
Head loss	(2)	kPa	23	28	24	30	36	42	30
Source-side heat exchanger									
Quantity		n°	1	1	1	1	1	1	1
Water flow rate	(2)	m³/h	105	122	136	157	176	188	155
Head loss	(2)	kPa	53	61	47	64	49	53	64
Compressors									
Compressors/Circuits		n°/n°	1/1	1/1	1/1	1/1	1/1	1/1	2/2
Minimum capacity reduction step	(7)	%	25%	25%	25%	25%	25%	25%	12,5%
Refrigerant charge	(6)	kg	74	73	71	68	69	71	91
Noise levels									
Sound power lev.	(8)	dB(A)	96	96	97	98	99	99	98
Sound pressure lev.	(5)	dB(A)	78	77	79	80	81	81	79
Sound power levels LN	(8)	dB(A)	91	91	92	93	94	94	93
Sound pressure levels LN	(5)	dB(A)	73	72	74	75	76	76	74
Sound power levels XLN	(8)	dB(A)	88	88	89	90	91	91	90
Sound pressure levels XLN	(5)	dB(A)	70	69	71	72	73	73	71
Dimensions and weights**									
Length		mm	4127	4671	4172	4175	4175	4455	4308
Depth		mm	900	900	900	900	900	900	1345
Height		mm	1950	1950	1988	1988	1996	1996	1842
Operating weight		kg	2879	2952	3255	3298	3379	3457	4058

(2) Temperature of input-output water to/from source-side heat exchanger 10/7°C; temperature of input-output water to/from user-side heat exchanger 40/45°C. Values compliant with standard EN 14511

(4) Unit operating at nominal operating capacity, with no options of any kind, with source-side heat exchanger input/output water temperature of 10/7°C and user-side heat exchanger water inlet-outlet temperature of 40/45°C. Values obtained from measurements carried out in accordance with standard ISO 3744.

(5) Values obtained from the sound power level (condition in note 8), referred to a distance of 1 m from the unit in free field with directivity factor Q = 2. Non-binding values.

(6) Theoretical values referred to the basic unit (without DC). The amount of gas actually charged in the unit may differ.

(7) Approximate value. The minimum capacity reached by the unit depends on the operating conditions. The value shown may not be suitable for calculating the minimum volume of water: to do this, consult the "Minimum water content in the system" section.

(8) User-side heat exchanger water inlet/outlet temperature 47/55°C (SCOP MT), Average climate profile, with reference to regulation 2013/813 and norm EN 14825.

** Basic unit without included accessories

OMEGA SKY OH

			72.2	88.2	101.2	116.2	132.2	143.2	159.2
R513A									
Heating capacity	(2)	kW	801	940	1085	1233	1417	1551	1673
Total absorbed power	(2)	kW	183	212	243	273	311	350	378
COP	(2)		4,37	4,43	4,47	4,51	4,56	4,43	4,42
Eurovent efficiency class	(2)		B	A	A	A	A	A	A
User-side heat exchanger									
Quantity		n°	2	2	2	2	2	2	2
Water flow rate	(2)	m³/h	138	162	186	212	244	267	288
Head loss	(2)	kPa	28	26	27	24	30	35	42
Source-side heat exchanger									
Quantity		n°	1	1	1	1	1	1	1
Water flow rate	(2)	m³/h	179	210	243	278	321	347	375
Head loss	(2)	kPa	50	58	54	82	86	51	57
R134a									
Heating capacity	(2)	kW	798	930	1073	1205	1385	1565	1675
Total absorbed power	(2)	kW	175	204	234	262	298	346	375
COP	(2)		4,57	4,57	4,58	4,6	4,65	4,52	4,46
Eurovent efficiency class	(2)		A	A	A	A	A	A	A
User-side heat exchanger									
Quantity		n°	2	2	2	2	2	2	2
Water flow rate	(2)	m³/h	137	160	184	207	238	269	288
Head loss	(2)	kPa	28	23	28	25	31	36	42
Source-side heat exchanger									
Quantity		n°	1	1	1	1	1	1	1
Water flow rate	(2)	m³/h	180	210	242	273	315	352	376
Head loss	(2)	kPa	52	60	57	84	89	53	57
Compressors									
Compressors/Circuits		n°/n°	2/2	2/2	2/2	2/2	2/2	2/2	2/2
Minimum capacity reduction step	(7)	%	12,5%	12,5%	12,5%	12,5%	12,5%	12,5%	12,5%
Refrigerant charge	(6)	kg	90	148	144	139	136	132	136
Noise levels									
Sound power lev.	(8)	dB(A)	98	99	99	100	101	102	102
Sound pressure lev.	(5)	dB(A)	79	80	80	81	82	83	83
Sound power levels LN	(8)	dB(A)	93	94	94	95	96	97	97
Sound pressure levels LN	(5)	dB(A)	74	75	75	76	77	78	78
Sound power levels XLN	(8)	dB(A)	90	91	91	92	93	94	94
Sound pressure levels XLN	(5)	dB(A)	71	72	72	73	74	75	75
Dimensions and weights**									
Length		mm	4308	5227	5188	4869	4860	5316	5166
Depth		mm	1345	1345	1350	1345	1345	1345	1350
Height		mm	1842	1928	2232	2004	2004	2004	2232
Operating weight		kg	4137	5330	5684	5816	6148	6962	7156

(2) Temperature of input-output water to/from source-side heat exchanger 10/7°C; temperature of input-output water to/from user-side heat exchanger 40/45°C. Values compliant with standard EN 14511

(4) Unit operating at nominal operating capacity, with no options of any kind, with source-side heat exchanger input/output water temperature of 10/7°C and user-side heat exchanger water inlet-outlet temperature of 40/45°C. Values obtained from measurements carried out in accordance with standard ISO 3744.

(5) Values obtained from the sound power level (condition in note 8), referred to a distance of 1 m from the unit in free field with directivity factor Q = 2. Non-binding values.

(6) Theoretical values referred to the basic unit (without DC). The amount of gas actually charged in the unit may differ.

(7) Approximate value. The minimum capacity reached by the unit depends on the operating conditions. The value shown may not be suitable for calculating the minimum volume of water: to do this, consult the "Minimum water content in the system" section.

(8) User-side heat exchanger water inlet/outlet temperature 47/55°C (SCOP MT), Average climate profile, with reference to regulation 2013/813 and norm EN 14825.

** Basic unit without included accessories

OMEGA SKY HPW (R513A)

			43.1	50.1	58.1	66.1	70.1	79.1	63.2
Cooling									
Refrigeration capacity	(1)	kW	437	502	574	651	710	783	635
Total absorbed power	(1)	kW	87	98	110	124	140	156	124
EER	(1)		5,04	5,13	5,24	5,23	5,08	5,03	5,11
Eurovent efficiency class	(1)		B	A	A	A	A	B	A
ESEER	(10)		6,11	6,1	6,23	6,17	6,05	5,97	6,15
Heating									
Heating capacity	(2)	kW	506	568	641	729	792	886	718
Total absorbed power	(2)	kW	108	122	137	156	173	193	157
COP	(2)		4,67	4,65	4,68	4,68	4,58	4,6	4,56
Eurovent efficiency class	(2)		A	A	A	A	A	A	A
Evaporator									
Quantity		n°	1	1	1	1	1	1	1
Water flow rate	(1)	m³/h	75	86	99	112	122	135	109
Head loss	(1)	kPa	30	33	25	34	26	29	32
Water flow rate	(2)	m³/h	115	129	146	166	179	201	162
Head loss	(2)	kPa	58	64	49	68	51	57	64
Condenser									
Quantity		n°	1	1	1	1	1	1	2
Water flow rate	(1)	m³/h	90	103	117	133	146	161	130
Head loss	(1)	kPa	43	41	42	39	43	50	42
Water flow rate	(2)	m³/h	87	98	110	125	136	152	123
Head loss	(2)	kPa	36	35	37	34	36	43	36
Compressors									
Compressors/Circuits		n°/n°	1/1	1/1	1/1	1/1	1/1	1/1	2/2
Minimum capacity reduction step	(3)	%	25%	25%	25%	25%	25%	25%	12,5%
Refrigerant charge	(7)	kg	85	83	80	75	76	78	104
Noise levels									
Sound power lev.	(4)	dB(A)	91	91	92	93	94	95	94
Sound pressure lev.	(5)	dB(A)	73	72	74	75	76	77	75
Sound power levels LN	(4)	dB(A)	86	86	87	88	89	90	89
Sound pressure levels LN	(5)	dB(A)	68	67	69	70	71	72	70
Sound power levels XLN	(4)	dB(A)	83	83	84	85	86	87	86
Sound pressure levels XLN	(5)	dB(A)	65	64	66	67	68	69	67
Dimensions and weights**									
Length		mm	4127	4671	4172	4175	4175	4455	4308
Depth		mm	900	900	900	900	900	900	1345
Height		mm	1950	1950	1988	1988	1996	1996	1842
Operating weight		kg	2879	2952	3255	3298	3379	3457	4058

- (1) Source-side heat exchanger inlet/outlet water temperature 30/35°C; user-side heat exchanger inlet/outlet water temperature 12/7°C. Values compliant with standard EN 14511
- (2) Source-side heat exchanger inlet/outlet water temperature 10/7°C; user-side heat exchanger inlet/outlet water temperature 40/45°C. Values compliant with standard EN 14511
- (3) Approximate value. The minimum capacity reached by the unit depends on the operating conditions. The value shown may not be suitable for calculating the minimum volume of water: to do this, consult the "Minimum water content in the system" section.
- (4) Unit operating at nominal operating capacity, without any accessories, with source/side heat exchanger inlet-outlet water temperature 30/35°C and user-side heat exchanger inlet/outlet water temperature 12/7°C. Values obtained from measures taken according to standard ISO 3744 and to the Eurovent certification programme where applicable. Binding values. See NOISE LEVELS section.
- (5) Values obtained from the sound power level (conditions in note 4), related to a distance of 1 m from the unit in free field with directivity factor Q=2. Non-binding values.
- (6) Unit operating at nominal operating capacity, with no options of any kind, with source-side heat exchanger input/output water temperature of 10/7°C and user-side heat exchanger water inlet-outlet temperature of 40/45°C. Values obtained from measurements carried out in accordance with standard ISO 3744.
- (7) Theoretical values referred to the basic unit (without DC). The amount of gas actually charged in the unit may differ.
- (10) Former Eurovent's seasonal efficiency index. Value not certified by Eurovent from 2019. Reference: base unit, without any accessories
- ** Basic unit without included accessories

OMEGA SKY HPW (R513A)

			72.2	88.2	101.2	116.2	132.2	143.2	159.2
Cooling									
Refrigeration capacity	(1)	kW	722	872	1006	1160	1319	1421	1500
Total absorbed power	(1)	kW	141	173	195	220	250	279	311
EER	(1)		5,12	5,05	5,16	5,27	5,28	5,1	4,83
Eurovent efficiency class	(1)		A	B	A	A	A	A	B
ESEER	(10)		6,18	6	6,13	6,34	6,25	6,16	6,34
Heating									
Heating capacity	(2)	kW	817	975	1122	1292	1471	1580	1791
Total absorbed power	(2)	kW	180	216	243	277	314	345	385
COP	(2)		4,55	4,52	4,61	4,67	4,69	4,58	4,66
Eurovent efficiency class	(2)		A	A	A	A	A	A	A
Evaporator									
Quantity		n°	1	1	1	1	1	1	1
Water flow rate	(1)	m³/h	124	150	173	200	227	245	270
Head loss	(1)	kPa	27	33	31	45	47	28	31
Water flow rate	(2)	m³/h	184	220	254	294	336	357	407
Head loss	(2)	kPa	54	64	60	89	93	55	60
Condenser									
Quantity		n°	2	2	2	2	2	2	2
Water flow rate	(1)	m³/h	148	179	206	236	269	291	321
Head loss	(1)	kPa	43	42	42	43	40	43	50
Water flow rate	(2)	m³/h	140	168	193	222	253	272	308
Head loss	(2)	kPa	37	36	35	37	35	36	43
Compressors									
Compressors/Circuits		n°/n°	2/2	2/2	2/2	2/2	2/2	2/2	2/2
Minimum capacity reduction step	(3)	%	12,5%	12,5%	12,5%	12,5%	12,5%	12,5%	12,5%
Refrigerant charge	(7)	kg	101	169	163	157	151	146	150
Noise levels									
Sound power lev.	(4)	dB(A)	94	94	94	95	96	97	98
Sound pressure lev.	(5)	dB(A)	75	75	75	76	77	78	79
Sound power levels LN	(4)	dB(A)	89	89	89	90	91	92	93
Sound pressure levels LN	(5)	dB(A)	70	70	70	71	72	73	74
Sound power levels XLN	(4)	dB(A)	86	86	86	87	88	89	90
Sound pressure levels XLN	(5)	dB(A)	67	67	67	68	69	70	71
Dimensions and weights**									
Length		mm	4308	5227	5188	4869	4860	5316	5166
Depth		mm	1345	1345	1350	1345	1345	1345	1350
Height		mm	1842	1928	2232	2004	2004	2004	2232
Operating weight		kg	4137	5330	5684	5816	6148	6962	7156

- (1) Source-side heat exchanger inlet/outlet water temperature 30/35°C; user-side heat exchanger inlet/outlet water temperature 12/7°C. Values compliant with standard EN 14511
- (2) Source-side heat exchanger inlet/outlet water temperature 10/7°C; user-side heat exchanger inlet/outlet water temperature 40/45°C. Values compliant with standard EN 14511
- (3) Approximate value. The minimum capacity reached by the unit depends on the operating conditions. The value shown may not be suitable for calculating the minimum volume of water: to do this, consult the "Minimum water content in the system" section.
- (4) Unit operating at nominal operating capacity, without any accessories, with source/side heat exchanger inlet-outlet water temperature 30/35°C and user-side heat exchanger inlet/outlet water temperature 12/7°C. Values obtained from measures taken according to standard ISO 3744 and to the Eurovent certification programme where applicable. Binding values. See NOISE LEVELS section.
- (5) Values obtained from the sound power level (conditions in note 4), related to a distance of 1 m from the unit in free field with directivity factor Q=2. Non-binding values.
- (6) Unit operating at nominal operating capacity, with no options of any kind, with source-side heat exchanger input/output water temperature of 10/7°C and user-side heat exchanger water inlet-outlet temperature of 40/45°C. Values obtained from measurements carried out in accordance with standard ISO 3744.
- (7) Theoretical values referred to the basic unit (without DC). The amount of gas actually charged in the unit may differ.
- (10) Former Eurovent's seasonal efficiency index. Value not certified by Eurovent from 2019. Reference: base unit, without any accessories
- ** Basic unit without included accessories

OMEGA SKY HPW (R134a)

			43.1	50.1	58.1	66.1	70.1	79.1	63.2
Cooling									
Refrigeration capacity	(1)	kW	431	496	567	642	699	774	626
Total absorbed power	(1)	kW	83	94	105	119	134	150	119
EER	(1)		5,18	5,26	5,38	5,37	5,2	5,16	5,24
ISEER	(8)		-	-	-	-	-	-	-
IPLV	(9)		7,021	7,046	7,249	7,257	7,23	6,882	7,104
ESEER	(10)		6,13	6,13	6,35	6,28	6,2	6,21	6,35
Eurovent efficiency class	(1)		A	A	A	A	A	A	A
Heating									
Heating capacity	(2)	kW	488	555	636	720	783	868	709
Total absorbed power	(2)	kW	103	118	132	151	167	186	152
COP	(2)		4,73	4,69	4,82	4,77	4,69	4,66	4,66
Eurovent efficiency class	(2)		A	A	A	A	A	A	A
Evaporator									
Quantity		n°	1	1	1	1	1	1	1
Water flow rate	(1)	m³/h	74	85	98	111	120	133	108
Head loss	(1)	kPa	29	31	24	32	25	27	31
Water flow rate	(2)	m³/h	111	126	146	164	178	197	161
Head loss	(2)	kPa	57	62	48	66	50	55	62
Condenser									
Quantity		n°	1	1	1	1	1	1	2
Water flow rate	(1)	m³/h	88	101	115	130	143	158	128
Head loss	(1)	kPa	40	39	40	37	40	48	39
Water flow rate	(2)	m³/h	84	95	109	124	135	149	122
Head loss	(2)	kPa	35	34	35	33	35	42	35
Compressors									
Compressors/Circuits		n°/n°	1/1	1/1	1/1	1/1	1/1	1/1	2/2
Minimum capacity reduction step	(3)	%	25%	25%	25%	25%	25%	25%	12,5%
Refrigerant charge	(7)	kg	74	73	71	68	69	71	91
Noise levels									
Sound power lev.	(4)	dB(A)	91	91	92	93	94	95	94
Sound pressure lev.	(5)	dB(A)	73	72	74	75	76	77	75
Sound power levels LN	(4)	dB(A)	86	86	87	88	89	90	89
Sound pressure levels LN	(5)	dB(A)	68	67	69	70	71	72	70
Sound power levels XLN	(4)	dB(A)	83	83	84	85	86	87	86
Sound pressure levels XLN	(5)	dB(A)	65	64	66	67	68	69	67
Dimensions and weights**									
Length		mm	4127	4671	4172	4175	4175	4455	4308
Depth		mm	900	900	900	900	900	900	1345
Height		mm	1950	1950	1988	1988	1996	1996	1842
Operating weight		kg	2879	2952	3255	3298	3379	3457	4058

- (1) Source-side heat exchanger inlet/outlet water temperature 30/35°C; user-side heat exchanger inlet/outlet water temperature 12/7°C. Values compliant with standard EN 14511
 - (2) Source-side heat exchanger inlet/outlet water temperature 10/7°C; user-side heat exchanger inlet/outlet water temperature 40/45°C. Values compliant with standard EN 14511
 - (3) Approximate value. The minimum capacity reached by the unit depends on the operating conditions. The value shown may not be suitable for calculating the minimum volume of water: to do this, consult the "Minimum water content in the system" section.
 - (4) Unit operating at nominal operating capacity, without any accessories, with source-side heat exchanger inlet-outlet water temperature 30/35°C and user-side heat exchanger inlet/outlet water temperature 12/7°C. Values obtained from measures taken according to standard ISO 3744 and to the Eurovent certification programme where applicable. Binding values. See NOISE LEVELS section.
 - (5) Values obtained from the sound power level (conditions in note 4), related to a distance of 1 m from the unit in free field with directivity factor Q=2. Non-binding values.
 - (6) Unit operating at nominal operating capacity, with no options of any kind, with source-side heat exchanger input/output water temperature of 10/7°C and user-side heat exchanger water inlet-outlet temperature of 40/45°C. Values obtained from measurements carried out in accordance with standard ISO 3744.
 - (7) Theoretical values referred to the basic unit (without DC). The amount of gas actually charged in the unit may differ.
 - (8) Reference to IS16590:2017, user-side heat exchanger outlet temperature 7 °C. Source-side heat exchanger inlet temperatures : part load 100% - W39°C; part load 75% - W32°C; part load 50% - W26°C; part load 25% - W20°C.
 - (9) Reference to AHRI 550/590, user-side heat exchanger outlet temperature 6,7 °C. Source-side heat exchanger inlet temperatures : part load 100% - W 35°C; part load 75% - W 26,7°C; part load 50% - W 18,3°C; part load 25% - W 12,8°C.
 - (10) Former Eurovent's seasonal efficiency index. Value not certified by Eurovent from 2019. Reference: base unit, without any accessories
- ** Basic unit without included accessories

OMEGA SKY HPW (R134a)

			72.2	88.2	101.2	116.2	132.2	143.2	159.2
Cooling									
Refrigeration capacity	(1)	kW	712	860	993	1144	1303	1400	1500
Total absorbed power	(1)	kW	136	166	187	212	240	268	299
EER	(1)		5,24	5,18	5,29	5,39	5,42	5,21	5,17
ISEER	(8)		-	-	-	-	-	-	-
IPLV	(9)		7,078	6,872	6,977	7,226	7,281	7,087	7,194
ESEER	(10)		6,37	6,15	6,29	6,37	6,43	6,35	6,35
Eurovent efficiency class	(1)		A	A	A	A	A	A	A
Heating									
Heating capacity	(2)	kW	807	968	1112	1282	1458	1566	1742
Total absorbed power	(2)	kW	173	208	236	266	302	334	369
COP	(2)		4,66	4,64	4,72	4,81	4,83	4,69	4,72
Eurovent efficiency class	(2)		A	A	A	A	A	A	A
Evaporator									
Quantity		n°	1	1	1	1	1	1	1
Water flow rate	(1)	m³/h	123	148	171	197	224	241	266
Head loss	(1)	kPa	26	31	29	43	45	27	29
Water flow rate	(2)	m³/h	183	219	253	294	334	355	396
Head loss	(2)	kPa	52	63	58	87	91	54	58
Condenser									
Quantity		n°	2	2	2	2	2	2	2
Water flow rate	(1)	m³/h	145	176	202	232	264	286	316
Head loss	(1)	kPa	40	40	39	41	38	40	48
Water flow rate	(2)	m³/h	139	166	191	220	251	269	299
Head loss	(2)	kPa	36	35	34	36	33	35	42
Compressors									
Compressors/Circuits		n°/n°	2/2	2/2	2/2	2/2	2/2	2/2	2/2
Minimum capacity reduction step	(3)	%	12,5%	12,5%	12,5%	12,5%	12,5%	12,5%	12,5%
Refrigerant charge	(7)	kg	90	148	144	139	136	132	136
Noise levels									
Sound power lev.	(4)	dB(A)	94	94	94	95	96	97	98
Sound pressure lev.	(5)	dB(A)	75	75	75	76	77	78	79
Sound power levels LN	(4)	dB(A)	89	89	89	90	91	92	93
Sound pressure levels LN	(5)	dB(A)	70	70	70	71	72	73	74
Sound power levels XLN	(4)	dB(A)	86	86	86	87	88	89	90
Sound pressure levels XLN	(5)	dB(A)	67	67	67	68	69	70	71
Dimensions and weights**									
Length		mm	4308	5227	5188	4869	4860	5316	5166
Depth		mm	1345	1345	1350	1345	1345	1345	1350
Height		mm	1842	1928	2232	2004	2004	2004	2232
Operating weight		kg	4137	5330	5684	5816	6148	6962	7156

- (1) Source-side heat exchanger inlet/outlet water temperature 30/35°C; user-side heat exchanger inlet/outlet water temperature 12/7°C. Values compliant with standard EN 14511
 - (2) Source-side heat exchanger inlet/outlet water temperature 10/7°C; user-side heat exchanger inlet/outlet water temperature 40/45°C. Values compliant with standard EN 14511
 - (3) Approximate value. The minimum capacity reached by the unit depends on the operating conditions. The value shown may not be suitable for calculating the minimum volume of water: to do this, consult the "Minimum water content in the system" section.
 - (4) Unit operating at nominal operating capacity, without any accessories, with source-side heat exchanger inlet-outlet water temperature 30/35°C and user-side heat exchanger inlet/outlet water temperature 12/7°C. Values obtained from measures taken according to standard ISO 3744 and to the Eurovent certification programme where applicable. Binding values. See NOISE LEVELS section.
 - (5) Values obtained from the sound power level (conditions in note 4), related to a distance of 1 m from the unit in free field with directivity factor Q=2. Non-binding values.
 - (6) Unit operating at nominal operating capacity, with no options of any kind, with source-side heat exchanger input/output water temperature of 10/7°C and user-side heat exchanger water inlet-outlet temperature of 40/45°C. Values obtained from measurements carried out in accordance with standard ISO 3744.
 - (7) Theoretical values referred to the basic unit (without DC). The amount of gas actually charged in the unit may differ.
 - (8) Reference to IS16590:2017, user-side heat exchanger outlet temperature 7 °C. Source-side heat exchanger inlet temperatures : part load 100% - W39°C; part load 75% - W32°C; part load 50% - W26°C; part load 25% - W20°C.
 - (9) Reference to AHRI 550/590, user-side heat exchanger outlet temperature 6,7 °C. Source-side heat exchanger inlet temperatures : part load 100% - W 35°C; part load 75% - W 26,7°C; part load 50% - W 18,3°C; part load 25% - W 12,8°C.
 - (10) Former Eurovent's seasonal efficiency index. Value not certified by Eurovent from 2019. Reference: base unit, without any accessories
- ** Basic unit without included accessories

OMEGA SKY LC

			43.1	50.1	58.1	66.1	70.1	79.1	63.2
R513A									
Cooling									
Refrigeration capacity	(1)	kW	380	441	513	582	632	689	566
Total absorbed power	(1)	kW	108	121	141	160	177	191	164
EER	(1)		3,51	3,65	3,64	3,65	3,58	3,6	3,45
Eurovent efficiency class	(1)		B	A	A	A	A	A	B
User-side heat exchanger									
Quantity		n°	1	1	1	1	1	1	1
Water flow rate	(2)	m ³ /h	65	76	88	100	109	119	97
Head loss	(2)	kPa	21	24	19	26	20	21	24
R134a									
Cooling									
Refrigeration capacity	(1)	kW	378	443	508	577	626	684	562
Total absorbed power	(1)	kW	104	117	136	154	175	188	158
EER	(1)		3,62	3,78	3,73	3,74	3,57	3,63	3,55
Eurovent efficiency class	(1)		A	A	A	A	A	A	B
User-side heat exchanger									
Quantity		n°	1	1	1	1	1	1	1
Water flow rate	(2)	m ³ /h	65	76	87	99	108	118	97
Head loss	(2)	kPa	21	24	18	25	19	21	24
Compressors									
Compressors/Circuits		n°/n°	1/1	1/1	1/1	1/1	1/1	1/1	2/2
Minimum capacity reduction step	(7)	%	25%	25%	25%	25%	25%	25%	12,5%
Noise levels									
Sound power lev.	(4)	dB(A)	91	91	92	93	94	95	94
Sound pressure lev.	(5)	dB(A)	73	72	74	75	76	77	75
Sound power lev. LN vers.	(4)	dB(A)	86	86	87	88	89	90	89
Sound pressure lev. LN vers.	(5)	dB(A)	68	67	69	70	71	72	70
Sound power level XLN vers.	(4)	dB(A)	83	83	84	85	86	87	86
Sound pressure level XLN vers.	(5)	dB(A)	65	64	66	67	68	69	67
Dimensions and weights**									
Length		mm	4.090	4.680	4.120	4.180	4.180	4.460	4.600
Depth		mm	900	900	900	900	900	900	1.300
Height		mm	1.600	1.600	1.600	1.600	1.600	1.600	1.500
Operating weight		kg	2.245	2.314	2.619	2.665	2.742	2.818	3.161
Diameters and refig. circuit connections									
Suction line diameter		mm	76	76	76	89	89	89	67
Liquid line diameter		mm	54	54	54	67	67	67	42

Partly completed machinery: conformity with Ecodesign depends on the combination with the remote heat exchanger. CE marked units.

Preliminary data for units in R513A.

Dimensions and weights not contractually binding, to be considered preliminary. Available on request.

(1) Condensing temperature 50°C; user-side heat exchanger inlet/outlet water temperature 12/7°C.

(4) Unit operating at nominal operating capacity, without any accessories, condensing temperature 50°C and user-side heat exchanger inlet-outlet water temperature 12-7°C. Binding values. Values obtained from measures taken according to standard ISO 3744 and to the Eurovent certification programme where applicable.

(5) Values obtained from the sound power level (conditions: note 4), related to a distance of 1 m from the unit in free field with directivity factor Q=2. Non-binding values.

(6) Theoretical values referred to the basic unit (without DC). The amount of gas actually charged in the unit may differ.

(7) Approximate value. The minimum capacity reached by the unit depends on the operating conditions. The value shown may not be suitable for calculating the minimum volume of water: to do this, consult the "Minimum water content in the system" section.

** Basic CH unit without included accessories

OMEGA SKY LC

			72.2	88.2	101.2	116.2	132.2	143.2	159.2
R513A									
Cooling									
Refrigeration capacity	(1)	kW	643	759	884	1037	1182	1265	1377
Total absorbed power	(1)	kW	187	216	241	283	320	353	382
EER	(1)		3,44	3,51	3,66	3,66	3,69	3,58	3,6
Eurovent efficiency class	(1)		B	B	A	A	A	A	A
User-side heat exchanger									
Quantity		n°	1	1	1	1	1	1	1
Water flow rate	(2)	m ³ /h	111	131	152	178	203	218	237
Head loss	(2)	kPa	20	24	22	34	36	21	23
R134a									
Cooling									
Refrigeration capacity	(1)	kW	640	754	889	1027	1171	1253	1367
Total absorbed power	(1)	kW	180	209	234	273	309	350	376
EER	(1)		3,56	3,61	3,8	3,76	3,79	3,58	3,63
Eurovent efficiency class	(1)		A	A	A	A	A	A	A
User-side heat exchanger									
Quantity		n°	1	1	1	1	1	1	1
Water flow rate	(2)	m ³ /h	110	130	153	177	202	216	235
Head loss	(2)	kPa	20	23	22	33	35	21	22
Compressors									
Compressors/Circuits		n°/n°	2/2	2/2	2/2	2/2	2/2	2/2	2/2
Minimum capacity reduction step	(7)	%	12,5%	12,5%	12,5%	12,5%	12,5%	12,5%	12,5%
Noise levels									
Sound power lev.	(4)	dB(A)	94	94	94	95	96	97	98
Sound pressure lev.	(5)	dB(A)	75	75	75	76	77	78	79
Sound power lev. LN vers.	(4)	dB(A)	89	89	89	90	91	92	93
Sound pressure lev. LN vers.	(5)	dB(A)	70	70	70	71	72	73	74
Sound power level XLN vers.	(4)	dB(A)	86	86	86	87	88	89	90
Sound pressure level XLN vers.	(5)	dB(A)	67	67	67	68	69	70	71
Dimensions and weights**									
Length		mm	4.600	5.280	4.980	4.980	5.250	5.380	5.380
Depth		mm	1.300	1.300	1.300	1.300	1.300	1.350	1.350
Height		mm	1.500	1.530	1.610	1.610	1.610	1.840	1.840
Operating weight		kg	3.184	4.166	4.490	4.619	4.926	5.737	5.929
Diameters and refig. circuit connections									
Suction line diameter		mm	67	76	76	76	89	89	89
Liquid line diameter		mm	42	54	54	54	67	67	67

Partly completed machinery: conformity with Ecodesign depends on the combination with the remote heat exchanger. CE marked units.

Preliminary data for units in R513A.

Dimensions and weights not contractually binding, to be considered preliminary. Available on request.

(1) Condensing temperature 50°C; user-side heat exchanger inlet/outlet water temperature 12/7°C.

(4) Unit operating at nominal operating capacity, without any accessories, condensing temperature 50°C and user-side heat exchanger inlet-outlet water temperature 12-7°C. Binding values. Values obtained from measures taken according to standard ISO 3744 and to the Eurovent certification programme where applicable.

(5) Values obtained from the sound power level (conditions: note 4), related to a distance of 1 m from the unit in free field with directivity factor Q=2. Non-binding values.

(6) Theoretical values referred to the basic unit (without DC). The amount of gas actually charged in the unit may differ.

(7) Approximate value. The minimum capacity reached by the unit depends on the operating conditions. The value shown may not be suitable for calculating the minimum volume of water: to do this, consult the "Minimum water content in the system" section.

** Basic CH unit without included accessories

ECODESIGN

INTRODUCTION

The Ecodesign/ErP Directive (2009/125/EC) lays down new standards for more efficient energy use.

The Directive contains various regulations; as regards chiller products and heat pumps, the regulations of interest are the following:

- Regulation 2013/813, for small heat pumps ($P_{\text{design}} \leq 400$ kW)
- Regulation 2016/2281, for chillers and heat pumps with $P_{\text{design}} > 400$ kW
- Regulation 2013/811, for heat pumps with $P_{\text{design}} \leq 70$ kW.

The last-mentioned regulation (2013/811) regards the labelling (Ecolabel certification) of small heat pumps.

The other two regulations (2013/813 and 2016/2281) set seasonal efficiency targets that the products must comply with to be sold and installed in the European Union (essential requirement for CE marking).

These efficiency limits are defined through ratios, which are respectively:

- η_{sh} (SCOP), with reference to regulation 2013/813
- η_{sc} (SEER) for comfort applications and SEPR for process applications, with reference to regulation 2016/2281.

As regards regulation 2016/2281, with effect from 1st January 2021, the required minimum efficiency limit will be raised (Tier 2) from the current threshold (Tier 1).

The figure below schematically illustrates the correspondence between product and reference energy ratio.

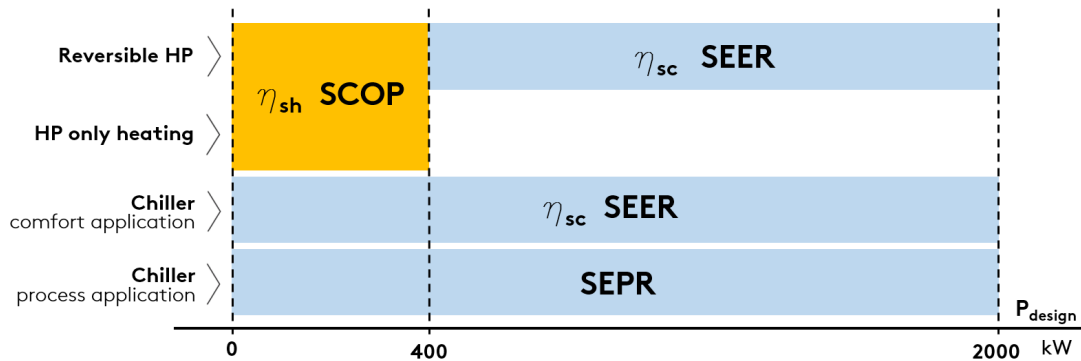

Some notes and clarifications:

For comfort applications, regulation 2016/2281 sets the η_{sc} (SEER) ratio in two different operating conditions:

- SEER calculated with machine inlet/outlet water temperature of 12/7°C (low temperature application),
- SEER calculated with machine inlet/outlet water temperature of 23/18°C (medium temperature application).

The minimum efficiency requirement is the same, but can be met at condition 12/7°C or at condition 23/18°C, depending on the application envisaged for the machine.

Regulation 2013/813 distinguishes two different types: at low temperature and at medium temperature.

The following refer to the application at low temperature: (low temperature application) all heat pumps whose maximum delivery temperature for heating purposes is lower than 52°C with source at temperature of -7°C and -8°C wet bulb (air-water unit) or inlet 10°C (water-water unit), at the reference design conditions for an average climate. For these, the efficiency ratio is "low temperature application" (outlet water temperature 35°C).

For all the other heat pumps, the efficiency ratio is related to "medium temperature application" (outlet water temperature 55°C).

The ratios must be calculated according to the reference European heating season in average climatic conditions.

The minimum efficiency requirements set by the regulations are indicated below.

REGULATION 2016/2281, comfort application

TYPE OF UNIT		MINIMUM REQUIREMENT			
		Tier 1		Tier 2 (2021)	
SOURCE	P _{design}	η_{sc} [%]	SEER	η_{sc} [%]	SEER
air	< 400kW	149	3,8	161	4,1
air	\geq 400kW	161	4,1	179	4,55
water	< 400kW	196	4,975	200	5,075
water	\geq 400kW and < 1500kW	227	5,75	252	6,375
water	\geq 1500kW	245	6,2	272	6,875

REGULATION 2016/2281, process application

TYPE OF UNIT		MINIMUM REQUIREMENT	
		Tier 1	Tier 2 (2021)
SOURCE	P _{design}	SEPR	SEPR
air	< 400kW	4,5	5
air	\geq 400kW	5	5,5
water	< 400kW	6,5	7
water	\geq 400kW and < 1500kW	7,5	8
water	\geq 1500kW	8	8,5

REGULATION 2013/813

SOURCE	APPLICATION	MINIMUM REQUIREMENT	
		η_{sh} [%]	SCOP
air	low temperature application	125	3,2
water	low temperature application	125	3,325
air	medium temperature application	110	2,825
water	medium temperature application	110	2,95

The conformity of the product must be checked according to the type of application, whether comfort or process, and at the required outlet water temperature.

The two schematic tables below, respectively for comfort application and for process application, indicate the reference of the required conformity according to the type of product and the set point temperature (reference to regulations 2016/2281 and 2013/813).

Important note: for mixed comfort and process applications, the reference application for conformity is the comfort application.

COMFORT APPLICATION

PRODUCT	OUTLET WATER TEMPERATURE	COMPLIANCE INDEX	REGULATION
Chiller	< 18°C	SEER/η _{sc} low temperature application	2016/2281
	≥ 18°C	SEER/η _{sc} medium temperature application	2016/2281
Heat pumps (reversible and only heating) P_{design} ≤ 400kW		SCOP/η _{sh}	2013/813
Reversible heat pumps P_{design} > 400kW	< 18°C	SEER/η _{sc} low temperature application	2016/2281
	≥ 18°C	SEER/η _{sc} medium temperature application	2016/2281
Heat pumps only heating P_{design} > 400kW		-	-

- = exemption from Ecodesign

PROCESS APPLICATION

PRODUCT	OUTLET WATER TEMPERATURE	COMPLIANCE INDEX	REGULATION
Chiller	≥ +2°C , ≤ 12°C	SEPR	2016/2281
	> 12°C	-	-
	> -8°C , < +2°C	-	-

- = exemption from Ecodesign

Some specifications and notes follow.

Partly completed machinery

The term partly completed machinery refers to all units without a user-side or source-side heat exchanger, and therefore to all LC, LE, LC/HP and LE/HP versions. Since these are "non-complete" machines, conformity with Ecodesign depends on combination with the remote heat exchanger.

All the partly completed machinery is CE marked and accompanied by a declaration of conformity. Installation in European Union countries is therefore allowed; correct selection and installation of the remote heat exchanger must be ensured, in accordance with the above cases.

EC fans:

The only option that positively affects the performance of the unit, by increasing its seasonal energy efficiency ratio, is the VEC accessory.

A unit equipped with EC fans has a higher SEER (η_{sc}) than the configuration with standard fans.

OMEGA SKY RANGE

As specifically regards the Omega Sky range, the regulations of interest for the various units in various configurations are indicated below.

Omega Sky:

- regulation 2016/2281

Omega Sky OH:

Since they are heat pumps for only heating with Pdesign>400kW, the units are exempt from any compliance. All OH units are CE marked.

Omega Sky HPW:

- regulation 2016/2281

Omega Sky LC:

Since these are partly completed machines, conformity with Ecodesign depends on combination with the remote heat exchanger.

All LC units are CE marked.

The tables below give information on the conformity of the units and the seasonal energy performance ratios with regard to the reference regulation.

OMEGA SKY

			43.1	50.1	58.1	66.1	70.1	79.1	63.2
R513A									
REGULATION 2016/2281									
Pdesign	(1)	kW	437	502	574	651	710	783	635
COMFORT									
ηsc	(1)	%	253%	254%	256%	254%	259%	254%	257%
SEER	(1)		6,4	6,42	6,47	6,43	6,54	6,41	6,5
Compliance Tier 1	(1)		Y	Y	Y	Y	Y	Y	Y
Compliance Tier 2 (2021)	(1)		Y	Y	Y	Y	Y	Y	Y
PROCESS									
SEPR	(3)		RFQ	RFQ	RFQ	RFQ	RFQ	RFQ	RFQ
Compliance Tier 1	(3)		Y	Y	Y	Y	Y	Y	Y
Compliance Tier 2 (2021)	(3)		RFQ	RFQ	RFQ	RFQ	RFQ	RFQ	RFQ
R134a									
REGULATION 2016/2281									
Pdesign	(1)	kW	431	496	567	642	699	774	626
COMFORT									
ηsc	(1)	%	254%	256%	258%	261%	261%	258%	260%
SEER	(1)		6,42	6,46	6,52	6,59	6,61	6,52	6,58
Compliance Tier 1	(1)		Y	Y	Y	Y	Y	Y	Y
Compliance Tier 2 (2021)	(1)		Y	Y	Y	Y	Y	Y	Y
PROCESS									
SEPR	(3)		RFQ	RFQ	RFQ	RFQ	RFQ	RFQ	RFQ
Compliance Tier 1	(3)		Y	Y	Y	Y	Y	Y	Y
Compliance Tier 2 (2021)	(3)		RFQ	RFQ	RFQ	RFQ	RFQ	RFQ	RFQ

Y = unit in compliance with Ecodesign at the indicated condition.

N = unit not in compliance with Ecodesign at the given condition: it can be installed only in non-EU countries.

- = value not necessary: conformity is already provided at the most restrictive condition (1).

(1) User-side heat exchanger water inlet/outlet temperature 12/7°C (low temperature application), with reference to regulation 2016/2281 and standard EN 14825.

(3) User-side heat exchanger water inlet/outlet temperature 12/7°C, with reference to regulation 2016/2281 and norm EN 14825.

OMEGA SKY

			72.2	88.2	101.2	116.2	132.2	143.2	159.2
R513A									
REGULATION 2016/2281									
Pdesign	(1)	kW	722	872	1006	1160	1319	1421	1500
COMFORT									
η_{sc}	(1)	%	255%	254%	257%	257%	256%	254%	257%
SEER	(1)		6,44	6,43	6,51	6,5	6,47	6,43	6,49
Compliance Tier 1	(1)		Y	Y	Y	Y	Y	Y	Y
Compliance Tier 2 (2021)	(1)		Y	Y	Y	Y	Y	Y	Y
PROCESS									
SEPR	(3)		RFQ	RFQ	RFQ	RFQ	RFQ	RFQ	8,02
Compliance Tier 1	(3)		Y	Y	Y	Y	Y	Y	Y
Compliance Tier 2 (2021)	(3)		RFQ	RFQ	RFQ	RFQ	RFQ	RFQ	Y
R134a									
REGULATION 2016/2281									
Pdesign	(1)	kW	712	860	993	1144	1303	1400	1500
COMFORT									
η_{sc}	(1)	%	258%	258%	262%	259%	261%	261%	259%
SEER	(1)		6,53	6,52	6,62	6,54	6,61	6,59	6,54
Compliance Tier 1	(1)		Y	Y	Y	Y	Y	Y	Y
Compliance Tier 2 (2021)	(1)		Y	Y	Y	Y	Y	Y	Y
PROCESS									
SEPR	(3)		RFQ	RFQ	RFQ	RFQ	RFQ	RFQ	8,07
Compliance Tier 1	(3)		Y	Y	Y	Y	Y	Y	Y
Compliance Tier 2 (2021)	(3)		RFQ	RFQ	RFQ	RFQ	RFQ	RFQ	Y

Y = unit in compliance with Ecodesign at the indicated condition.

N = unit not in compliance with Ecodesign at the given condition: it can be installed only in non-EU countries.

- = value not necessary: conformity is already provided at the most restrictive condition (1).

(1) User-side heat exchanger water inlet/outlet temperature 12/7°C (low temperature application), with reference to regulation 2016/2281 and standard EN 14825.

(3) User-side heat exchanger water inlet/outlet temperature 12/7°C, with reference to regulation 2016/2281 and norm EN 14825.

OMEGA SKY HPW

			43.1	50.1	58.1	66.1	70.1	79.1	63.2
R513A									
REGULATION 2016/2281									
Pdesign	(1)	kW	437	502	574	651	710	783	635
COMFORT									
η_{sc}	(1)	%	253%	254%	256%	254%	259%	254%	257%
SEER	(1)		6,4	6,42	6,47	6,43	6,54	6,41	6,5
Compliance Tier 1	(1)		Y	Y	Y	Y	Y	Y	Y
Compliance Tier 2 (2021)	(1)		Y	Y	Y	Y	Y	Y	Y
R134a									
REGULATION 2016/2281									
Pdesign	(1)	kW	431	496	567	642	699	774	626
COMFORT									
η_{sc}	(1)	%	254%	256%	258%	261%	261%	258%	260%
SEER	(1)		6,42	6,46	6,52	6,59	6,61	6,52	6,58
Compliance Tier 1	(1)		Y	Y	Y	Y	Y	Y	Y
Compliance Tier 2 (2021)	(1)		Y	Y	Y	Y	Y	Y	Y

Y = unit in compliance with Ecodesign at the indicated condition.

N = unit not in compliance with Ecodesign at the given condition: it can be installed only in non-EU countries.

- = value not necessary: conformity is already provided at the most restrictive condition (1).

(1) User-side heat exchanger water inlet/outlet temperature 12/7°C (low temperature application), with reference to regulation 2016/2281 and standard EN 14825.

			72.2	88.2	101.2	116.2	132.2	143.2	159.2
R513A									
REGULATION 2016/2281									
Pdesign	(1)	kW	722	872	1006	1160	1319	1421	1500
COMFORT									
η_{sc}	(1)	%	255%	254%	257%	257%	256%	254%	257%
SEER	(1)		6,44	6,43	6,51	6,5	6,47	6,43	6,49
Compliance Tier 1	(1)		Y	Y	Y	Y	Y	Y	Y
Compliance Tier 2 (2021)	(1)		Y	Y	Y	Y	Y	Y	Y
R134a									
REGULATION 2016/2281									
Pdesign	(1)	kW	712	860	993	1144	1303	1400	1500
COMFORT									
η_{sc}	(1)	%	258%	258%	262%	259%	261%	261%	259%
SEER	(1)		6,53	6,52	6,62	6,54	6,61	6,59	6,54
Compliance Tier 1	(1)		Y	Y	N	Y	Y	N	Y
Compliance Tier 2 (2021)	(1)		Y	Y	Y	Y	Y	Y	Y

Y = unit in compliance with Ecodesign at the indicated condition.

N = unit not in compliance with Ecodesign at the given condition: it can be installed only in non-EU countries.

- = value not necessary: conformity is already provided at the most restrictive condition (1).

(1) User-side heat exchanger water inlet/outlet temperature 12/7°C (low temperature application), with reference to regulation 2016/2281 and standard EN 14825.

ELECTRICAL SPECIFICATIONS

OMEGA SKY

			43.1	50.1	58.1	66.1	70.1	79.1	63.2
General electrical specifications									
Max. absorbed power (FLI)	(1)	kW	125	142	159	180	200	221	183
Max. absorbed current (FLA)	(1)	A	210	235	262	299	338	369	312
Rated current (Inom)	(2)	A	150	168	187	217	246	270	226
cosφ standard unit	(2)		0,87	0,87	0,89	0,86	0,86	0,86	0,84
Nominal current with power factor correction (Inom)	(2)	A	136	152	173	193	223	241	196
cosφ unit with power factor correction	(2)		0,96	0,96	0,96	0,96	0,96	0,96	0,97
Max. inrush current (MIC)	(3)	A	318	436	465	586	650	805	423
Power supply		V/ph/Hz	400V / 3ph / 50Hz						
Power supply for auxiliary circuits		V/ph/Hz	230V-24V / 1ph / 50Hz						
Suggested line section	(4)	mm ²	3x120+1G72	3x150+1G97		3x240+1G120		2x(3x120+1G70)	3x240+1G120
Suggested line protection	(5)		NH1gG 250A	NH2gG 315A		NH2gG 400A		NH3gG 500A	NH2gG 400A

- (1) Data regarding the unit without accessories working in maximum power absorption conditions
- (2) Data referred to the unit without accessories operating at standard conditions: water inlet/outlet temperature from the source heat exchanger 30/35°C, water inlet/outlet temperature from the user heat exchanger 12/7°C.
- (3) Maximum effective RMS value of the current when the last compressor starts (FLA of the entire unit - FLA of the largest compressor + LRA of the largest compressor)
- (4) These values are determined for cables with operating temperature of 40°C, EPR insulation and a line with a maximum length of 50m. The line section must be determined by a qualified technician based on the protection devices, the length of the line, the type of cable used and the type of installation.
- (5) The correct line protection part must be determined by a qualified technician based on the length of the line, the type of cable used and the type of installation.

			72.2	88.2	101.2	116.2	132.2	143.2	159.2
General electrical specifications									
Max. absorbed power (FLI)	(1)	kW	209	250	283	318	360	400	442
Max. absorbed current (FLA)	(1)	A	354	420	470	524	598	676	738
Rated current (Inom)	(2)	A	257	300	337	374	434	492	540
cosφ standard unit	(2)		0,83	0,87	0,87	0,89	0,86	0,86	0,86
Nominal current with power factor correction (Inom)	(2)	A	220	272	303	343	387	445	492
cosφ unit with power factor correction	(2)		0,97	0,96	0,97	0,97	0,96	0,96	0,95
Max. inrush current (MIC)	(3)	A	491	538	671	727	885	988	1174
Power supply		V/ph/Hz	400V / 3ph / 50Hz						
Power supply for auxiliary circuits		V/ph/Hz	230V-24V / 1ph / 50Hz						
Suggested line section	(4)	mm ²	3x240+1G120	2x(3x120+1G70)	2x(3x150+1G95)		2x(3x185+1G95)		2x(3x240+1G120)
Suggested line protection	(5)		NH2gG 400A	NH3gG 500A	NH3gG 630A		NH4gG 700A		NH4gG 800A

- (1) Data regarding the unit without accessories working in maximum power absorption conditions
- (2) Data referred to the unit without accessories operating at standard conditions: water inlet/outlet temperature from the source heat exchanger 30/35°C, water inlet/outlet temperature from the user heat exchanger 12/7°C.
- (3) Maximum effective RMS value of the current when the last compressor starts (FLA of the entire unit - FLA of the largest compressor + LRA of the largest compressor)
- (4) These values are determined for cables with operating temperature of 40°C, EPR insulation and a line with a maximum length of 50m. The line section must be determined by a qualified technician based on the protection devices, the length of the line, the type of cable used and the type of installation.
- (5) The correct line protection part must be determined by a qualified technician based on the length of the line, the type of cable used and the type of installation.

OMEGA SKY HPW

			43.1	50.1	58.1	66.1	70.1	79.1	63.2
General electrical specifications									
Max. absorbed power (FLI)	(1)	kW	125	142	159	180	200	221	183
Max. absorbed current (FLA)	(1)	A	210	235	262	299	338	369	312
Rated current (Inom)	(2)	A	150	168	187	217	246	270	226
cosφ standard unit	(2)		0,87	0,87	0,89	0,86	0,86	0,86	0,84
Nominal current with power factor correction (Inom)	(2)	A	136	152	173	193	223	241	196
cosφ unit with power factor correction	(2)		0,96	0,96	0,96	0,96	0,96	0,96	0,97
Max. inrush current (MIC)	(3)	A	318	436	465	586	650	805	423
Power supply		V/ph/Hz	400V / 3ph / 50Hz						
Power supply for auxiliary circuits		V/ph/Hz	230V-24V / 1ph / 50Hz						
Suggested line section	(4)	mm ²	3x120+1G72	3x150+1G97		3x240+1G120		2x(3x120+1G70)	3x240+1G120
Suggested line protection	(5)		NH1gG 250A	NH2gG 315A		NH2gG 400A		NH3gG 500A	NH2gG 400A

- (1) Data regarding the unit without accessories working in maximum power absorption conditions
- (2) Data referred to the unit without accessories operating at standard conditions: water inlet/outlet temperature from the source heat exchanger 30/35°C, water inlet/outlet temperature from the user heat exchanger 12/7°C.
- (3) Maximum effective RMS value of the current when the last compressor starts (FLA of the entire unit - FLA of the largest compressor + LRA of the largest compressor)
- (4) These values are determined for cables with operating temperature of 40°C, EPR insulation and a line with a maximum length of 50m. The line section must be determined by a qualified technician based on the protection devices, the length of the line, the type of cable used and the type of installation.
- (5) The correct line protection part must be determined by a qualified technician based on the length of the line, the type of cable used and the type of installation.

			72.2	88.2	101.2	116.2	132.2	143.2	159.2
General electrical specifications									
Max. absorbed power (FLI)	(1)	kW	209	250	283	318	360	400	442
Max. absorbed current (FLA)	(1)	A	354	420	470	524	598	676	738
Rated current (Inom)	(2)	A	257	300	337	374	434	492	540
cosφ standard unit	(2)		0,83	0,87	0,87	0,89	0,86	0,86	0,86
Nominal current with power factor correction (Inom)	(2)	A	220	272	303	343	387	445	492
cosφ unit with power factor correction	(2)		0,97	0,96	0,97	0,97	0,96	0,96	0,95
Max. inrush current (MIC)	(3)	A	491	538	671	727	885	988	1174
Power supply		V/ph/Hz	400V / 3ph / 50Hz						
Power supply for auxiliary circuits		V/ph/Hz	230V-24V / 1ph / 50Hz						
Suggested line section	(4)	mm ²	3x240+1G120	2x(3x120+1G70)	2x(3x150+1G95)		2x(3x185+1G95)		2x(3x240+1G120)
Suggested line protection	(5)		NH2gG 400A	NH3gG 500A	NH3gG 630A		NH4gG 700A		NH4gG 800A

- (1) Data regarding the unit without accessories working in maximum power absorption conditions
- (2) Data referred to the unit without accessories operating at standard conditions: water inlet/outlet temperature from the source heat exchanger 30/35°C, water inlet/outlet temperature from the user heat exchanger 12/7°C.
- (3) Maximum effective RMS value of the current when the last compressor starts (FLA of the entire unit - FLA of the largest compressor + LRA of the largest compressor)
- (4) These values are determined for cables with operating temperature of 40°C, EPR insulation and a line with a maximum length of 50m. The line section must be determined by a qualified technician based on the protection devices, the length of the line, the type of cable used and the type of installation.
- (5) The correct line protection part must be determined by a qualified technician based on the length of the line, the type of cable used and the type of installation.

OMEGA SKY OH

			43.1	50.1	58.1	66.1	70.1	79.1	63.2
General electrical specifications									
Max. absorbed power (FLI)	(1)	kW	170	198	221	250	286	262	278
Max. absorbed current (FLA)	(1)	A	278	321	359	403	463	427	456
Rated current (Inom)	(2)	A	178	200	225	250	285	306	267
cosφ standard unit	(2)		0,88	0,88	0,88	0,89	0,89	0,88	0,88
Nominal current with power factor correction (Inom)	(2)	A	164	184	207	230	262	281	245
cosφ unit with power factor correction	(2)		0,98	0,98	0,97	0,97	0,97	0,96	0,97
Max. inrush current (MIC)	(3)	A	586	650	805	805	917	917	599
Power supply		V/ph/Hz	400V / 3ph / 50Hz						
Power supply for auxiliary circuits		V/ph/Hz	230V-24V / 1ph / 50Hz						
Suggested line section	(4)	mm ²	3x150+1G97	3x240+1G120	2x(3x120+1G70)	2x(3x150+1G95)			
Suggested line protection	(5)		NH2gG 315A	NH2gG 400A	NH3gG 500A	NH3gG 630A			
			72.2	88.2	101.2	116.2	132.2	143.2	159.2
General electrical specifications									
Max. absorbed power (FLI)	(1)	kW	311	340	395	442	500	572	524
Max. absorbed current (FLA)	(1)	A	524	556	642	718	806	926	854
Rated current (Inom)	(2)	A	326	356	400	450	500	570	612
cosφ standard unit	(2)		0,86	0,88	0,88	0,88	0,89	0,89	0,88
Nominal current with power factor correction (Inom)	(2)	A	300	327	368	414	460	524	563
cosφ unit with power factor correction	(2)		0,98	0,98	0,98	0,97	0,97	0,97	0,96
Max. inrush current (MIC)	(3)	A	656	864	971	1164	1208	1380	1344
Power supply		V/ph/Hz	400V / 3ph / 50Hz						
Power supply for auxiliary circuits		V/ph/Hz	230V-24V / 1ph / 50Hz						
Suggested line section	(4)	mm ²	2x(3x150+1G95)	2x(3x185+1G95)	2x(3x240+1G120)	3x(3x185+1G95)	3x(3x240+1G120)	3x(3x185+1G95)	
Suggested line protection	(5)		NH3gG 630A	NH4gG 700A	NH4gG 800A	NH4gG 1000A	NH4gG 1250A	NH4gG 1000A	

- (1) Data regarding the unit without accessories working in maximum power absorption conditions
- (2) Data referred to the unit without accessories operating at standard conditions: water inlet/outlet temperature from the source heat exchanger 30/35°C, water inlet/outlet temperature from the user heat exchanger 12/7°C.
- (3) Maximum effective RMS value of the current when the last compressor starts (FLA of the entire unit - FLA of the largest compressor + LRA of the largest compressor)
- (4) These values are determined for cables with operating temperature of 40°C, EPR insulation and a line with a maximum length of 50m. The line section must be determined by a qualified technician based on the protection devices, the length of the line, the type of cable used and the type of installation.
- (5) The correct line protection part must be determined by a qualified technician based on the length of the line, the type of cable used and the type of installation.

OMEGA SKY LC

		43.1	50.1	58.1	66.1	70.1	79.1	63.2	
General electrical specifications									
Max. absorbed power (FLI)	(1)	kW	149	167	193	218	241	232	
Max. absorbed current (FLA)	(1)	A	240	266	313	353	389	381	
Rated current (Inom)	(2)	A	177	193	232	260	286	277	
cosφ standard unit	(2)		0,88	0,89	0,87	0,88	0,87	0,85	
Nominal current with power factor correction (Inom)	(2)	A	163	179	210	238	262	246	
cosφ unit with power factor correction	(2)		0,96	0,96	0,96	0,96	0,95	0,95	
Max. inrush current (MIC)	(3)	A	436	465	586	650	805	505	
Power supply		V/ph/Hz	400V / 3ph / 50Hz						
Power supply for auxiliary circuits		V/ph/Hz	230V-24V / 1ph / 50Hz						
Suggested line section	(4)	mm ²	3x150 + 1G95	3x150 + 1G95	3x240 + 1G120	3x240 + 1G120	2x (3x120 + 1G70)	2x (3x120 + 1G70)	2x (3x120 + 1G70)
Suggested line protection	(5)		NH2gG 315A	NH2gG 315A	NH2gG 400A	NH2gG 400A	NH3gG 500A	NH3gG 500A	NH3gG 500A

		72.2	88.2	101.2	116.2	132.2	143.2	159.2	
General electrical specifications									
Max. absorbed power (FLI)	(1)	kW	259	297	334	385	436	524	
Max. absorbed current (FLA)	(1)	A	424	480	532	626	706	854	
Rated current (Inom)	(2)	A	312	354	386	464	520	632	
cosφ standard unit	(2)		0,85	0,88	0,89	0,87	0,88	0,87	
Nominal current with power factor correction (Inom)	(2)	A	277	326	359	423	480	579	
cosφ unit with power factor correction	(2)		0,96	0,96	0,96	0,95	0,95	0,95	
Max. inrush current (MIC)	(3)	A	553	676	731	899	1.003	1.194	
Power supply		V/ph/Hz	400V / 3ph / 50Hz						
Power supply for auxiliary circuits		V/ph/Hz	230V-24V / 1ph / 50Hz						
Suggested line section	(4)	mm ²	2x (3x120 + 1G70)	2x (3x150 + 1G95)	2x (3x150 + 1G95)	2x (3x185 + 1G95)	2x (3x240 + 1G120)	2x (3x240 + 1G120)	4x (3x120 + 1G70)
Suggested line protection	(5)		NH3gG 500A	NH3gG 630A	NH3gG 630A	NH4gG 700A	NH4gG 800A	NH4gG 800A	NH4gG 1000A

- (1) Data regarding the unit without accessories working in maximum power absorption conditions
- (2) Data referred to the unit without accessories operating at standard conditions: condensing temperature 50°C, water inlet/outlet temperature from the user heat exchanger 12/7°C.
- (3) Maximum effective RMS value of the current when the last compressor starts (FLA of the entire unit - FLA of the largest compressor + LRA of the largest compressor)
- (4) These values are determined for cables with operating temperature of 40°C, EPR insulation and a line with a maximum length of 50m. The line section must be determined by a qualified technician based on the protection devices, the length of the line, the type of cable used and the type of installation.
- (5) The correct line protection part must be determined by a qualified technician based on the length of the line, the type of cable used and the type of installation.

FLOW RATE RANGES OF HEAT EXCHANGERS

The units are sized and optimized for the following nominal conditions:

- inlet-outlet of the source-side heat exchanger 30/35°C
- inlet-outlet of the user-side heat exchanger 12/7°C

The units can work at design conditions different from nominal conditions, provided that:

- the design condition falls within the operating limits specified below
- the unit is equipped with all the accessories necessary for operation of the unit (e.g. brine kit, condensation control)
- the flow rate at design conditions (that is, of the specific application) must always come within the allowed flow rate ranges specified below. If the design conditions require a water flow rate that does not come within the allowed operating range, you must contact our sales department that will identify the most suitable solution for the specific application.

OMEGA SKY R513A

	Evaporator		Condenser	
	Qmin	Qmax	Qmin	Qmax
	m ³ /h	m ³ /h	m ³ /h	m ³ /h
43.1	38,3	114,8	45,6	136,7
50.1	43,9	131,7	52,2	156,5
58.1	50,3	150,8	59,5	178,6
66.1	56,9	170,7	67,4	202,2
70.1	62,2	186,7	74,1	222,2
79.1	68,4	205,3	81,6	244,8
63.2	55,6	166,9	66,1	198,4
72.2	63,2	189,6	75,2	225,5
88.2	76,3	228,9	90,9	272,8
101.2	88,0	263,9	104,5	313,5
116.2	101,5	304,4	120,1	360,2
132.2	115,2	345,7	136,3	409,0
143.2	124,4	373,3	148,1	444,4
159.2	137,0	411,0	163,3	490,0

OMEGA SKY R134a

	Evaporator		Condenser	
	Qmin	Qmax	Qmin	Qmax
	m ³ /h	m ³ /h	m ³ /h	m ³ /h
43.1	37,1	111,4	44,0	132,1
50.1	42,7	128,0	50,5	151,4
58.1	48,8	146,3	57,5	172,6
66.1	55,3	165,8	65,2	195,7
70.1	60,2	180,6	71,4	214,2
79.1	66,6	199,7	79,0	237,1
63.2	53,9	161,7	63,8	191,5
72.2	61,3	183,9	72,6	217,9
88.2	74,0	222,1	87,9	263,6
101.2	85,5	256,4	101,1	303,4
116.2	98,5	295,4	116,0	348,1
132.2	112,1	336,4	132,1	396,2
143.2	120,5	361,5	142,9	428,8
159.2	133,0	399,1	158,0	473,9

OMEGA SKY LC R513A

	Evaporator	
	Qmin	Qmax
	m ³ /h	m ³ /h
43.1	32,7	98,2
50.1	37,9	113,8
58.1	44,1	132,4
66.1	50,1	150,2
70.1	54,4	163,1
79.1	59,3	177,9
63.2	48,7	146,1
72.2	55,3	166,0
88.2	65,3	195,9
101.2	76,1	228,3
116.2	89,2	267,6
132.2	101,7	305,1
143.2	108,9	326,6
159.2	118,5	355,5

OMEGA SKY LC R134a

	Evaporator	
	Qmin	Qmax
	m ³ /h	m ³ /h
43.1	32,5	97,6
50.1	38,1	114,4
58.1	43,7	131,2
66.1	49,6	148,9
70.1	53,9	161,6
79.1	58,8	176,5
63.2	48,3	145,0
72.2	55,1	165,2
88.2	64,9	194,7
101.2	76,5	229,5
116.2	88,4	265,2
132.2	100,8	302,4
143.2	107,8	323,5
159.2	117,6	352,8

OPERATING LIMITS

Omega Sky

COOLING & TOTAL RECOVERY

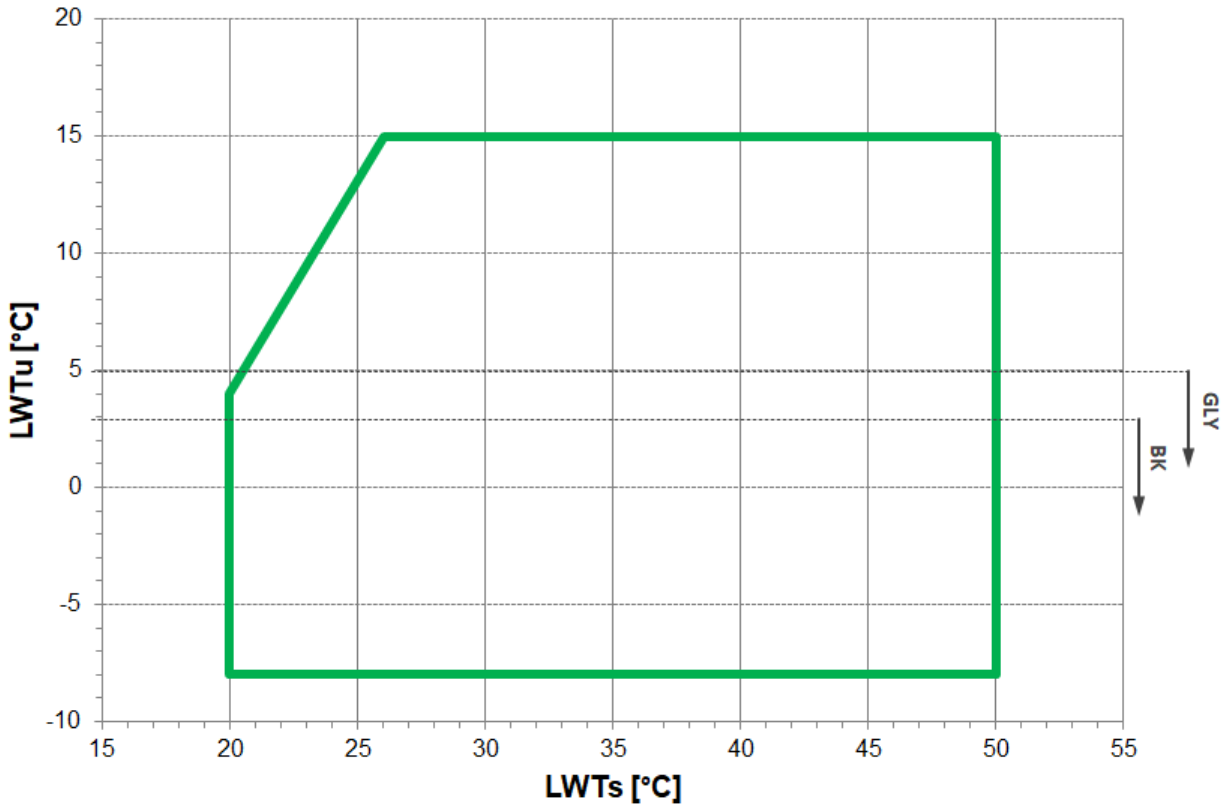

LWTs: water outlet temperature from the source-side heat exchanger

LWTu: water outlet temperature from the user-side heat exchanger

LWTr: water outlet temperature from the recovery exchanger

BK: For LWTu lower or equal to +3°C, it is mandatory to fit the "Brine Kit" accessory

For LWTu below +5°C, it is compulsory to use suitable percentages of antifreeze additives (glycols) to prevent ice formation in the exchanger.

The inlet and outlet temperatures of the user-side exchanger must be given on ordering to allow correct setting of the alarm parameters and verification of the sizing of the expansion valve.

The cooling set point can then be changed by the customer in an interval that, compared to the set point given on ordering, ranges from -1K up to the maximum temperature allowed by the above-stated operating limits.

The unit will be optimized to work at the set point temperatures given on ordering. For different set points, the cooling capacity provided and the level of efficiency of the machine could decrease and move away from these conditions.

Omega Sky OH

HEATING (EXCLUDED SIZES 79.1 AND 159.2)

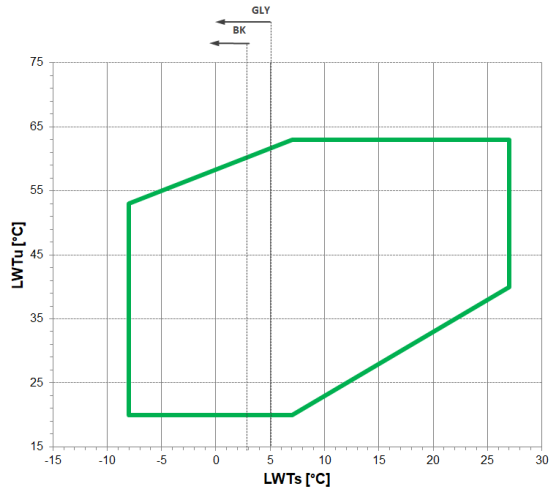

HEATING (ONLY FOR SIZES 79.1 AND 159.2)

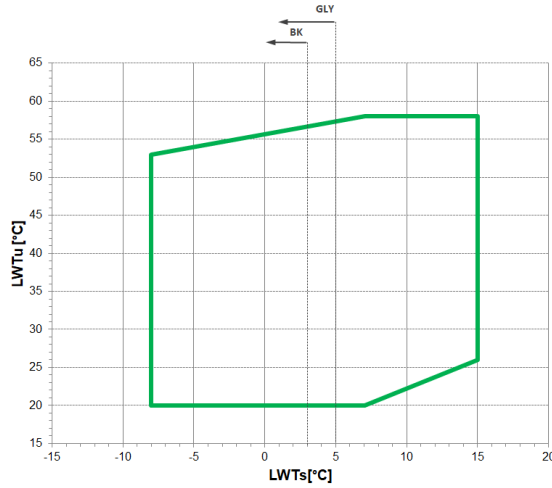

- LWTs:** water outlet temperature from the source-side heat exchanger
- LWTu:** water outlet temperature from the user-side heat exchanger
- LWTr:** water outlet temperature from the recovery exchanger
- BK:** For LWTu lower or equal to +3°C, it is mandatory to fit the "Brine Kit" accessory

For LWTu below +5°C, it is compulsory to use suitable percentages of antifreeze additives (glycols) to prevent ice formation in the exchanger.

The inlet and outlet temperatures of the user-side exchanger must be given on ordering to allow correct setting of the alarm parameters and verification of the sizing of the expansion valve.

The cooling set point can then be changed by the customer in an interval that, compared to the set point given on ordering, ranges from -1K up to the maximum temperature allowed by the above-stated operating limits.

The unit will be optimized to work at the set point temperatures given on ordering. For different set points, the cooling capacity provided and the level of efficiency of the machine could decrease and move away from these conditions.

Omega Sky HPW

COOLING

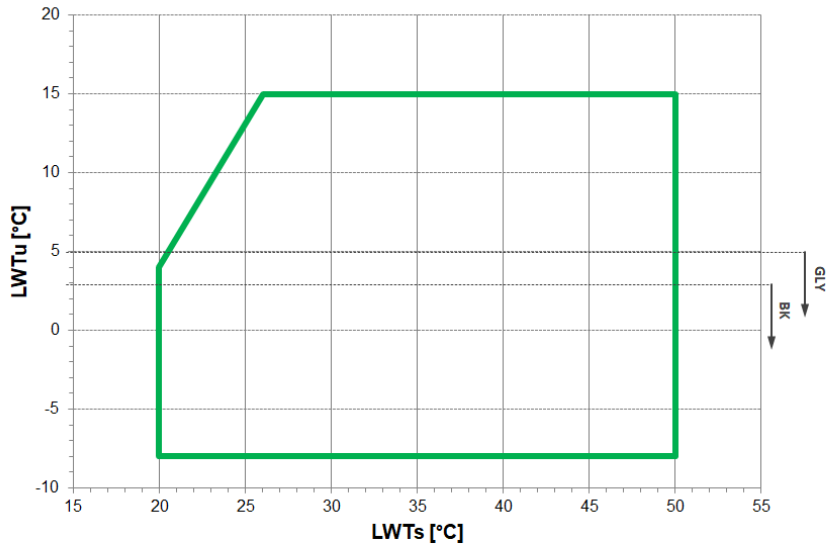

HEATING

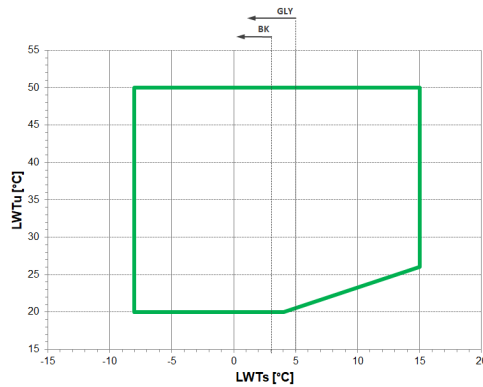

- LWTs:** water outlet temperature from the source-side heat exchanger
- LWTu:** water outlet temperature from the user-side heat exchanger
- BK:** For LWTu lower or equal to +3°C, it is mandatory to fit the "Brine Kit" accessory

For LWTu below +5°C, it is compulsory to use suitable percentages of antifreeze additives (glycols) to prevent ice formation in the exchanger.

The inlet and outlet temperatures of the user-side exchanger must be given on ordering to allow correct setting of the alarm parameters and verification of the sizing of the expansion valve.

The cooling set point can then be changed by the customer in an interval that, compared to the set point given on ordering, ranges from -1K up to the maximum temperature allowed by the above-stated operating limits.

The unit will be optimized to work at the set point temperatures given on ordering. For different set points, the cooling capacity provided and the level of efficiency of the machine could decrease and move away from these conditions.

Omega Sky LC

COOLING

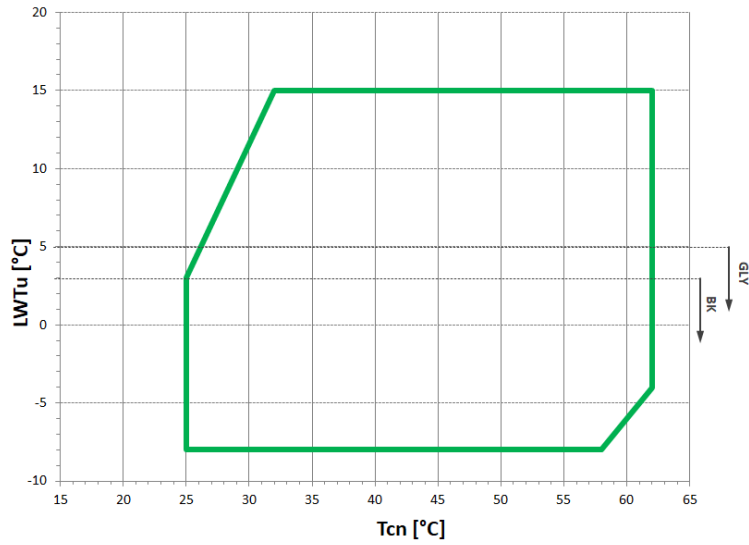

TOTAL RECOVERY

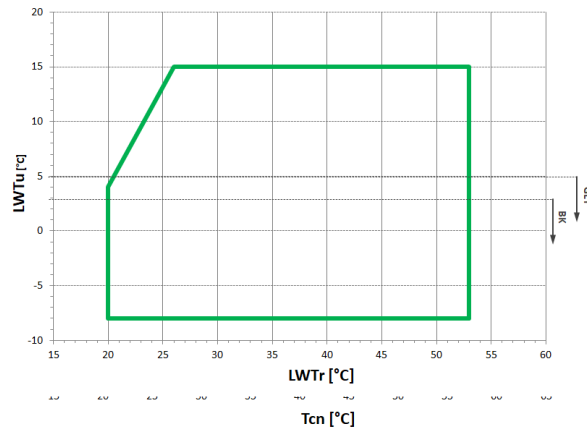

Tcn: condensing temperature

LWTu: water outlet temperature from the user-side heat exchanger

LWTr: water outlet temperature from the recovery exchanger

BK: For LWTu lower or equal to +3°C, it is mandatory to fit the "Brine Kit" accessory

For LWTu below +5°C, it is compulsory to use suitable percentages of antifreeze additives (glycols) to prevent ice formation in the exchanger.

The inlet and outlet temperatures of the user-side exchanger must be given on ordering to allow correct setting of the alarm parameters and verification of the sizing of the expansion valve.

The cooling set point can then be changed by the customer in an interval that, compared to the set point given on ordering, ranges from -1K up to the maximum temperature allowed by the above-stated operating limits.

The unit will be optimized to work at the set point temperatures given on ordering. For different set points, the cooling capacity provided and the level of efficiency of the machine could decrease and move away from these conditions.

NOISE LEVELS

OMEGA SKY

	Octave bands [dB]																Total [dB(A)]	
	63 Hz		125 Hz		250 Hz		500 Hz		1000 Hz		2000 Hz		4000 Hz		8000 Hz		Lw_tot	Lp_tot
	Lw	Lp	Lw	Lp	Lw	Lp	Lw	Lp	Lw	Lp	Lw	Lp	Lw	Lp	Lw	Lp		
43.1	63	45	74	55	88	69	88	70	88	69	81	62	79	60	66	47	91	73
50.1	64	45	75	56	88	69	89	70	88	69	81	62	76	57	66	47	91	72
58.1	71	53	62	44	90	72	88	69	90	71	82	63	73	54	63	45	92	74
66.1	93	74	86	68	83	65	93	74	89	70	83	65	73	54	66	48	93	75
70.1	66	47	76	57	88	70	92	74	91	72	85	67	71	53	52	33	94	76
79.1	71	52	65	47	89	70	93	75	92	74	84	66	72	54	59	41	95	77
63.2	63	44	66	47	86	67	93	74	90	71	85	66	71	52	63	44	94	75
72.2	59	40	69	50	85	66	91	72	91	72	87	68	70	51	57	38	94	75
88.2	66	47	77	57	90	71	91	72	91	71	84	64	82	62	69	49	94	75
101.2	67	48	78	58	91	71	92	72	91	71	84	65	79	60	69	50	94	75
116.2	74	55	65	46	93	74	91	71	93	73	84	65	76	56	66	47	95	76
132.2	96	76	89	70	86	67	96	76	92	72	86	67	76	56	69	50	96	77
143.2	69	50	79	59	91	72	95	76	94	74	88	69	74	55	55	36	97	78
159.2	74	54	68	49	92	72	96	77	95	76	87	68	75	56	62	43	98	79

OMEGA SKY LN

	Octave bands [dB]																Total [dB(A)]	
	63 Hz		125 Hz		250 Hz		500 Hz		1000 Hz		2000 Hz		4000 Hz		8000 Hz		Lw_tot	Lp_tot
	Lw	Lp	Lw	Lp	Lw	Lp	Lw	Lp	Lw	Lp	Lw	Lp	Lw	Lp	Lw	Lp		
43.1	60	41	69	51	82	64	83	65	83	64	76	58	74	56	62	43	86	68
50.1	60	41	71	52	83	64	84	65	83	64	77	58	72	53	63	44	86	67
58.1	67	49	59	40	85	66	83	64	85	66	77	58	69	50	60	41	87	69
66.1	88	69	81	63	78	60	88	69	84	65	79	60	69	50	63	44	88	70
70.1	62	44	71	53	84	65	87	69	86	67	81	62	67	49	49	31	89	71
79.1	67	48	62	43	84	65	88	70	87	69	80	61	68	50	56	37	90	72
63.2	60	41	63	44	81	62	88	69	85	66	80	61	67	48	60	41	89	70
72.2	55	36	65	46	80	61	86	67	86	67	82	63	66	47	54	35	89	70
88.2	63	43	72	53	85	66	86	67	86	66	79	60	77	58	65	45	89	70
101.2	63	44	74	54	86	66	87	67	86	66	80	60	75	55	66	46	89	70
116.2	70	51	62	42	88	68	86	66	88	68	80	60	72	52	63	43	90	71
132.2	90	71	84	65	81	62	91	71	87	67	82	62	72	52	66	46	91	72
143.2	65	46	74	55	86	67	90	71	89	69	84	64	70	51	52	33	92	73
159.2	70	50	65	45	87	67	91	72	90	71	83	63	71	52	59	39	93	74

Reference conditions: source-side heat exchanger input/output water temperature 30/35°C; user-side heat exchanger input/output water temperature 12/7°C; unit operating at rated capacity, without any option.

Lw: sound power levels.

Values obtained from measures taken according to standard ISO 3744.

Lw_tot is the only binding value.

Lp: sound pressure levels calculated from sound power levels, related to distance of 1 m from the unit in free field with directivity factor Q=2. Non-binding values.

The acoustic data are related to standard conditions in referable and reproducible operating conditions. All data with the exception of Lw_tot are provided for illustrative purposes only and can not be used for forecasting purposes or for the verification of binding limits.

With special reference to noise emissions, the Manufacturer takes liability for their conformity, limited to the declared Lw_tot value. Any and all other Manufacturer's liability for the impact of such emissions in relation to the location of the machine and other conditions related to machine installation is excluded. The environment and the installation conditions, as well as the operating modes, can alter the sound emissions. Any assessment concerning these conditions falls within the area of competence of the plant designer and/or the fitter.

OMEGA SKY XLN

	Octave bands [dB]																Total [dB(A)]	
	63 Hz		125 Hz		250 Hz		500 Hz		1000 Hz		2000 Hz		4000 Hz		8000 Hz		Lw_tot	Lp_tot
	Lw	Lp	Lw	Lp	Lw	Lp	Lw	Lp	Lw	Lp	Lw	Lp	Lw	Lp	Lw	Lp		
43.1	57	39	67	48	79	61	80	62	80	61	73	55	71	53	59	41	83	65
50.1	58	39	68	49	80	61	81	62	79	60	74	55	69	50	60	41	83	64
58.1	65	46	57	38	82	63	80	61	82	63	74	56	66	48	57	39	84	66
66.1	84	66	79	60	76	57	85	66	81	62	76	57	66	48	61	42	85	67
70.1	60	42	69	50	81	62	84	66	83	64	78	59	65	46	47	29	86	68
79.1	65	46	60	41	81	62	85	67	84	66	77	58	66	47	54	36	87	69
63.2	58	39	61	42	78	59	85	66	82	63	77	58	65	46	57	38	86	67
72.2	53	34	62	43	78	59	83	64	83	64	79	60	64	45	52	33	86	67
88.2	60	41	70	50	82	63	83	63	83	63	76	57	74	55	62	43	86	67
101.2	61	42	71	51	83	63	84	64	82	63	77	57	72	53	63	44	86	67
116.2	68	48	60	40	85	65	83	63	85	65	77	58	69	50	60	41	87	68
132.2	87	68	82	62	79	59	88	68	84	64	79	59	69	50	63	44	88	69
143.2	63	44	72	52	84	64	87	67	86	66	81	61	68	48	50	31	89	70
159.2	68	48	62	43	84	64	88	69	87	68	80	60	69	49	57	38	90	71

Reference conditions: source-side heat exchanger input/output water temperature 30/35°C; user-side heat exchanger input/output water temperature 12/7°C; unit operating at rated capacity, without any option.

Lw: sound power levels.

Values obtained from measures taken according to standard ISO 3744.

Lw_tot is the only binding value.

Lp: sound pressure levels calculated from sound power levels, related to distance of 1 m from the unit in free field with directivity factor Q=2. Non-binding values.

The acoustic data are related to standard conditions in referable and reproducible operating conditions. All data with the exception of Lw_tot are provided for illustrative purposes only and can not be used for forecasting purposes or for the verification of binding limits.

With special reference to noise emissions, the Manufacturer takes liability for their conformity, limited to the declared Lw_tot value. Any and all other Manufacturer's liability for the impact of such emissions in relation to the location of the machine and other conditions related to machine installation is excluded. The environment and the installation conditions, as well as the operating modes, can alter the sound emissions. Any assessment concerning these conditions falls within the area of competence of the plant designer and/or the fitter.

OMEGA SKY OH

	Octave bands [dB]																Total [dB(A)]	
	63 Hz		125 Hz		250 Hz		500 Hz		1000 Hz		2000 Hz		4000 Hz		8000 Hz		Lw_tot	Lp_tot
	Lw	Lp	Lw	Lp	Lw	Lp	Lw	Lp	Lw	Lp	Lw	Lp	Lw	Lp	Lw	Lp		
43.1	74	55	87	69	93	75	91	72	93	75	85	66	79	61	67	49	96	78
50.1	72	53	85	66	95	77	92	74	93	74	86	67	77	58	66	48	96	77
58.1	73	54	83	64	99	81	94	76	92	73	88	69	69	50	60	41	97	79
66.1	72	54	84	66	98	80	94	75	95	77	88	69	78	59	67	48	98	80
70.1	80	61	84	65	97	79	93	75	97	79	87	68	77	59	68	49	99	81
79.1	78	60	76	57	94	76	96	78	96	78	88	70	80	61	66	47	99	81
63.2	70	51	75	56	88	69	94	75	96	77	91	72	73	54	62	44	98	79
72.2	79	60	79	61	86	68	95	77	95	76	89	71	74	55	64	45	98	79
88.2	77	57	90	72	96	78	94	75	96	78	88	69	82	64	70	52	99	80
101.2	75	55	88	69	98	80	95	77	96	77	89	70	80	61	69	51	99	80
116.2	76	56	86	67	102	84	97	79	95	76	91	72	72	53	63	44	100	81
132.2	75	56	87	69	101	83	97	78	98	80	91	72	81	62	70	51	101	82
143.2	83	63	87	68	100	82	96	78	100	82	90	71	80	62	71	52	102	83
159.2	81	62	79	60	97	79	99	81	99	81	91	73	83	64	69	50	102	83

OMEGA SKY OH LN

	Octave bands [dB]																Total [dB(A)]	
	63 Hz		125 Hz		250 Hz		500 Hz		1000 Hz		2000 Hz		4000 Hz		8000 Hz		Lw_tot	Lp_tot
	Lw	Lp	Lw	Lp	Lw	Lp	Lw	Lp	Lw	Lp	Lw	Lp	Lw	Lp	Lw	Lp		
43.1	69	50	82	64	88	70	86	67	88	70	80	61	74	56	62	44	91	73
50.1	67	48	80	61	90	71	87	68	88	69	81	62	72	53	61	42	91	72
58.1	68	49	78	59	94	76	89	71	87	68	83	64	64	45	55	36	92	74
66.1	67	49	79	61	93	75	89	70	90	72	83	64	73	54	62	43	93	75
70.1	75	56	79	60	92	74	88	70	92	74	82	63	72	54	63	44	94	76
79.1	73	55	71	52	89	71	91	73	91	73	83	65	75	56	61	42	94	76
63.2	65	46	70	51	83	64	89	70	91	72	86	67	68	49	57	38	93	74
72.2	74	55	74	55	81	62	90	71	90	71	84	65	69	50	59	40	93	74
88.2	72	52	85	66	91	72	89	69	91	72	83	63	77	58	65	46	94	75
101.2	70	50	83	63	93	74	90	71	91	71	84	64	75	55	64	45	94	75
116.2	71	51	81	61	97	78	92	73	90	70	86	66	67	47	58	38	95	76
132.2	70	51	82	63	96	77	92	72	93	74	86	66	76	56	65	45	96	77
143.2	78	58	82	62	95	76	91	72	95	76	85	65	75	56	66	46	97	78
159.2	76	57	74	54	92	73	94	75	94	75	86	67	78	58	64	44	97	78

Reference conditions: source-side heat exchanger input/output water temperature 10/7°C; user-side heat exchanger input/output water temperature 47/55°C; unit operating at rated capacity, without any option.

Lw: sound power levels.

Values obtained from measures taken according to standard ISO 3744.

Lw_tot is the only binding value.

Lp: Values obtained from the sound power level, related to a distance of 1 m from the unit in free field with directivity factor Q=2. Non-binding values.

The acoustic data are related to standard conditions in referable and reproducible operating conditions. All data with the exception of Lw_tot are provided for illustrative purposes only and can not be used for forecasting purposes or for the verification of binding limits.

With special reference to noise emissions, the Manufacturer takes liability for their conformity, limited to the declared Lw_tot value. Any and all other Manufacturer's liability for the impact of such emissions in relation to the location of the machine and other conditions related to machine installation is excluded. The environment and the installation conditions, as well as the operating modes, can alter the sound emissions. Any assessment concerning these conditions falls within the area of competence of the plant designer and/or the fitter.

OMEGA SKY OH XLN

	Octave bands [dB]																Total [dB(A)]	
	63 Hz		125 Hz		250 Hz		500 Hz		1000 Hz		2000 Hz		4000 Hz		8000 Hz		Lw_tot	Lp_tot
	Lw	Lp	Lw	Lp	Lw	Lp	Lw	Lp	Lw	Lp	Lw	Lp	Lw	Lp	Lw	Lp		
43.1	66	47	79	61	85	67	83	64	85	67	77	58	71	53	59	41	88	70
50.1	64	45	77	58	87	68	84	65	85	66	78	59	69	50	58	39	88	69
58.1	65	46	75	56	91	73	86	68	84	65	80	61	61	42	52	33	89	71
66.1	64	46	76	58	90	72	86	67	87	69	80	61	70	51	59	40	90	72
70.1	72	53	76	57	89	71	85	67	89	71	79	60	69	51	60	41	91	73
79.1	70	52	68	49	86	68	88	70	88	70	80	62	72	53	58	39	91	73
63.2	62	43	67	48	80	61	86	67	88	69	83	64	65	46	54	35	90	71
72.2	71	52	71	52	78	59	87	68	87	68	81	62	66	47	56	37	90	71
88.2	69	49	82	63	88	69	86	66	88	69	80	60	74	55	62	43	91	72
101.2	67	47	80	60	90	71	87	68	88	68	81	61	72	52	61	42	91	72
116.2	68	48	78	58	94	75	89	70	87	67	83	63	64	44	55	35	92	73
132.2	67	48	79	60	93	74	89	69	90	71	83	63	73	53	62	42	93	74
143.2	75	55	79	59	92	73	88	69	92	73	82	62	72	53	63	43	94	75
159.2	73	54	71	51	89	70	91	72	91	72	83	64	75	55	61	41	94	75

Reference conditions: source-side heat exchanger input/output water temperature 10/7°C; user-side heat exchanger input/output water temperature 47/55°C; unit operating at rated capacity, without any option.

Lw: sound power levels.

Values obtained from measures taken according to standard ISO 3744.

Lw_tot is the only binding value.

Lp: Values obtained from the sound power level, related to a distance of 1 m from the unit in free field with directivity factor Q=2. Non-binding values.

The acoustic data are related to standard conditions in referable and reproducible operating conditions. All data with the exception of Lw_tot are provided for illustrative purposes only and can not be used for forecasting purposes or for the verification of binding limits.

With special reference to noise emissions, the Manufacturer takes liability for their conformity, limited to the declared Lw_tot value.

Any and all other Manufacturer's liability for the impact of such emissions in relation to the location of the machine and other conditions related to machine installation is excluded. The environment and the installation conditions, as well as the operating modes, can alter the sound emissions. Any assessment concerning these conditions falls within the area of competence of the plant designer and/or the fitter.

DIMENSIONAL DIAGRAMS

OMEGA SKY 43.1

DDIM000191

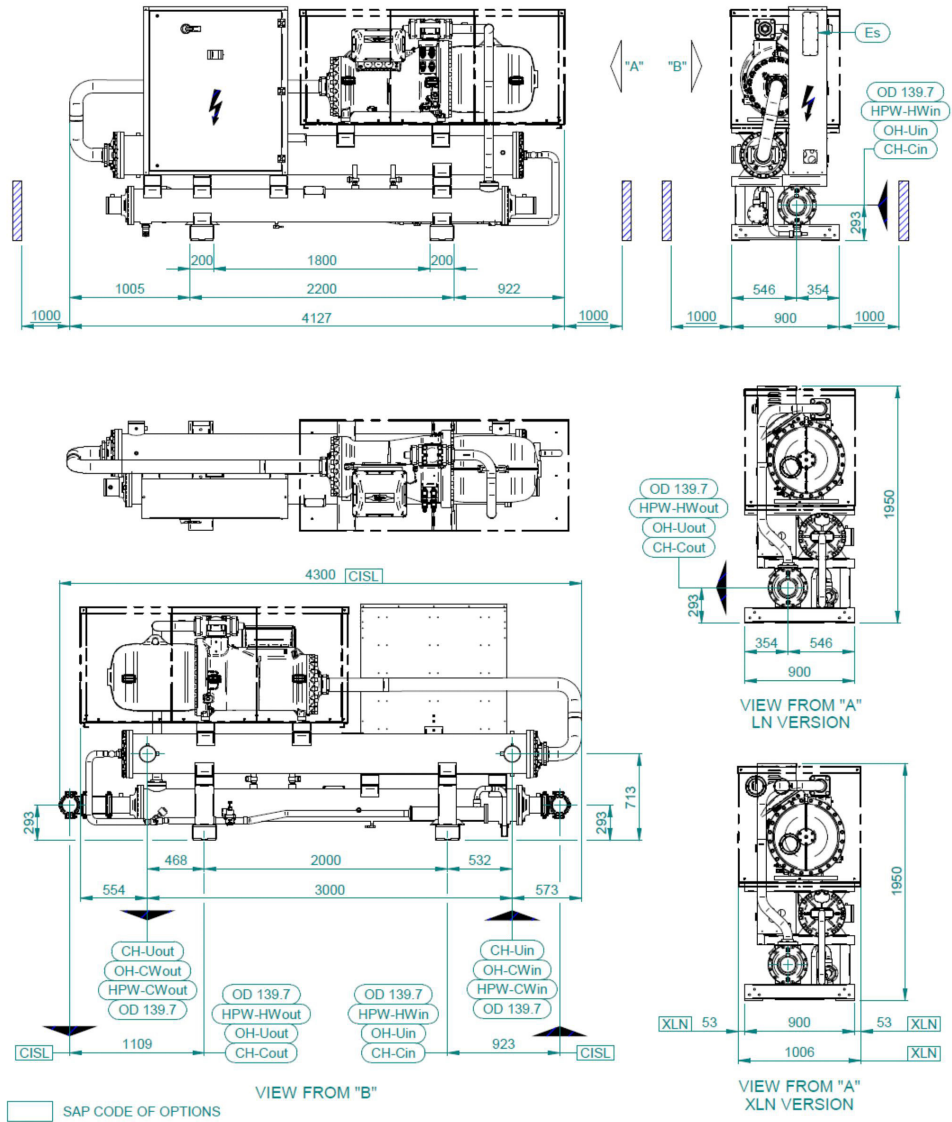

Note: These drawings are not contractually binding. For the installation design, refer to the specific dimensional drawing available on request.

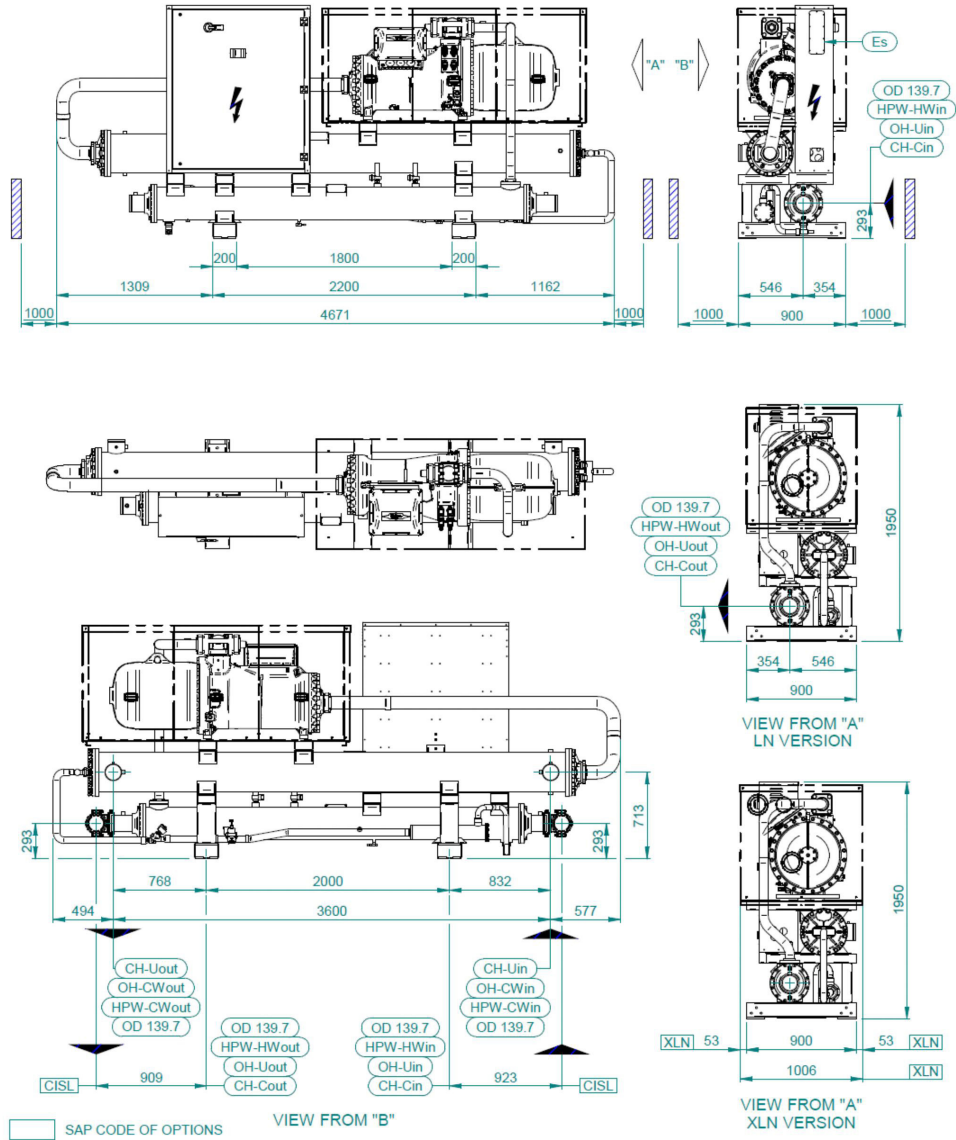

Note: These drawings are not contractually binding. For the installation design, refer to the specific dimensional drawing available on request.

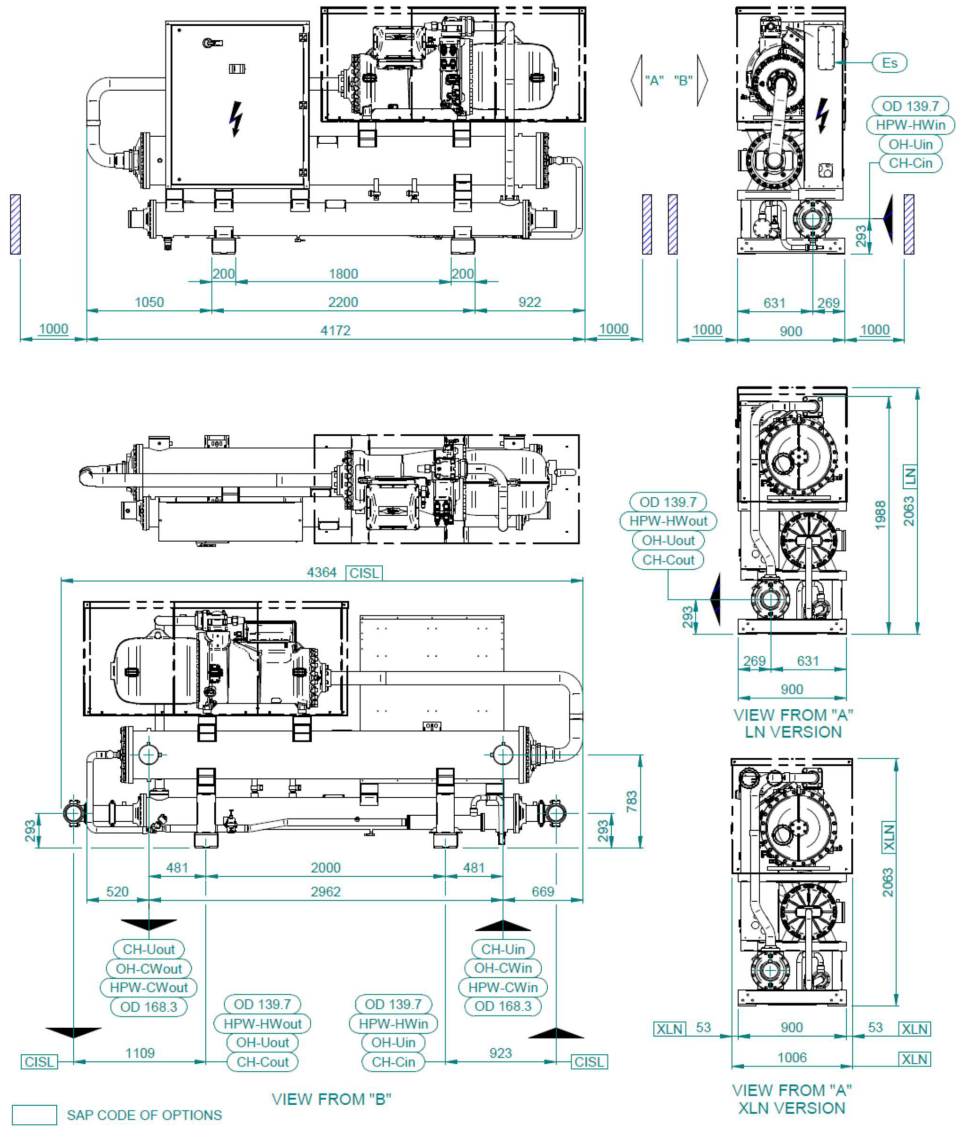

Note: These drawings are not contractually binding. For the installation design, refer to the specific dimensional drawing available on request.

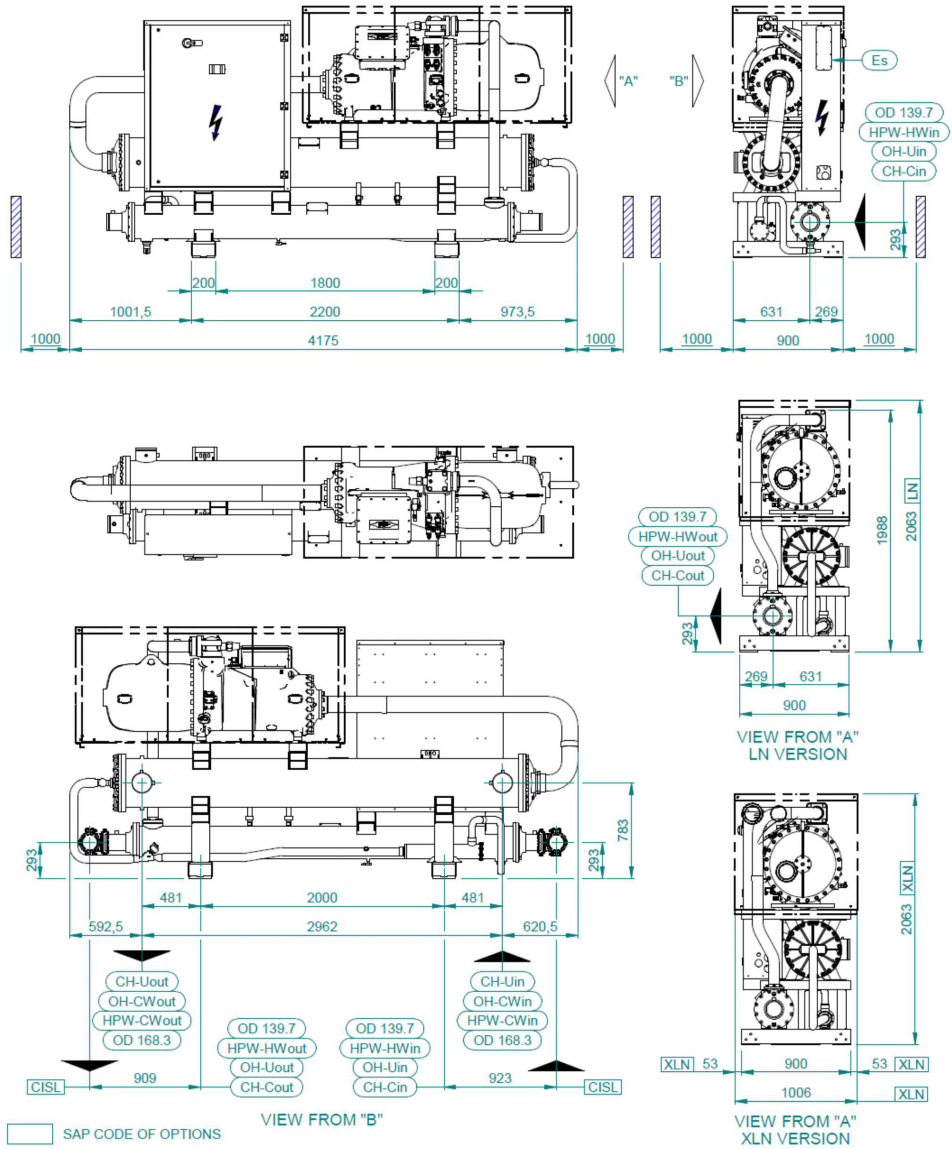

Note: These drawings are not contractually binding. For the installation design, refer to the specific dimensional drawing available on request.

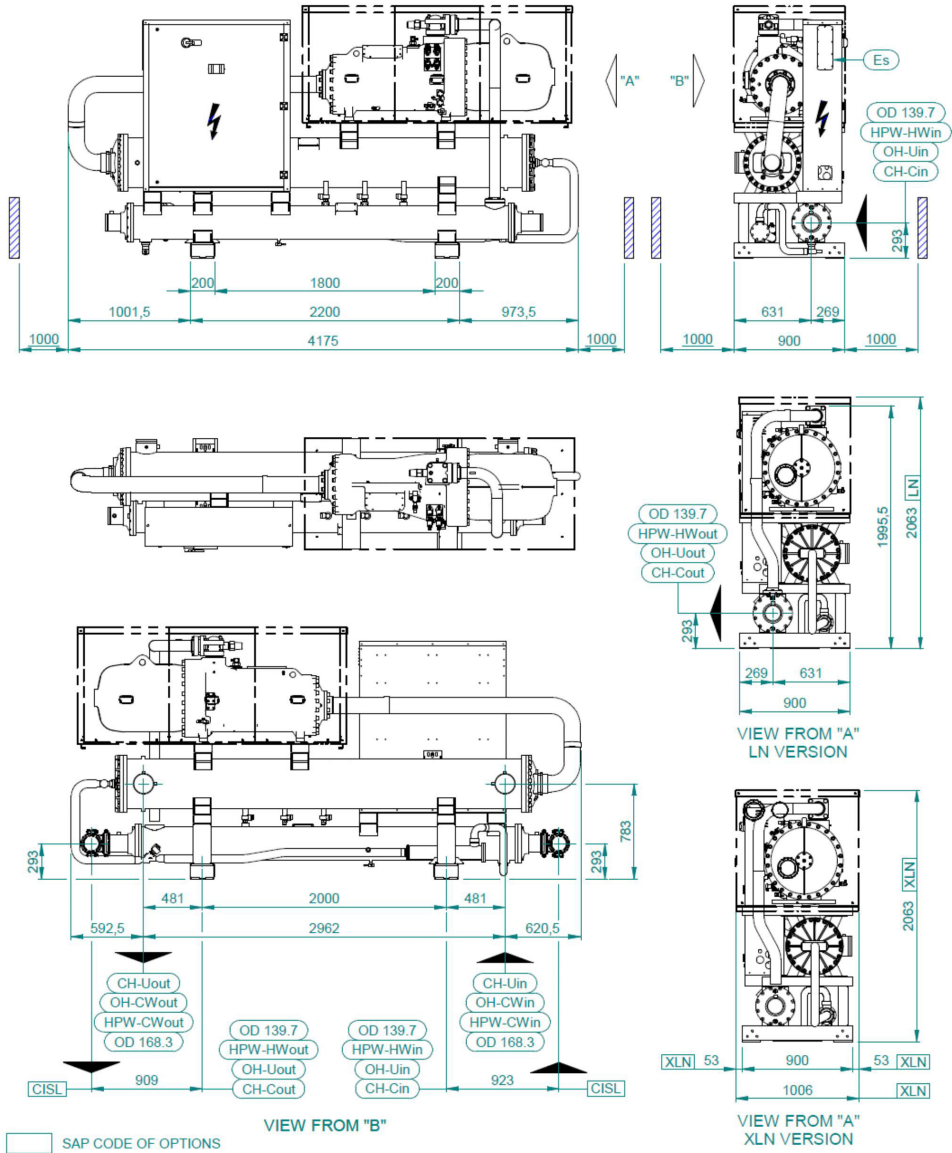

Note: These drawings are not contractually binding. For the installation design, refer to the specific dimensional drawing available on request.

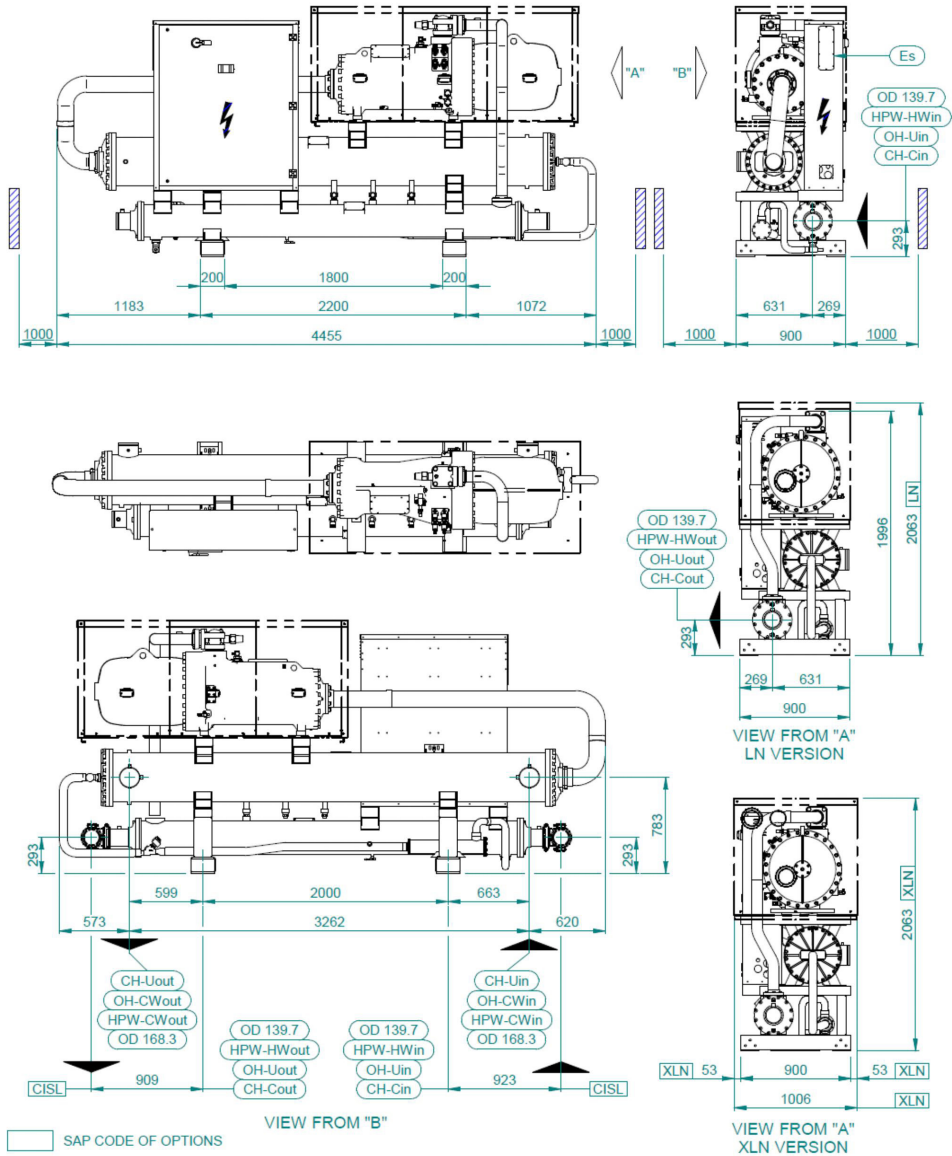

Note: These drawings are not contractually binding. For the installation design, refer to the specific dimensional drawing available on request.

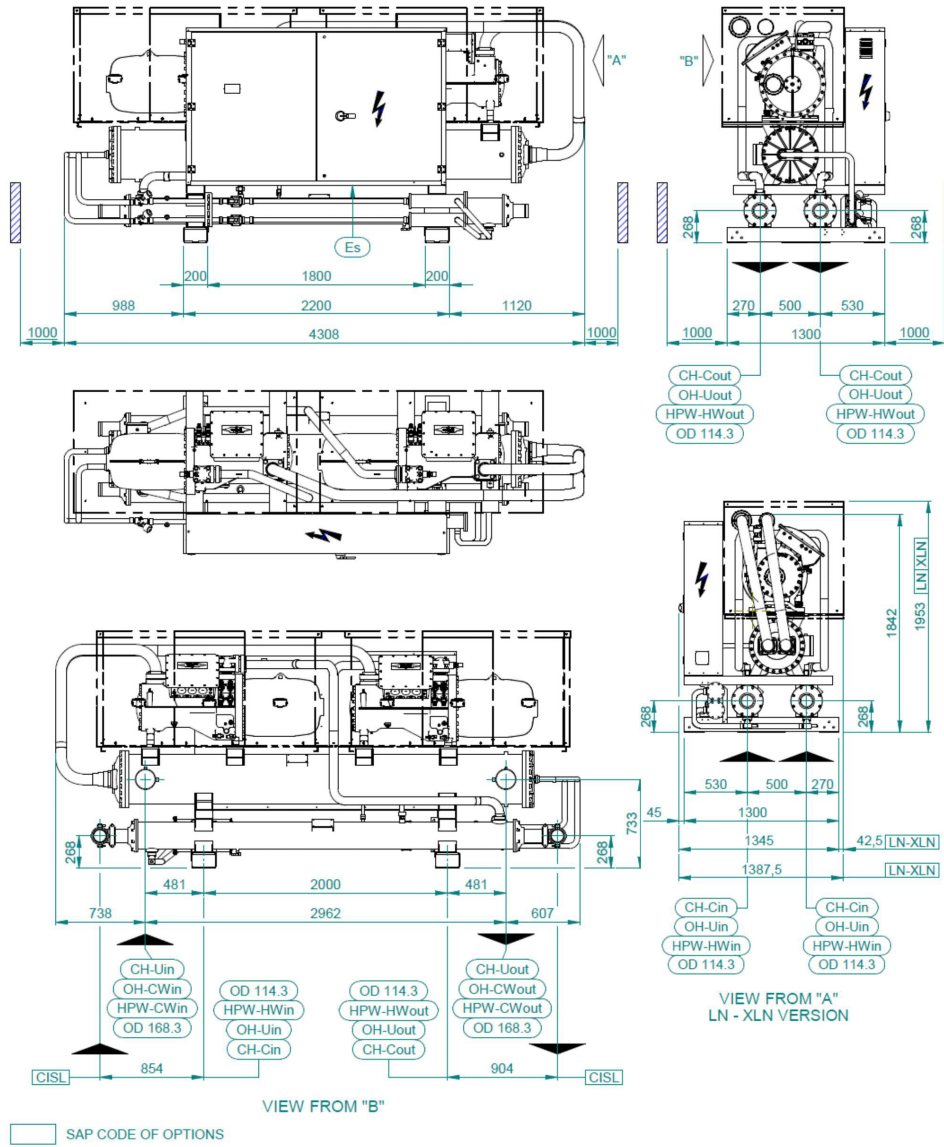

Note: These drawings are not contractually binding. For the installation design, refer to the specific dimensional drawing available on request.

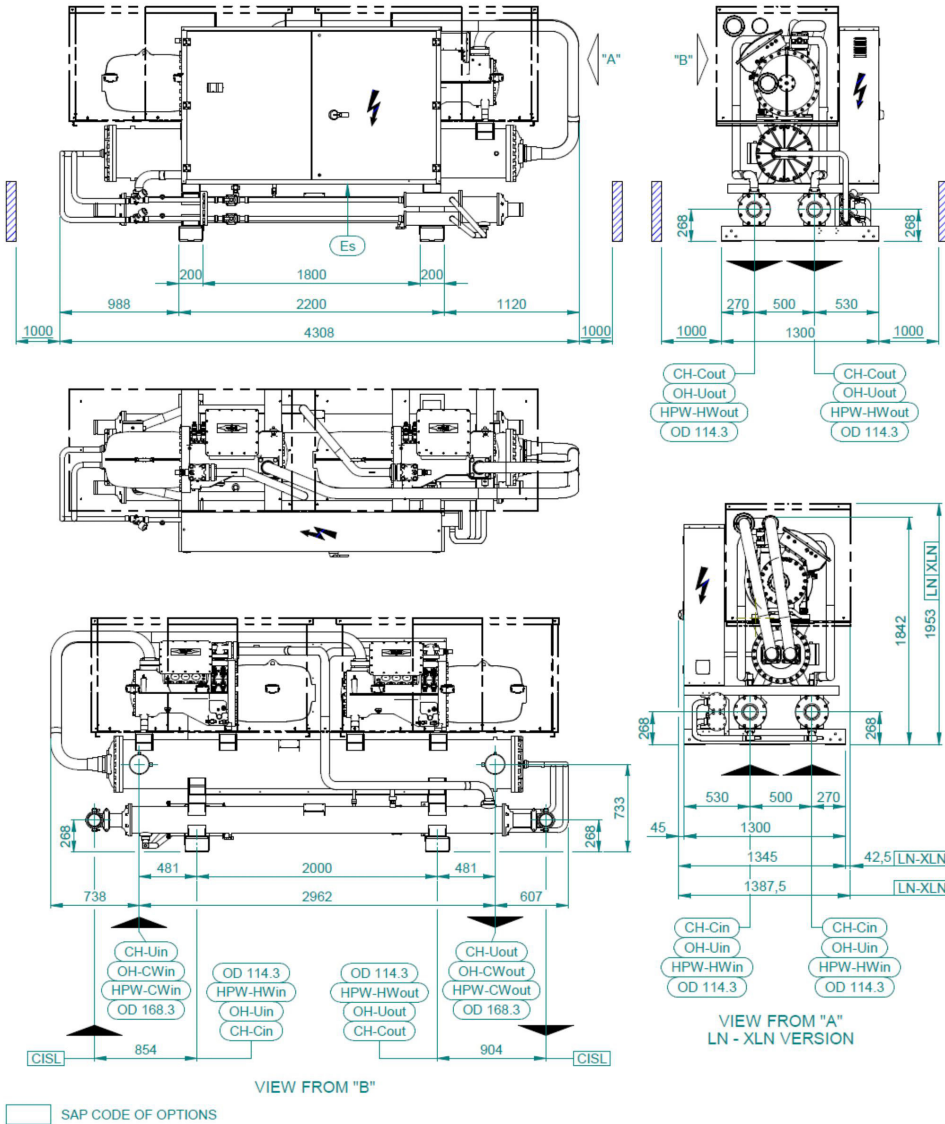

Note: These drawings are not contractually binding. For the installation design, refer to the specific dimensional drawing available on request.

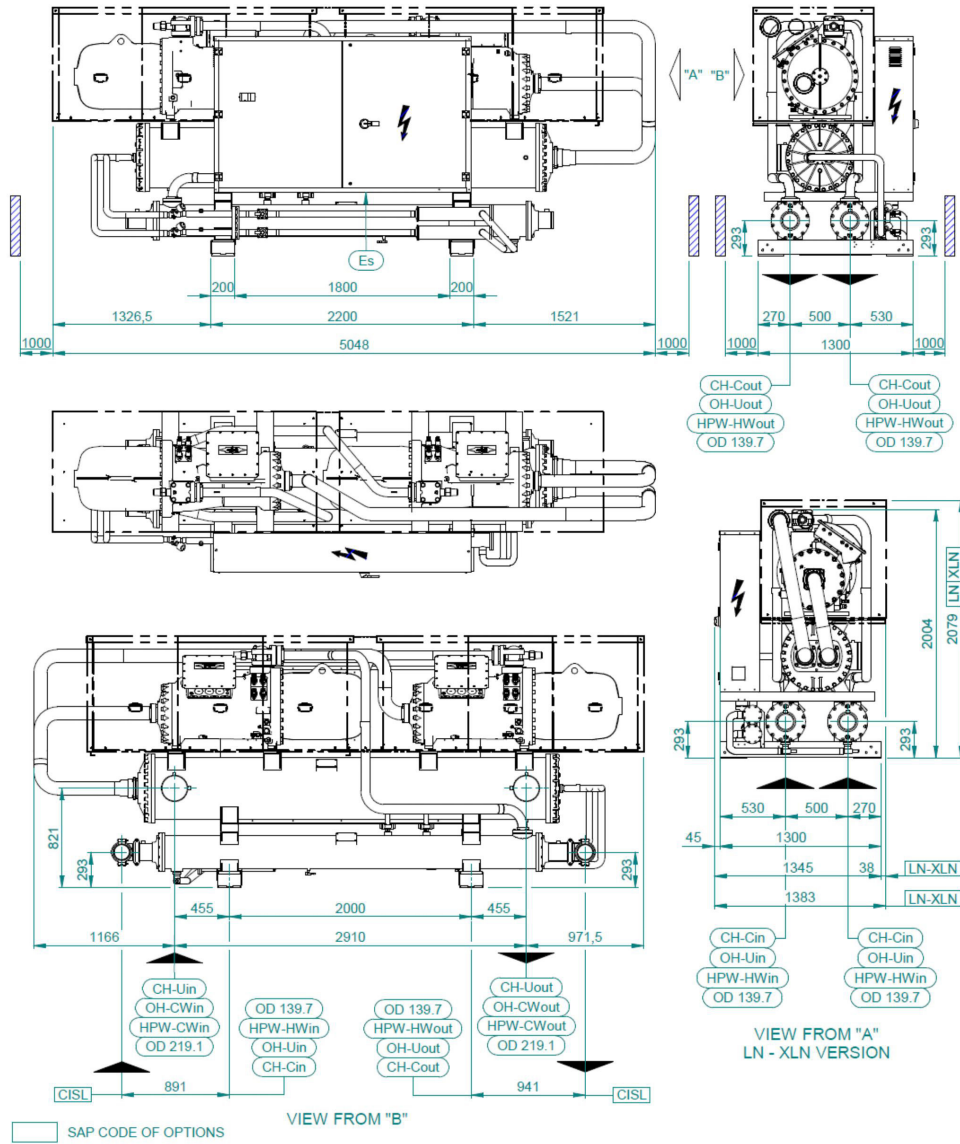

Note: These drawings are not contractually binding. For the installation design, refer to the specific dimensional drawing available on request.

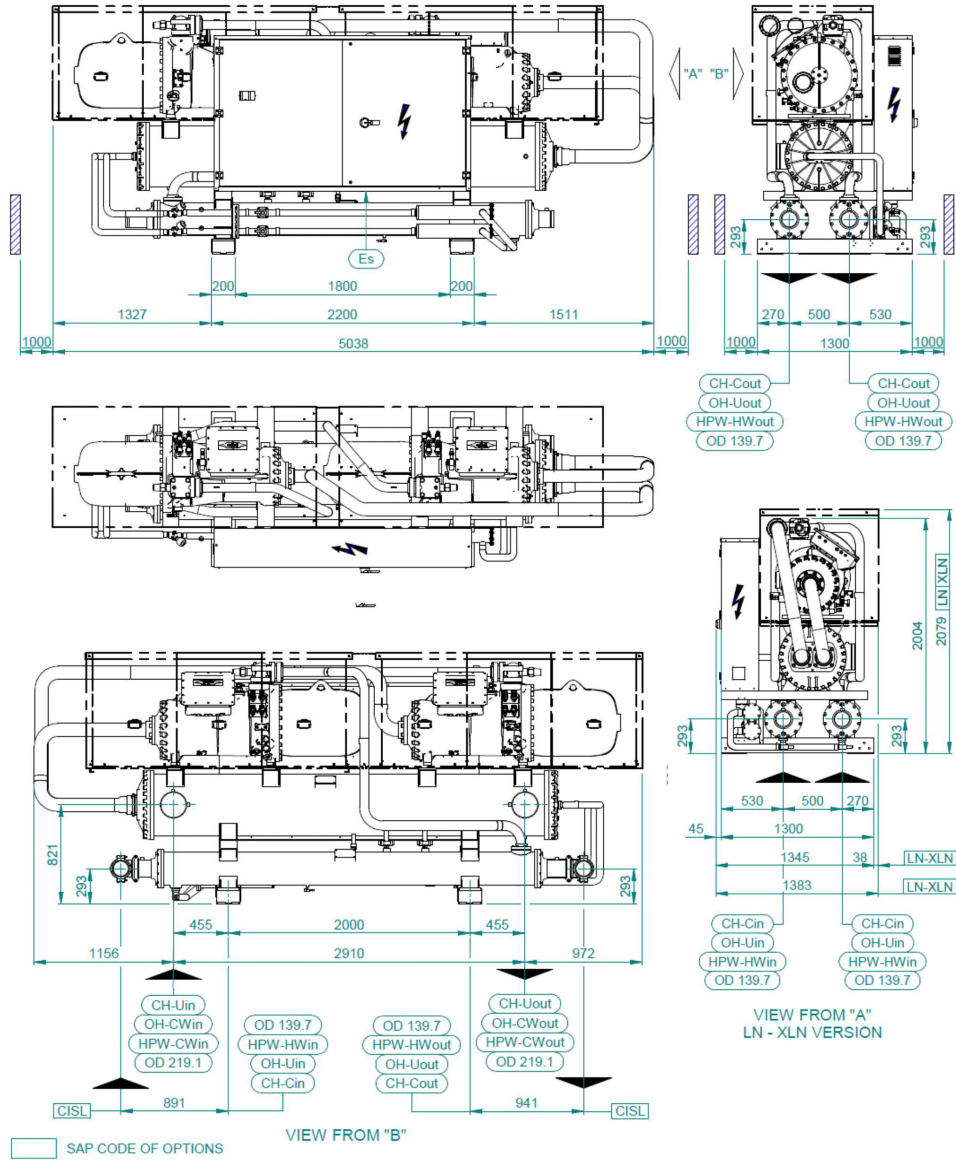

Note: These drawings are not contractually binding. For the installation design, refer to the specific dimensional drawing available on request.

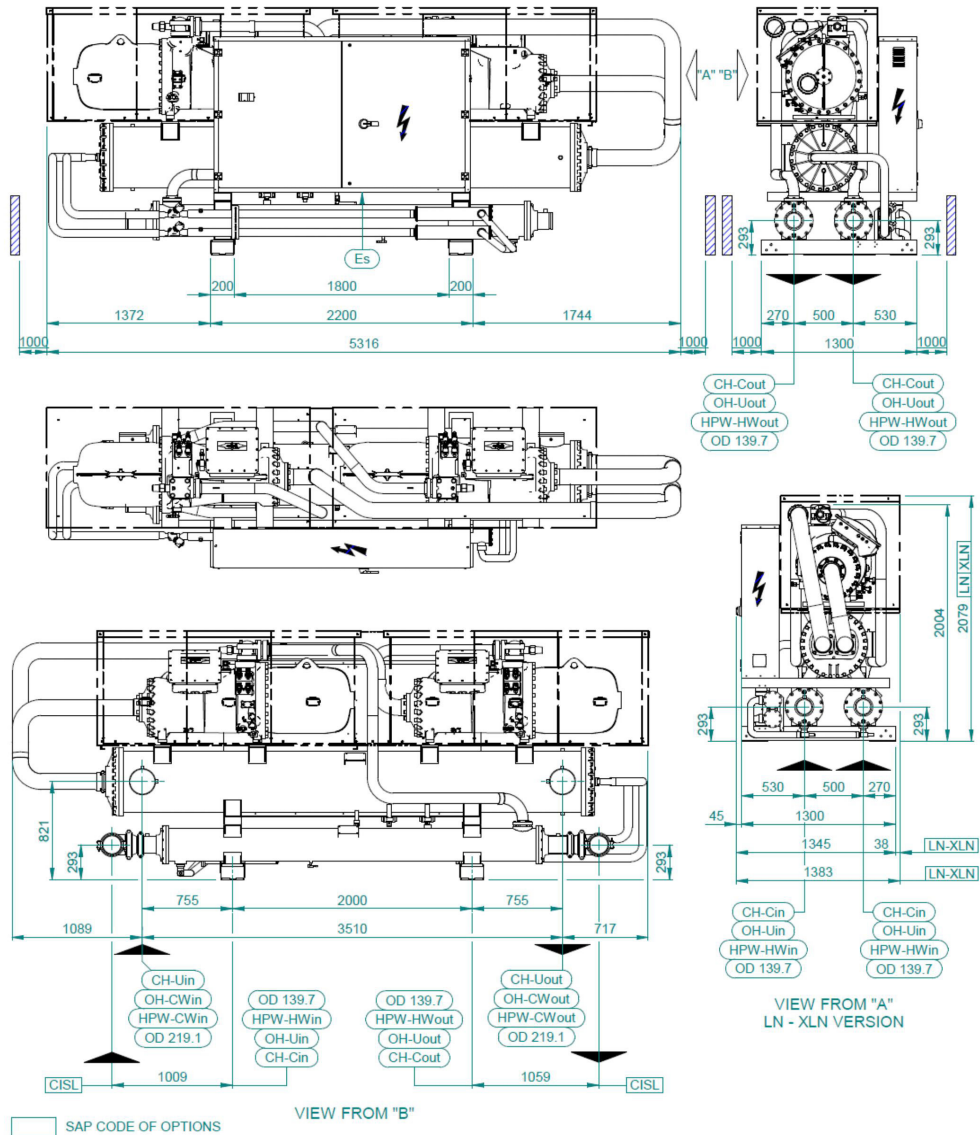

Note: These drawings are not contractually binding. For the installation design, refer to the specific dimensional drawing available on request.

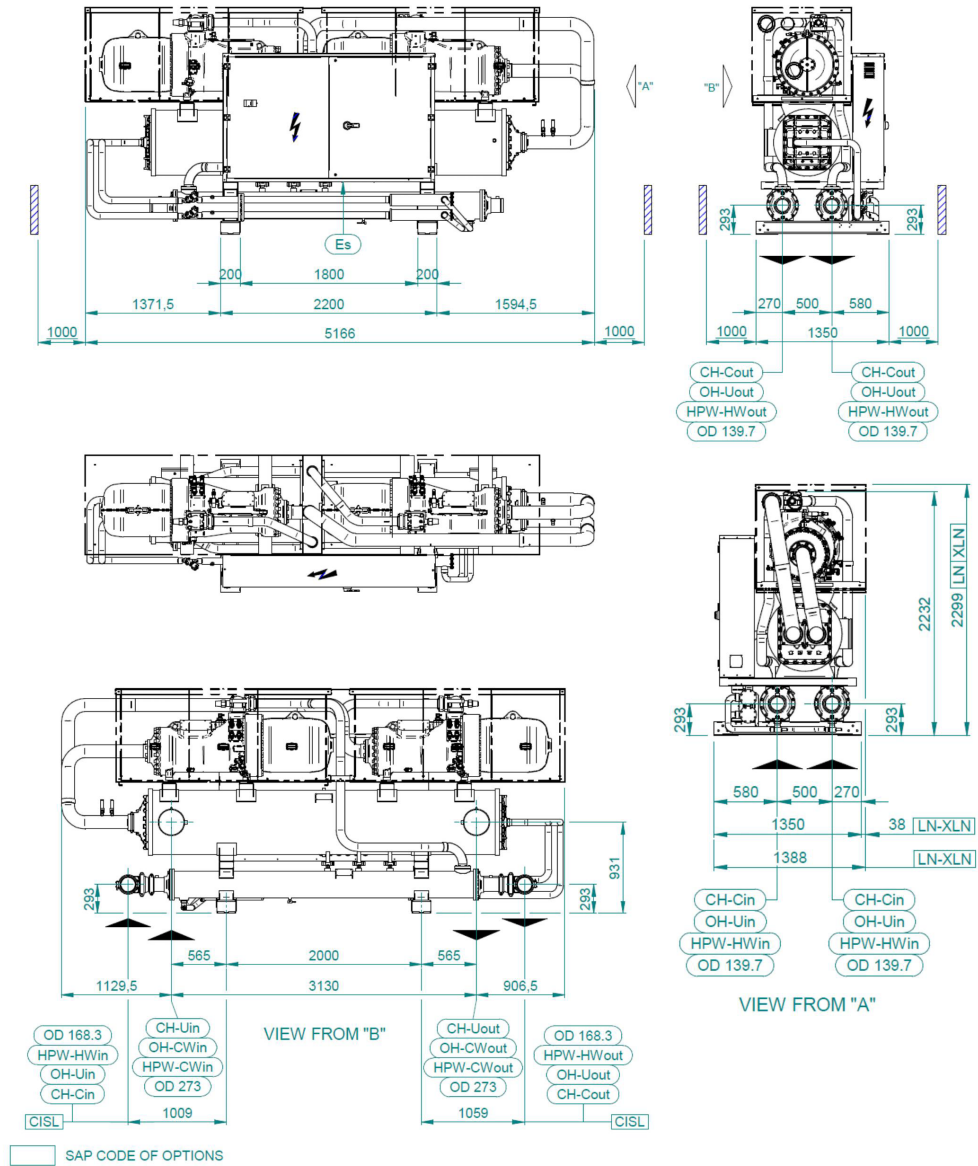

Note: These drawings are not contractually binding. For the installation design, refer to the specific dimensional drawing available on request.

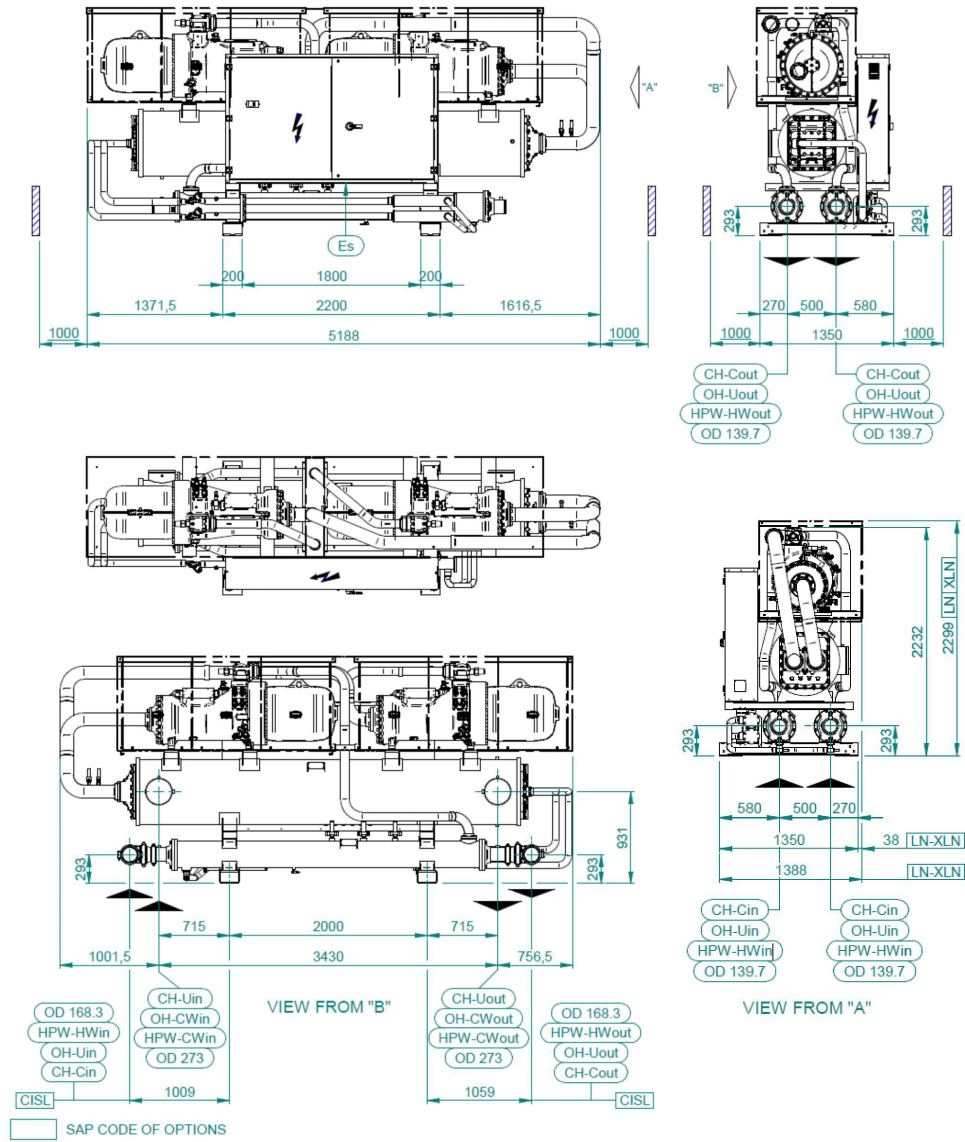

Note: These drawings are not contractually binding. For the installation design, refer to the specific dimensional drawing available on request.

MODEL	WEIGHT	WEIGHT IN FUNCTION
	kg	kg
43.1 CH-OH-HPW	2.623	2.879
43.1 CH-OH-HPW_LN-XLN	2.859	3.115
50.1 CH-OH-HPW	2.66	2.952
50.1 CH-OH-HPW_LN-XLN	2.895	3.187
58.1 CH-OH-HPW	2.872	3.255
58.1 CH-OH-HPW_LN-XLN	3.107	3.490
66.1 CH-OH-HPW	2.913	3.298
66.1 CH-OH-HPW_LN-XLN	3.147	3.532
70.1 CH-OH-HPW	3.020	3.379
70.1 CH-OH-HPW_LN-XLN	3.255	3.614
79.1 CH-OH-HPW	3.072	3.457
79.1 CH-OH-HPW_LN-XLN	3.308	3.693
63.2 CH-OH-HPW	3.654	4.058
63.2 CH-OH-HPW_LN-XLN	4.101	4.505
72.2 CH-OH-HPW	3.739	4.137
72.2 CH-OH-HPW_LN-XLN	4.187	4.585
88.2 CH-OH-HPW	4.852	5.330
88.2 CH-OH-HPW_LN-XLN	5.360	5.838
101.2 CH-OH-HPW	5.064	5.684
101.2 CH-OH-HPW_LN-XLN	5.572	6.192
116.2 CH-OH-HPW	5.215	5.816
116.2 CH-OH-HPW_LN-XLN	5.723	6.324
132.2 CH-OH-HPW	5.458	6.148
132.2 CH-OH-HPW_LN-XLN	5.968	6.658
143.2 CH-OH-HPW	5.873	6.962
143.2 CH-OH-HPW_LN-XLN	6.381	7.470
159.2 CH-OH-HPW	5.987	7.156
159.2 CH-OH-HPW_LN-XLN	6.495	7.664

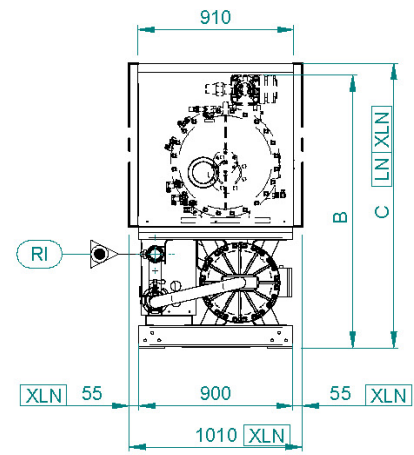
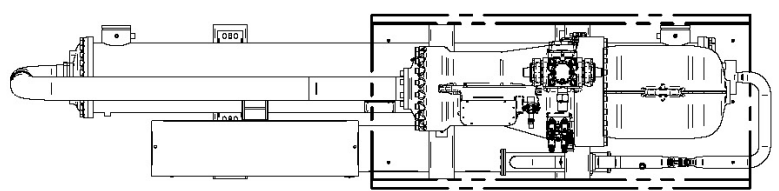
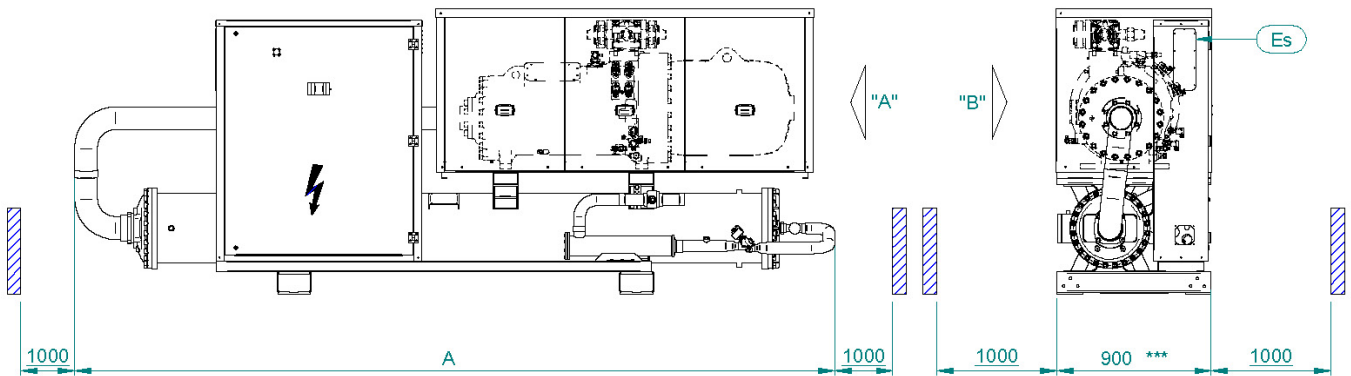

VIEW FROM "A"

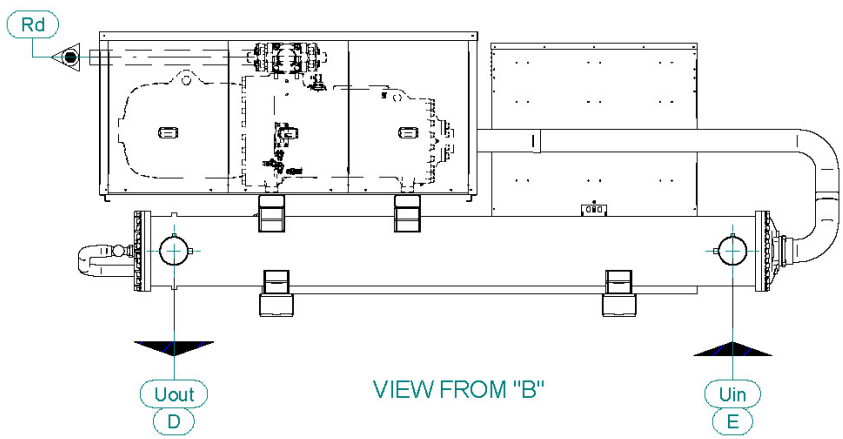

VIEW FROM "B"

	Connections					
SIZE	43.1	50.1	58.1	66.1	70.1	79.1
Rd	76	76	76	89	89	89
Ri	54	54	54	67	67	67

size	Dimensions			Connections	
	A	B	C	D	E
43.1	4090	1600	1600	OD 139.7	OD 139.7
50.1	4680	1600	1600	OD 139.7	OD 139.7
58.1	4120	1600	1665	OD 168.3	OD 168.3
66.1	4180	1600	1665	OD 168.3	OD 168.3
70.1	4180	1600	1665	OD 168.3	OD 168.3
79.1	4460	1600	1665	OD 168.3	OD 168.3

N.B: This drawing is referred to standard version; the overall dimensions and the weight could slightly change in case of DC.

*** This dimension does not consider the main switch handle.

Note: These drawings are not contractually binding, to be considered preliminary. For the installation design, refer to the specific dimensional drawing available on request.

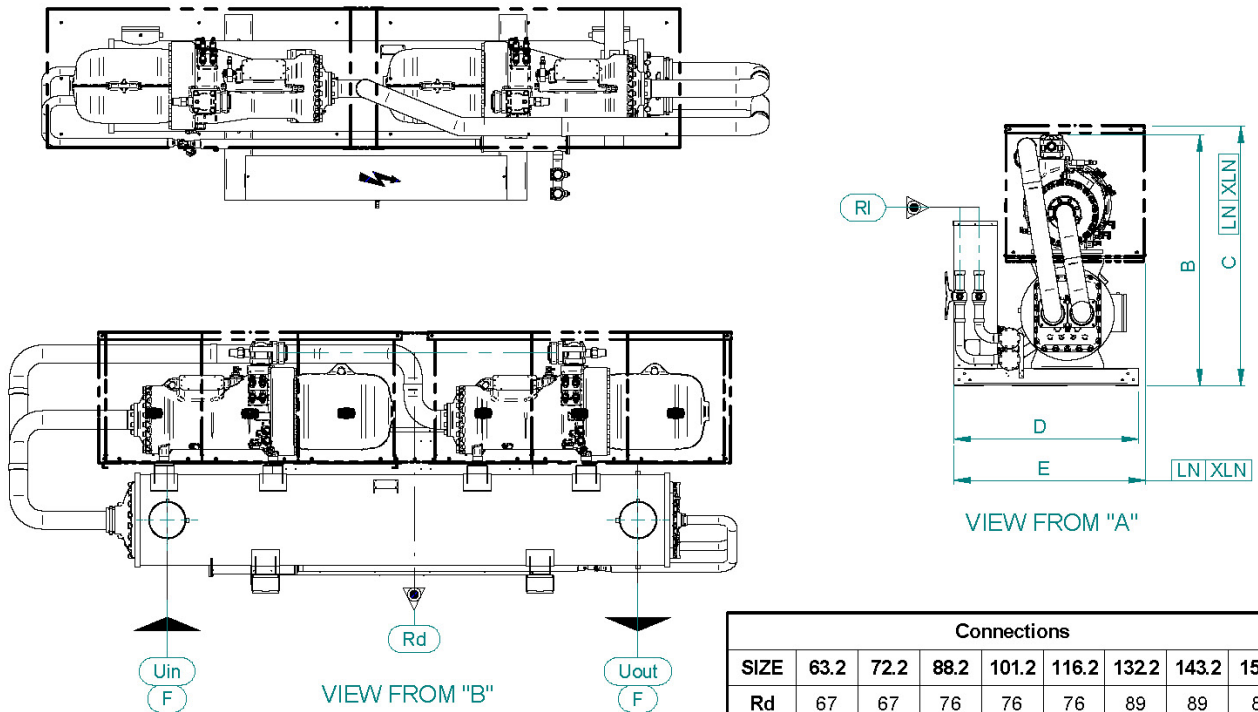
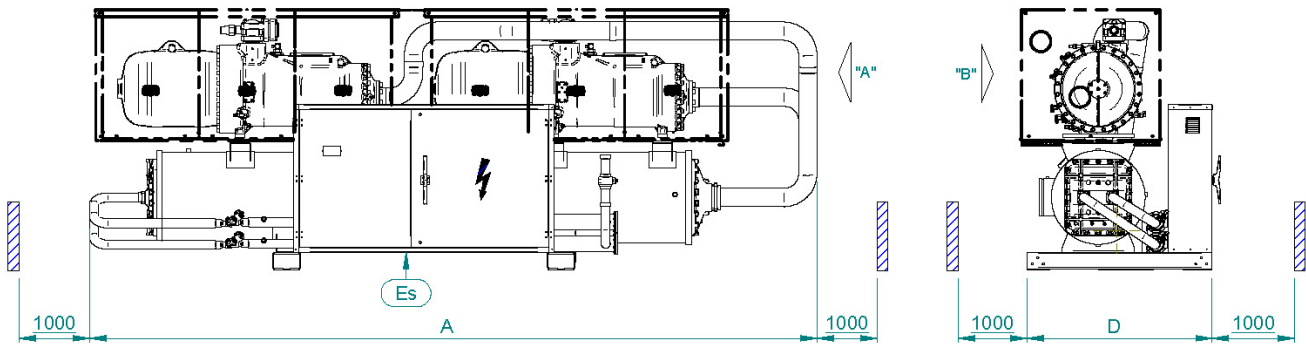

	Connections							
SIZE	63.2	72.2	88.2	101.2	116.2	132.2	143.2	159.2
Rd	67	67	76	76	76	89	89	89
Rl	42	42	54	54	54	67	67	67

size	Dimensions					Connections
	A	B	C	D	E	F
63.2	4600	1500	1610	1300	1360	OD 168.3
72.2	4600	1500	1610	1300	1360	OD 168.3
88.2	5280	1530	1610	1300	1360	OD 168.3
101.2	4980	1610	1715	1300	1360	OD 219.1
116.2	4980	1610	1715	1300	1360	OD 219.1
132.2	5250	1610	1715	1300	1360	OD 219.1
143.2	5380	1840	1900	1350	1415	OD 273
159.2	5380	1840	1900	1350	1415	OD 273

N.B: This drawing is referred to standard version; the overall dimensions and the weight could slightly change in case of DC.

Dimensions "D" and "E" does not consider the main switch handle.

Note: These drawings are not contractually binding, to be considered preliminary. For the installation design, refer to the specific dimensional drawing available on request.

MODEL	WEIGHT	WEIGHT IN FUNCTION
	kg	kg
43.1 LC	2062	2245
43.1 LC_LN-XLN	2327	2510
50.1 LC	2097	2314
50.1 LC_LN-XLN	2362	2579
58.1 LC	2312	2619
58.1 LC_LN-XLN	2582	2889
66.1 LC	2358	2665
66.1 LC_LN-XLN	2622	2929
70.1 LC	2462	2742
70.1 LC_LN-XLN	2727	3007
79.1 LC	2512	2818
79.1 LC_LN-XLN	2777	3083
63.2 LC	2863	3161
63.2 LC_LN-XLN	3331	3629
72.2 LC	2904	3184
72.2 LC_LN-XLN	3372	3652
88.2 LC	3834	4166
88.2 LC_LN-XLN	4353	4685
101.2 LC	4020	4490
101.2 LC_LN-XLN	4538	5008
116.2 LC	4168	4619
116.2 LC_LN-XLN	4685	5136
132.2 LC	4392	4926
132.2 LC_LN-XLN	4910	5444
143.2 LC	4806	5737
143.2 LC_LN-XLN	5324	6255
159.2 LC	4918	5929
159.2 LC_LN-XLN	5437	6448

Note: This table is not to be considered binding, preliminary data. For the installation design, refer to the specific dimensional drawing available on request.

INSTALLATION ADVICE

The units described in this document are, by nature, strongly affected by the characteristics of the system, the working conditions and the installation site.

Remember that the unit must be installed by a qualified and skilled technician, and in compliance with the national legislation in force in the destination country.

The installation must be done in such a way that it will be possible to carry out all routine and non-routine maintenance operations.

Before starting any work, you must carefully read the "Installation, operation and maintenance manual" of the machine and do the necessary safety checks to prevent any malfunctioning or hazards.

We give some advice below that will allow you to increase the efficiency and reliability of the unit and therefore of the system into which it is inserted.

Water characteristics

To preserve the life of the exchangers, the water is required to comply with some quality parameters and it is therefore necessary to make sure its values fall within the ranges indicated in the following table:

Total hardness	2,0 ÷ 6,0 °f
Langelier index	- 0,4 ÷ 0,4
pH	7,5 ÷ 8,5
Electrical conductivity	10 ÷ 500 µS/cm
Organic elements	-
Hydrogen carbonate (HCO₃⁻)	70 ÷ 300 ppm
Sulphates (SO₄²⁻)	< 50 ppm
Hydrogen carbonate / Sulphates (HCO₃⁻/SO₄²⁻)	> 1
Chlorides (Cl⁻)	< 50 ppm
Nitrates (NO₃⁻)	< 50 ppm
Hydrogen sulphide (H₂S)	< 0,05 ppm
Ammonia (NH₃)	< 0,05 ppm
Sulphites (SO₃), free chlorine (Cl₂)	< 1 ppm
Carbon dioxide (CO₂)	< 5 ppm
Metal cations	< 0,2 ppm
Manganese ions (Mn⁺⁺)	< 0,2 ppm
Iron ions (Fe²⁺ , Fe³⁺)	< 0,2 ppm
Iron + Manganese	< 0,4 ppm
Phosphates (PO₄³⁻)	< 2 ppm
Oxygen	< 0,1 ppm

Installation of water filters on all the hydraulic circuits is obligatory.

The supply of the most suitable filters for the unit can be requested as accessory. In this case, the filters are supplied loose and must be installed by the customer following the instructions given in the installation, operation and maintenance manual.

Glycol mixtures

With temperatures below 5°C, it is mandatory to work with water and anti-freeze mixtures, and also change the safety devices (anti-freeze, etc.), which must be carried out by qualified authorised personnel or by the manufacturer.

Liquid outlet temperature or minimum ambient temperature	°C	0	-5	-10	-15	-20	-25	-30	-35	-40
Freezing point	°C	-5	-10	-15	-20	-25	-30	-35	-40	-45
Ethylene glycol	%	6	22	30	36	41	46	50	53	56
Propylene glycol	%	15	25	33	39	44	48	51	54	57

The quantity of antifreeze should be considered as % on weight

Minimum water content in the system

For correct operation of the unit, it is necessary to ensure a buffering on the system such as to comply with the minimum operating time considering the greater between the minimum OFF time and the minimum ON time. In short, these contribute to limiting the number of times the compressors are switched on per hour and to preventing undesired deviations from the set point of the delivered water temperature.

Larger amounts of water are in any case always preferable, because they allow a smaller number of starts and switch-offs of the compressors, less wear of them and an increase in the efficiency of the system as a consequence of a reduction in the number of transients.

$$V_{min} = \frac{P_{tot} \cdot 1.000}{N} \cdot \frac{300}{\Delta T \cdot \rho \cdot c_p} + P_{tot} \cdot 0,8$$

where

V_{min} is the minimum water content of the system [l]

P_{tot} is the total cooling capacity of the machine [kW]

N: number of capacity reduction steps

ΔT : differential allowed on the water temperature. Unless otherwise specified, this value is considered to be 2.5K

ρ : density of the heat-carrying fluid. Unless otherwise specified, the density of water is considered

c_p : specific heat of the heat-carrying fluid. Unless otherwise specified, the specific heat of water is considered

Considering the use of water and grouping together some terms, the formula can be re-written as follows:

$$V_{min} = \frac{P_{tot}}{N} \cdot 28,66 + P_{tot} \cdot 0,8$$

For the N values, consider the following convention:

- for units with 1 compressor N = 4
- for units with 2 compressors N = 8

Installation site

To determine the best installation site for the unit and its orientation, you should pay attention to the following points:

- compliance with the clearance spaces indicated in the official dimensional drawing of the unit must be guaranteed so as to ensure accessibility for routine and non-routine maintenance operations
- you should consider the origin of the hydraulic pipes and their diameters because these affect the radiuses of curvature and therefore the spaces needed for installing them
- you should consider the position of the cable inlet on the electrical control panel of the unit as regards the origin of the power supply
- if the installation includes several units side by side, you should consider the position and dimensions of the manifolds of the heat exchangers

Once the best position for the unit has been identified, you must check that the support slab has the following characteristics:

- its dimensions must be proportionate to those of the unit: if possible, longer and wider than the unit by at least 30 cm and 15/20cm higher than the surrounding surface
- it must be able to bear at least 4 times the operating weight of the unit
- must allow the unit to be installed in a level position

The units are designed and built to reduce to a minimum the level of vibration transmitted to the ground, but it is in any case advisable to use rubber or spring anti-vibration mounts, which are available as accessory and should be requested when ordering.

The anti-vibration mounts must be fixed to the machine before positioning the unit on the ground.

Swegon Operations s.r.l.

Via Valletta, 5 - 30010

Cantarana di Cona, (VE) Italy - T. +39 0426 921111 - F. +39 0426 302222

www.blueboxcooling.com - info@bluebox.it



Swegon Operations s.r.l. a socio unico - P.IVA 02481290282

Company directed and coordinated by Investment Latour (Sweden)