

# BLBd

Installation – Commissioning – Maintenance

20211213

## Maintenance

The mixing box is equipped with an inspection cover made of plexiglas. The motor is coupled to the mixing box damper blade via connecting rods and a spindle that extends into the mixing box through a brass bush. The inspection cover can be dismantled, as required. It is advisable to switch off the ventilation before you dismantle the inspection cover.

Check the linkage system between the motor and the damper blade. Make sure that all the parts are in place and that screws have not come loose.

The spindle and the brass bush should be checked at regular intervals. Make sure that the spindle runs easily through the brass bush. Whenever the need arises the spindle should be cleaned with appropriate degreasing agent; then it should be oiled with a thin oil film and wiped dry of any excess oil.

The respective service function staff must determine the time interval for inspection. This depends on how clean the supply air is and how the ambient environment looks.

We recommend inspection at least once a year.

We recommend lubricating the spindle with a foodstuff-classified penetrating maintenance oil, such as Omega 638 food grade 4.

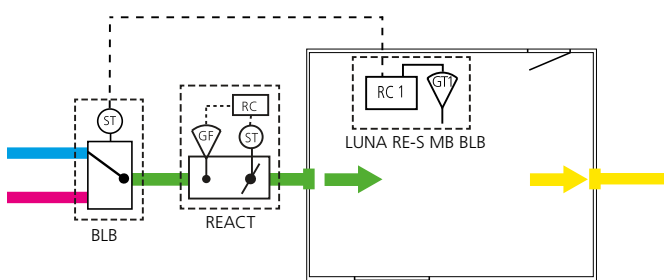

Figure 1. Description of the function of the BLB for an electric control system in combination with the REACT and LUNA RE-S MB BLB.

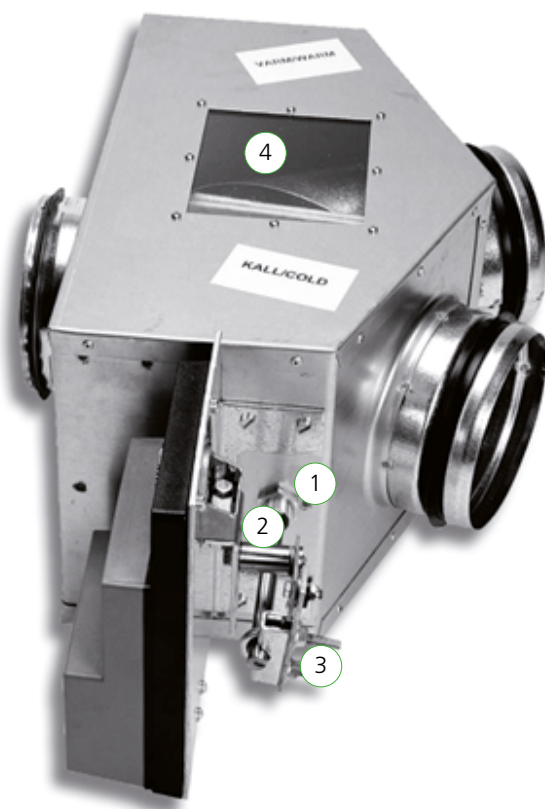
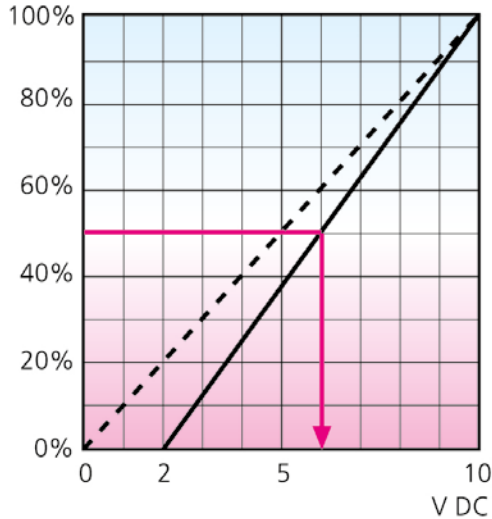

Figure 2.  
1. Brass bush  
2. Spindle  
3. Connecting rods  
4. Plexiglas

### Electric actuator control signals

The diagram below shows the mixing damper blade position in relation to the control signal, electric. 100% denotes full cooling. 0% denotes full heating. For the best control, the room regulator should be set for mixing box control, i.e. have its neutral position at 5V. On the LUNA RE-S MB BLB, this function can be selected using the LUNAd T-CU hand-held terminal. See the commissioning instructions for the LUNA RE-S MB.



### Dimensions and weights

Size	Dimensions (mm)							
	A	B	C1	ød	D	E	F	V
100	210	260	129	99	198	79	60	30
125	210	310	129	124	232	94	60	30
160	210	385	129	159	284	115	60	30
200	250	450	129	199	338	136	60	30
250	300	550	129	249	406	161	60	30
315	365	660	271	314	498	194	60	30
400	450	830	271	399	612	239	60	30

Size	Weight (kg)
	BLB-0 / BLB-1
100	4,9
125	5,5
160	7,0
200	8,4
250	11,3
315	18,0
400	25,0

### Wiring diagram for electric damper actuator

Connect the control signal from the room regulator to input Y (wire marked 3). Output U is a true value signal. Design power consumption: 5 VA, applies to BLB motor and LUNA RE-S MB BLB.

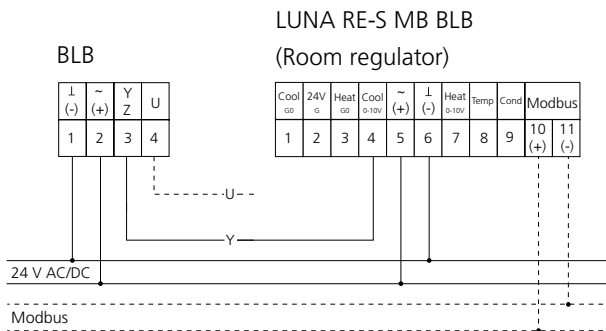

Figure 3. Wiring diagram, BLB with electric motor.

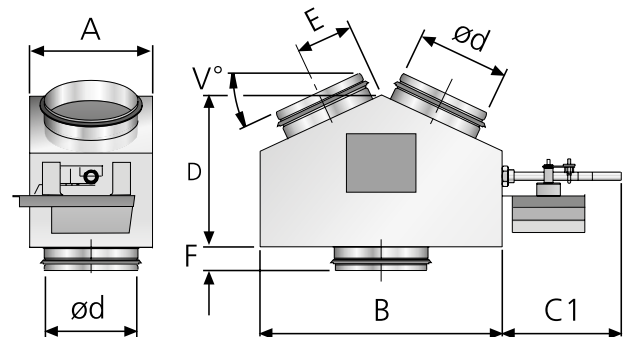

Figure 4. Dimensions, BLB.