

Beta Rev RFE

40÷240 kW



General

Customizable, high efficiency air / water chiller and heat pump with hermetic scroll compressors for indoor applications.

Configurations

RFE: Configuration with EC radial fans.

(Chiller and heat pump)

RFE HE: High efficiency configuration with EC radial fans

(Chiller only)

RFE SLN: Super low noise configuration with EC radial fans

(Chiller and heat pump)

DS: Unit with desuperheaters

DC: Unit with recovery condenser

Strengths

- ▶ Configuration with EC radial fans Maximum useful head 200-250Pa
- ▶ 3 types of pumps, standard, oversized and for high percentages of glycol (up to 50%) (options)
- ▶ Integrated hydraulic module with tank (options)
- ▶ BlueThink advanced control with integrated web server. Multilogic function and Blueeye® supervision system. (options)
- ▶ Flowzer: inverter driven pumps (options)

BlueBox 
by Swegon

Beta Rev RFE

Description of accessories	8
Refrigerant circuit accessories	8
Fan accessories	10
Hydraulic circuit accessories	11
Electrical accessories	15
Network accessories	18
Other accessories	22
Technical specifications	24
Ecodesign	34
Electrical specifications	41
Hydraulic modules	44
Pump data	47
User-side exchanger flow rate fields	48
Operating limits	49
Beta Rev RFE	49
Beta Rev RFE HE - RFE SLN	51
Beta Rev RFE SLN	52
Noise levels	53
Noise levels	54
Installation advice	58
Water characteristics	58
Glycol mixtures	58
Minimum water content in the system	59
Installation site	60
Installations that require the use of treated coils	61



Beta Rev RFE

Water chiller unit with hermetic scroll compressors, air disposal with centrifugal fans and high-user plate heat exchanger.

STRUCTURE

The unit structure is made of galvanized and painted sheet, with polyester powder RAL 7035 at 180 ° C, which give it a high resistance to atmospheric agents.

The structure has a load-bearing frame, with removable panels covered with a sound-absorbing mat in polyurethane foam.

All screws and bolts are stainless steel.

REFRIGERANT

The unit is charged with refrigerant R410A, with GWP=2088 (value at 100 years).

COMPRESSORS

The compressors are hermetic orbiting spiral scroll compressors connected in tandem. They are provided with thermal overload protection by internal Klixon® or external Kriwan© module (depending on the model) and with oil equalization line. All the compressors are fitted as standard with crankcase heater.

The compressors are enclosed in a dedicated technical compartment, which can be accessed by removing the panneling to allow maintenance operations to be carried out even with units running.

SOURCE-SIDE HEAT EXCHANGER

(for chiller unit)

The exchangers are made with microchannel aluminium coils.

Thanks to continuous research in the alloys field, and sophisticated production methods, microchannel coils are made using specific aluminium alloys for the tubes and for the fins. This allows the effects of galvanic corrosion to be drastically reduced to always ensure protection of the tubes that confine the refrigerant. Tubes and fins are also subjected to SiFLUX coating processes (or equivalent) or have zinc added to further increase their corrosion resistance.

The use of microchannel coils, as opposed to conventional copper/aluminium coils, reduces the total weight of the unit and reduces the refrigerant charge.

Options are available for installation in environments with a particularly aggressive atmosphere or in coastal or highly industrialized areas. See section: "Description of accessories".

(for HP units)

The exchangers are made with finned pack coils with copper tubes and aluminium fins.

At the base of each coil, there is an Anti-Ice Circuit: this helps to prevent ice formation in the lower part of the coil and therefore allows the unit to operate even with extremely harsh temperatures and with high humidity levels.

The Anti-Ice Circuit is shut off by a solenoid valve managed by the controller of the unit to ensure this is running only when the coils work as evaporator and only when the external air temperature makes it really necessary.

Options are available for installation in environments with a particularly aggressive atmosphere or in coastal or highly industrialized areas. See section: "Description of accessories".

FANS

The fans are radial with backward curved blades with directly coupled motor.

The fan includes the shroud, designed to optimize its efficiency and reduce noise emission to a minimum, and the safety guard.

All units have vertical exhaust as standard and, for the basic unit, the available maximum pressure is 200-250Pa.

USER-SIDE HEAT EXCHANGER

The exchanger is a braze-welded stainless steel plate heat exchanger, insulated with a shroud of closed-cell insulating material.

For dual circuit models, the unit uses two heat exchangers already manifolded inside the unit and therefore with a single hydraulic connection.

The exchanger is also equipped with thermostat-controlled anti-freeze heater to protect it from ice formation when the unit is not running.

REFRIGERANT CIRCUIT

Each refrigerant circuit of the basic unit (cooling only) comprises:

- valve on the liquid line
- charging valves
- liquid sight glass
- replaceable solid cartridge dehydrator filter (except for sizes 3.2, 4.2 and 5.2 where the filter is a weld-on filter)
- thermostatic expansion valve with pressure equalization
- high and low pressure switches

The pipes of the circuit and the exchanger are insulated with extruded closed-cell expanded elastomer.

As an accessory, all the units can be fitted with an electronic expansion valve that allows machine stability to be reached more quickly and better superheating control than the mechanical expansion valve, to maximize the use of the evaporator in all load conditions.

ELECTRICAL CONTROL PANEL

The electrical control panel is made in a painted galvanized sheet-iron box with forced ventilation and IP54 protection rating.

The electrical control panel of the basic unit comprises:

- main disconnect switch
- automatic circuit breakers for compressors with fixed calibration
- fuses for protecting the fans and auxiliary circuits
- thermal magnetic circuit breakers for the pumps (if present)
- contactors for compressors, fans and pumps (if present)
- thermal magnetic circuit breakers for pumps (if present)
- phase monitor
- potential-free general alarm contacts
- single potential free operating contacts for compressors, fans and pumps (when present)
- microprocessor controller with display accessible from the outside
- external air temperature probe
- microprocessor controller with display accessible from the outside

All the electrical cables inside the panel are numbered and the terminal board dedicated to the customer's connections is coloured orange so that it can be quickly identified in the panel.

The unit power supply is 400V / 3 ~ / 50Hz for all models.

CONTROL BLUETHINK

The unit is supplied as standard with parametric control. The advanced control can be requested as accessory.

Main controller functions parametric

The control allows the following functions:

- water temperature adjustment, with control of the water entering the user-side heat exchanger
- freeze protection
- compressor timings
- automatic rotation of compressor starting sequence
- recording of the alarm log
- RS485 serial port with Modbus protocol
- digital input for general ON/OFF
- digital input for Summer/Winter selection (only for HP units)

For further details on available functions and on displayed information, refer to the specific documentation of the controller.

By default, the serial connections present as standard are enabled only for reading from BMS. Enabling of writing from BMS is to be requested when ordering.

Main controller functions advanced

The control allows the following functions:

- water temperature adjustment, with control of the water entering the user-side heat exchanger
- freeze protection
- compressor timings
- automatic rotation of compressor starting sequence
- recording of the log of all machine inputs, outputs and states
- automatic rotation of compressor starting sequence
- recording of the alarm log
- RS485 serial port with Modbus protocol
- Ethernet serial port with Modbus protocol and integrated web server preloaded web page
- digital input for general ON/OFF
- digital input for Summer/Winter selection (only for HP units)

For further details on available functions and on displayed information, refer to the specific documentation of the controller.

By default, the serial connections present as standard are enabled only for reading from BMS. Enabling of writing from BMS is to be requested when ordering.

Main functions of the webserver (only for units with advanced control)

As standard, the Bluethink controller integrates a web-server with a preloaded web page that is accessed via password.

The web page allows the following functions to be carried out (some of these are available only for users with advanced level rights):

- display of the main functions of the unit such as unit serial n°, size, refrigerant
- display of the general status of the machine: water inlet and outlet temperatures, external air temperature, mode (chiller or heat pump), evaporating and condensing pressures, suction and discharge temperatures
- display of the status of compressors, pumps, expansion valves
- display in real time of the graphs of the main quantities
- display of the graphs of logged quantities
- display of alarm log
- management of users on several levels
- remote ON/OFF
- remote set point change
- remote time band change
- remote summer winter mode selection (only for HP units)

Human-Machine Interface

The control has a graphic display that allows the following information to be displayed:

- water inlet and outlet temperature
- set temperature and differential set points
- description of alarms
- hour meter of operation and number of start-ups of the unit, the compressors and the pumps (if present)
- high and low pressure values, and relevant condensing and evaporating temperatures
- external air temperature
- superheating at compressor suction.

Management of defrost cycles

(only for HP units)

For defrost management, the control of the unit uses a sliding intervention threshold, depending on the pressures inside the unit and the external air temperature. By putting together all this information, the control can identify the presence of ice on the coil and activates the defrosting sequence only when necessary, so as to maximize the energy efficiency of the unit.

Sliding management of the defrost threshold ensures that, as the absolute humidity of outdoor air decreases, the frequency of the defrost cycles gradually decreases because they are carried out only when the ice formed on the coil actually penalizes performance.

In addition, the Anti-Ice Circuit helps to prevent ice formation in the lower part of the coil and so allows the unit to operate even with extremely harsh temperatures and with high humidity levels.

The combination of defrost cycle management with sliding intervention threshold, defrost system and Anti-Ice Circuit allows the number and duration of defrost cycles to be optimized and reduced to a minimum.

CONTROLS AND SAFETY DEVICES

All the units are fitted with the following control and safety components:

- user-side water temperature probe
- antifreeze probe on the user side heat exchanger
- high pressure switch with manual reset
- low pressure safety device with automatic reset, for a limited number of occurrences, managed by the controller
- compressor overtemperature protection
- fan overtemperature protection
- differential flow switch

TESTING

All units are factory-tested and supplied complete with oil and refrigerant, except for the LE and LE/HP versions that are charged with nitrogen.

VERSIONS

RFE: unit with EC radial fans

Units with this option are made using radial fans with backward curved blades, without scroll. The directly coupled electric motor is of the EC (Electronically Commutated) type. This type of fan, in addition to a greater efficiency given by the lack of sliding parts and sliding of the magnetic fields, allows to self-adapt to the pressure drops of the aerodynamic ducting, even when these should change over time due to dirtying of filters and channels. The correct speed of the fans is identified according to the condensing control that is standard for units with this option. With this type of fan, the use of belts and pulleys that need greater maintenance is avoided. For some sizes, this option requires the addition of an exhaust plenum placed above the machine. Plenum and fans are fixed with screws and can therefore be disassembled on site to make it easier to pass through doorways. Refer to the dimensional specifications for more details.

RFE HE: unit with high efficiency EC radial fans

The high efficiency units use larger coils than the basic unit, in order to increase the ratio between exchange surfaces and capacity of the compressors.

RFE SLN: unit with super silenced EC radial fans

The units in the RFE SLN version provide for the use of the soundproofed compressor compartment, larger batteries compared to the standard efficiency unit and fans with speed regulator and reduced air flow. The speed reduction of the fans is such that, under nominal operating conditions, the air flow rate and noise level are lower than those of the basic version of the unit.

In any case, the use of the speed adjuster to reduce the air flow rate allows rotation of the fans at maximum speed when external air temperature conditions are particularly critical and therefore guarantees the same operating limits as the high efficiency version.

Furthermore, for the units in the RFE SLN / HP version that operate in heat pump mode, the fans always operate at 100% speed, thus ensuring the same performance levels as the high-efficiency versions.

OPTIONS

/HP: reversible heat pump

The /HP units comprise (for each refrigerant circuit):

- 4-way reversing valve
- fluid accumulator
- second electronic expansion valve.
- Anti-Ice Circuit at the base of each coil

The Anti-Ice Circuit helps to prevent ice formation in the lower part of the coil and therefore allows the unit to operate even with extremely harsh temperatures and with high humidity levels.

For defrost management, the control of the unit uses a sliding intervention threshold, depending on the pressures inside the unit and the external air temperature. By putting together all this information, the control can identify the presence of ice on the coil and activates the defrosting sequence only when necessary, so as to maximize the energy efficiency of the unit.

Sliding management of the defrost threshold ensures that, as the absolute humidity of outdoor air decreases, the frequency of the defrost cycles gradually decreases because they are carried out only when the ice formed on the coil actually penalizes performance.

The combination of defrost cycle management with sliding intervention threshold, defrost system and Anti-Ice Circuit allows the number and duration of defrost cycles to be optimized and reduced to a minimum.

Summer/winter switching can be done from the control keypad, digital input or BMS (requires write enabling).

/DC: unit with total recovery condenser

In addition to the set-up of a chiller only unit, /DC units comprise:

- a heat recovery condenser for recovering 100% of the condensation heat on each refrigerant circuit. The exchanger is a brazed plate heat exchanger; for dual circuit units, the heat exchangers are to be manifolded outside the unit (by the customer)
- temperature probe at the inlet of the heat recovery heat exchanger; for dual circuit units, the probe is supplied with the unit and is to be positioned on the heat exchanger inlet manifold (by the customer)
- liquid receiver for each refrigerant circuit with system for emptying the refrigerant from the condensing coil
- potential free contact in the electrical control panel for activation of recovery.

When required by the system, through the closing of a contact, the control automatically manages activation of recovery. Recovery management is carried out through a control on the temperature of the return water. The control also automatically manages safety deactivation of recovery if the condensing pressure becomes too high, and changes to using the condensing coils.

This option is not available for /HP units

/DS: unit with desuperheater

/DS units comprise (for each refrigerant circuit) an exchanger for condensation heat recovery of up to 20% (depending on size, version and operating conditions), placed in series with the condensing coil. The exchanger is a braze-welded plate heat exchanger. For multi-circuit units, the exchangers are to be manifolded outside the unit (by the customer).

The desuperheater can be used during operation in cooling mode. However, it can also be used in heating mode on condition that the following measures are taken:

- a valve (either 2- or 3-way) must be installed on the desuperheater water circuit;
- the valve must be monitored using a temperature control system;
- the valve must be operated to regulate the temperature of the input water into the desuperheater = IWTds.

First, enter the unit heating setpoint, which corresponds to the temperature of water delivered to the heating unit = LWTu_Heating. Then set the condition below:

- $IWTds > LWTu_Heating + 10 [K]$

The valve, the control systems and their installation, setup operations, etc. are the responsibility of the client. If heat recovery is not required during operation in heat pump mode, or where the above requirements are not met, the water circuit of the desuperheater must be shut off. Desuperheater operation in heat pump mode reduces the heating capacity transferred from the unit to the user's hydronic circuit. When a desuperheater is fitted the max. temperature of water delivered to the heating unit (LWTu_Heating) is reduced.

An illustrative graph is shown below in which, as the ambient temperature changes, (T_{air}) and as the temperature of the water leaving the heat recovery heat exchanger changes, ($T_{w,out DS}$), the percentage of recovered heat is shown as an indication (Recovery ratio).

Condensation heat recovery is a function of size, version and operating conditions.

The percentage of recovered heat is calculated as the ratio between recovered heat flow to the desuperheater and the heat flow to the condenser under nominal conditions, therefore evaporator inlet-outlet water temperature 12-7°C.

In the following graph, a constant temperature delta of 5°C between water inlet and outlet at the heat recovery heat exchanger has been considered.

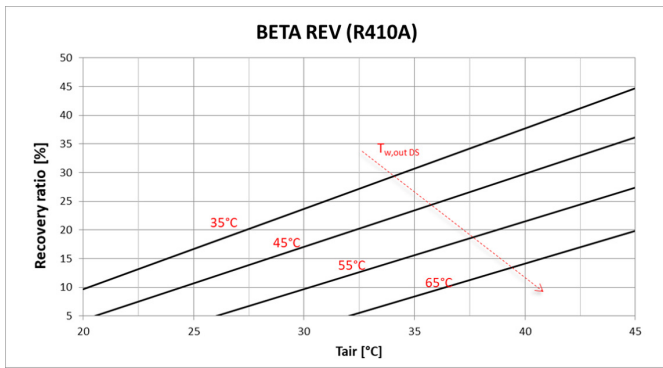

To maximize the use of the accessory and optimize machine operation, combination with the speed adjuster of the fans or with the EC fans is recommended.

/LN: silenced unit

In the unit with /LN option, all the compressors are enclosed in a compartment that is fully soundproofed with sound absorbing material and soundproofing material.

HYDRAULIC MODULES

All units can be fitted with hydraulic module in various configurations:

- /1P: hydraulic module with one pump
- /2P: hydraulic module with two pumps
- /1PS: hydraulic module with one pump and buffer tank
- /2PS: hydraulic module with two pumps and buffer tank

All the above-mentioned modules have pumps with standard discharge head.

The following are also available:

- modules /1PM, /2PM, /1PMS and /2PMS that have pumps with increased available discharge head
- modules /1PG, /2PG, /1PGS and /2PGS that have pumps suitable for operating with glycol up to 50%

Hydraulic modules with one pump have:

- one pump
- an expansion vessel

Hydraulic modules with two pumps have:

- two pumps
- a check valve on the delivery side of each pump
- an expansion vessel

In the version with 2 pumps, these are always with one on standby while the other is working. Switching over between the pumps is automatic and is done by time (to balance the hours of operation of each one) or in the event of failure.

Hydraulic modules with tank also have:

- a gate valve at the inlet of the pump or the suction manifold
- a tank with drain valve and air valve

Refer to the table of configurations that are not possible to check for availability of specific set-ups.

Hydraulic modules with tank also have:

- a gate valve at the inlet of the pump or the suction manifold
- a tank with drain valve and air valve

Refer to the table of configurations that are not possible to check for availability of specific set-ups.

All the hydraulic circuit components are fully insulated, except for:

- drain valves
- venting valves
- tank plugs
- safety valves
- expansion vessel
- probe pockets

DESCRIPTION OF ACCESSORIES

Some accessories may be incompatible with each other even if not expressly indicated.

Refrigerant circuit accessories

MAFR Pressure gauges

The operating pressures of each circuit of the unit can be displayed on the control by accessing the relevant screens. Also, the machine can be fitted with pressure gauges (two for each circuit) installed in a clearly visible position. These allow reading in real time of the working pressures of the refrigerant gas on the low pressure side and on the high pressure side of each refrigerant circuit.

RIC Liquid receiver

The adoption of this accessory always guarantees correct feeding of the expansion valve even when the unit is subjected to wide external air temperature ranges.

This accessory is standard on DC and HP units.

RUB Compressor suction and delivery valves

The valves situated on the delivery side and on the suction side of the compressors allow the compressor to be isolated from the rest of the refrigerant circuit, so making the maintenance operations quicker and less invasive

DVS Double safety valve

With this accessory, instead of each individual safety valve per circuit, there is a "candelabrum" with two safety valves and a diverter valve for choosing the valve in operation. This allows the safety valves to be replaced without having to drain the machine and without having to stop it.

BT Backup battery for electronic expansion valve

When the compressors stop, the controller always closes the electronic expansion valve to prevent dangerous refrigerant migration. The presence of the backup battery ensures that the electronic valve is kept in closed position even when there is no power supply

This option uses a condenser as energy storage, and not an ordinary coil. In this way, it is not affected by the memory effect of normal coils and the need for maintenance is avoided.

BC Capacitive backup battery for electronic expansion valve

When the compressors stop, the controller always closes the electronic expansion valve to prevent dangerous refrigerant migration. The presence of the backup battery ensures that the electronic valve is kept in closed position even when there is no power supply

This option uses a condenser as energy storage, and not an ordinary coil. In this way, it is not affected by the memory effect of normal coils and the need for maintenance is avoided.

VS Liquid line solenoid valve

This accessory prevents refrigerant migration that could damage the compressor on starting.

VTE Electronic expansion valve

The use of this component is particularly advisable on units operating in very variable heat load or operating mode conditions, as in the case of joint management of air conditioning and high temperature water production. The use of an electronic thermostatic valve allows you to:

- maximize heat exchange at the evaporator
- minimize response times to changes in load and operating conditions
- optimize control of overheating
- ensure maximum energy efficiency

BK Brine Kit

This accessory is compulsory if a water temperature set point lower than or equal to +3°C is used (if the unit is provided with double set point or variable set point, the lower set point is considered).

The accessory consists of increased insulation and suitable sizing and calibration of some components.

The inlet and outlet temperatures of the user-side exchanger must be given on ordering to allow correct setting of the alarm parameters and verification of the sizing of the expansion valve.

The cooling set point can then be changed by the customer in an interval that, compared to the set point given on ordering, ranges from -1K up to the allowed limit temperature.

The unit will be optimized to work at the set point temperature given on ordering. For different set points, the cooling capacity provided and the level of efficiency of the machine could decrease and move away from these conditions.

RPR Refrigerant leak detector

With this accessory, a refrigerant leak detector is placed inside each compressor compartment. Detection of a refrigerant leak is managed by the controller through a specific alarm and display of a specific icon on the display of the controller. This alarm stops the unit.

RPP Refrigerant leak detector with automatic pump down

With this accessory, a refrigerant leak detector is placed inside each compressor compartment. Detection of a refrigerant leak is managed by the control through a specific alarm and display of a specific icon on the display of the control. For all the circuits of the unit, the alarm also starts the machine stopping procedure with pump down, confining all the refrigerant in the coils.

The accessory includes the capacitive backup battery.

The accessory can be applied only to units in LN or SLN set-up.

Fan accessories

FLA Flange on suction

The accessory has the function of allowing the ducting of the unit suction. Installation is the responsibility of the installer.

Accessory supplied loose.

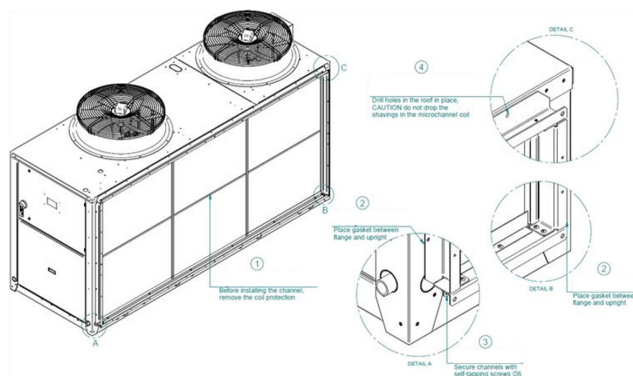

Hydraulic circuit accessories

IVPO Soundproofed pump compartment

With this accessory, the motor and the impeller of the pumps are enclosed in a compartment that is fully soundproofed with sound absorbing material and soundproofing material.

RA Antifreeze heater

These are electric heaters inserted on the user-side heat exchanger, on the pumps and in the tank (depending on the configuration of the machine) to prevent damage to the hydraulic components due to ice formation during periods when the machine is stopped.

Based on normal operating conditions and the percentage of glycol in the system, an appropriate "antifreeze alarm" temperature is set in the control. When a temperature that is 1K higher than the antifreeze alarm threshold is detected at the outlet from the exchanger, the pump (if present) and the antifreeze heaters are switched on. If the temperature of the outgoing water reaches the antifreeze alarm threshold, the compressors are stopped, keeping the heaters and the pumps active, and the general alarm contact of the machine is activated.

VSIW Water-side safety valve

With this accessory, a safety valve is inserted in the hydraulic circuit of the unit: when the calibration pressure is reached, the valve opens and, by discharging (to be routed by the customer), prevents the system pressure from reaching limits that are dangerous for the components present in the system. The valves have positive action, that is, performance is guaranteed even if the diaphragm deteriorates or breaks.

FLUS Flow switch (instead of the water differential pressure switch)

As an alternative to the differential pressure switch (standard flow sensor), it is possible to request the paddle flow switch as accessory. This detects when there is no water flow to the user-side exchanger and sends a signal to the control of the unit that will stop the compressors to prevent damage to the exchangers.

Application of this accessory is compulsory for units that use non-glycol water and work with a yearly cycle where external air temperatures are zero or below.

The flow switch is supplied loose (installation by the customer) and replaces the water differential pressure switch (standard).

PFP User-side pump with Pulse function

As standard, the unit is set to keep the system-side circulation pump on all the time, even when the set point temperature is reached.

But when the unit is provided with this accessory, on reaching the set point, the controller will switch off the pump and start it again at regular intervals for a sufficient time to measure the water temperature. If the controller verifies that the water temperature is still in set point condition, it will switch off the pump again. Otherwise the controller will start the compressors again to meet the requirements of the system.

This accessory therefore allows electrical absorption due to pumping to be drastically reduced, especially in spring and autumn when the load is extremely low.

FVDE FLOWZER VDE - flow rate control to keep the flow rate constant as the external working conditions of the system change;

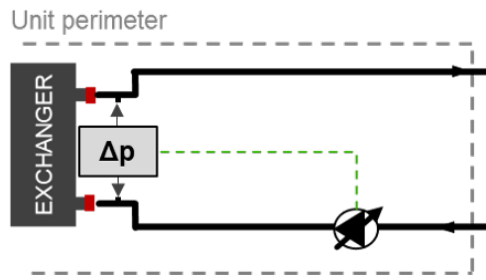

Flowzer VDE requires a differential pressure transducer to be installed in the machine. Through this transducer, the inverter can gauge the actual pressure at the ends of the heat exchanger installed in the machine and it can automatically adapt the pump speed for a constant flow value under all conditions. Flowzer VDE must be combined with Flowzer VP.

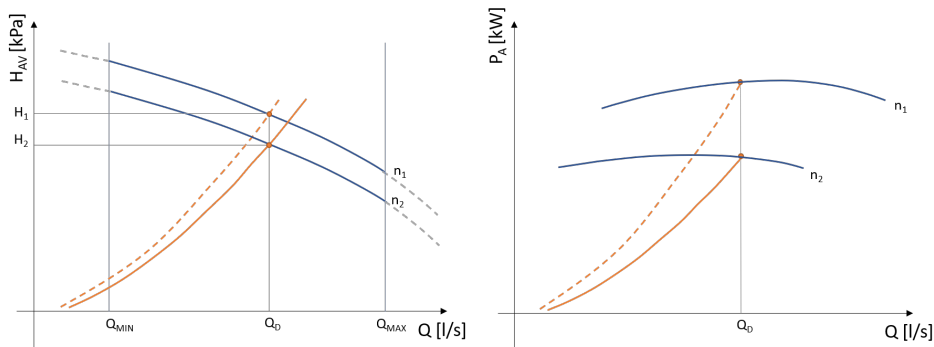

Flowzer VDE is used to automatically adjust the pump speed. As the graph shows, the inverter trips and increases the pump speed if a different condition occurs which would cause an undesired drop in the flow rate (e.g. operation of an external dry cooler). This is a more accurate solution than the VP option alone as it always provides for the water flow (Q_d) required by the design conditions.

FVP FLOWZER VP - Inverter for manual pump adjustment

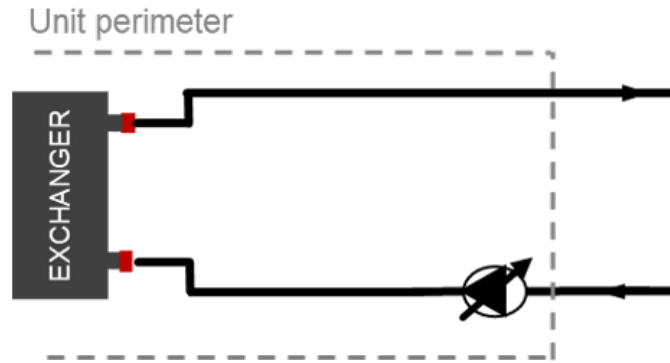

The accessory consists of inserting an inverter in the machine to manually adjust the speed of the pump (or pumps) in order to calibrate the pump flow rate on the head losses of the system.

This accessory is to be combined with one of the integrated hydraulic modules that can be selected for the unit. Units equipped with integrated hydraulic module allow a certain level of available discharge head (point A) to be obtained under nominal flow rate conditions Q_d .

But the actual head loss level of the system (e.g. characteristic curve R') normally causes the pump to find a different equilibrium point (point B), with a flow rate Q_r higher than Q_d .

In this condition, in addition to having a different flow from the nominal one (therefore also a different temperature jump), there is also a greater absorption of electric power from the pump itself.

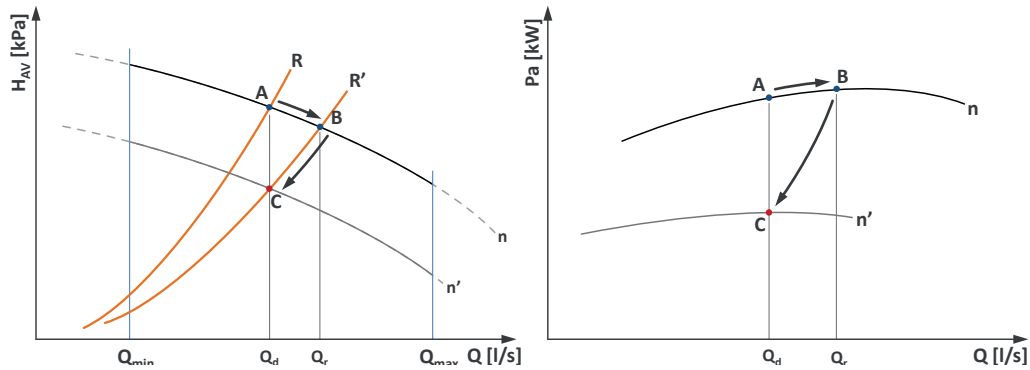

The use of the Flowzer allows the pump speed to be set manually (e.g. at speed n' instead of n) to obtain the design water flow rate and thermal gradient (point C). Once the adjustment procedure has been carried out, the pump will always work at a fixed flow rate.

The adoption of the VP Flowzer allows to considerably reduce the electrical power consumption of the pump with a consequent energy saving. By way of example, a reduction in the flow rate of 10% leads to a reduction in power consumption of around 27%.

For the freecooling units the Flowzer VP is able to manage two different speeds of the pump automatically compensating the pressure drops of the water coil.

FVD FLOWZER VD - control of available pump discharge head for variable flow systems without monitoring the flow rate limits;

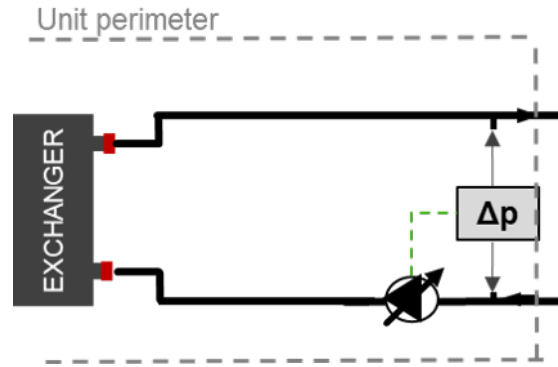

Flowzer VD requires two pressure transducers to be installed in the machine. Through these transducers, the inverter can gauge the actual pressure at the ends of the system and it can automatically adapt the pump speed to obtain a set available discharge head value. Flowzer VD must be combined with Flowzer VP. This accessory therefore allows a constant pressure system to be achieved.

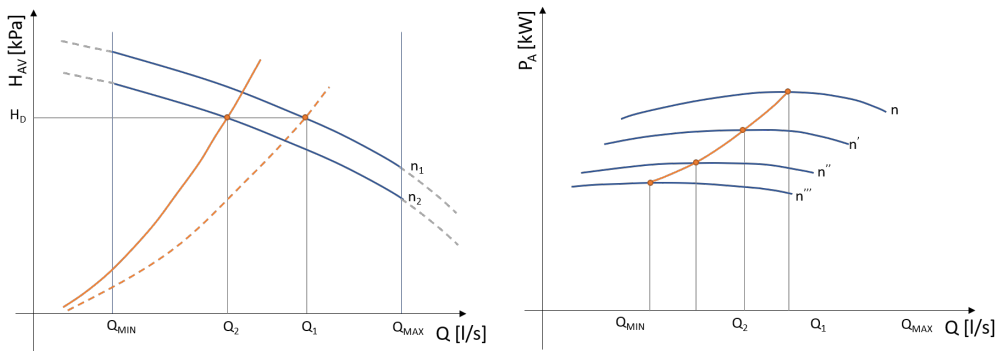

With the Flowzer VD, the customer can set, directly on the display, the available discharge head value (H_d) that the unit must maintain. As can be seen from the graph as the user request decreases, the resistant curve of the plant moves to the left, consequently the inverter reduces the speed of the pump in order to maintain the useful head necessary for the unit. With this system a significant reduction in electrical power is achieved. The customer will have to check that, in minimum flow rate conditions (that is, with the maximum number of user points closed), this is always higher than or equal to the minimum flow rate allowed by the unit. This accessory is useful when the total head losses of the circuit are slightly variable or when they change depending on the seasons (for example, some user points are active only during summer operation and not during winter operation). The use of this accessory also allows the pump speed to be adapted to possible fouling of the filter on the hydraulic circuit.

Electrical accessories

A41 Power supply 415/3/50

Power supply 415/3/50. Available for the following units: for Zeta Rev and Zeta Rev LE from size 12.2 up to size 24.4, for HE and SLN configurations from size 8.2 up to size 16.4

A43 Power supply 400/3/50

Power supply present as standard in the following units: for Zeta Rev and Zeta Rev LE from size 12.2 to size 24.4, for HE and SLN configurations from size 8.2 to size 16.4

CA Advanced control

With this accessory, the advanced control is used also for sizes/versions provided with the parametric control as standard.

LIID Limitation of the current absorbed by digital input

When this accessory is requested, a digital input is prepared in the terminal board to activate the forced capacity reduction of the unit to a set fixed level.

This accessory is useful when there is a need to necessarily limit the power absorbed by the unit as regards particular conditions.

We point out that, in some conditions (for example, during defrosting, oil return cycles or hourly compressor rotation procedures), the controller could force the unit to operate at full capacity for limited periods of time.

RIF Power factor correction to $\cos\varphi \geq 0.95$

With this accessory, an electrical control panel (IP54 protection rating), containing power factor correction capacitors to make the $\cos\varphi$ of the unit greater than or equal to 0.95, is supplied with the unit. The capacitors should be connected (by the customer) to the electrical control panel of the unit in the specially prepared terminal board.

Besides reducing the absorbed reactive power, the use of this accessory also allows the maximum absorbed current to be lowered.

SOFT Electronic soft-starter

The scroll compressors have DOL (Direct On Line) starting and their torque (T) and current (I) characteristics are shown in the following diagrams:

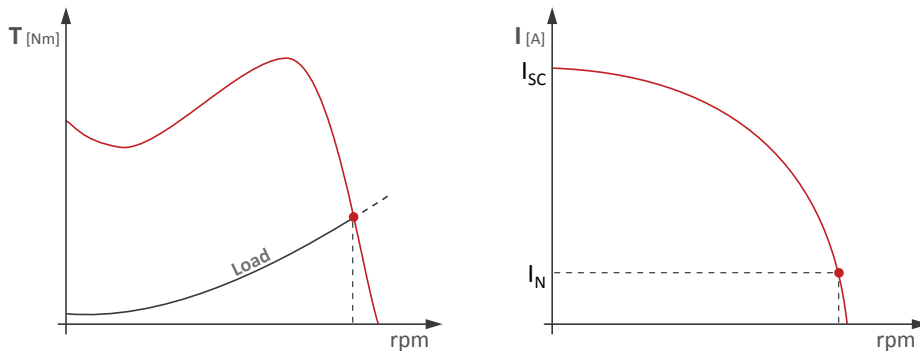

For an individual compressor, the normal starting current I_{SC} will be 4-5 times its rated current I_N .

If the unit is equipped with the electronic soft-starter accessory, the starting of each compressor is done with an acceleration ramp that allows the effective value (rms value) of the inrush current of the individual compressor to be lowered.

CSP Set point compensation depending on external air temperature

For units fitted with this accessory, the set point of the unit is set so that it can vary between two values, a maximum and a minimum, depending on the external air temperature. The compensation ramp and the maximum and minimum values of the set point can be changed by the user.

Unless otherwise specified in the order, the controller will be set to implement a positive compensation logic according to the temperatures shown in the following diagrams:

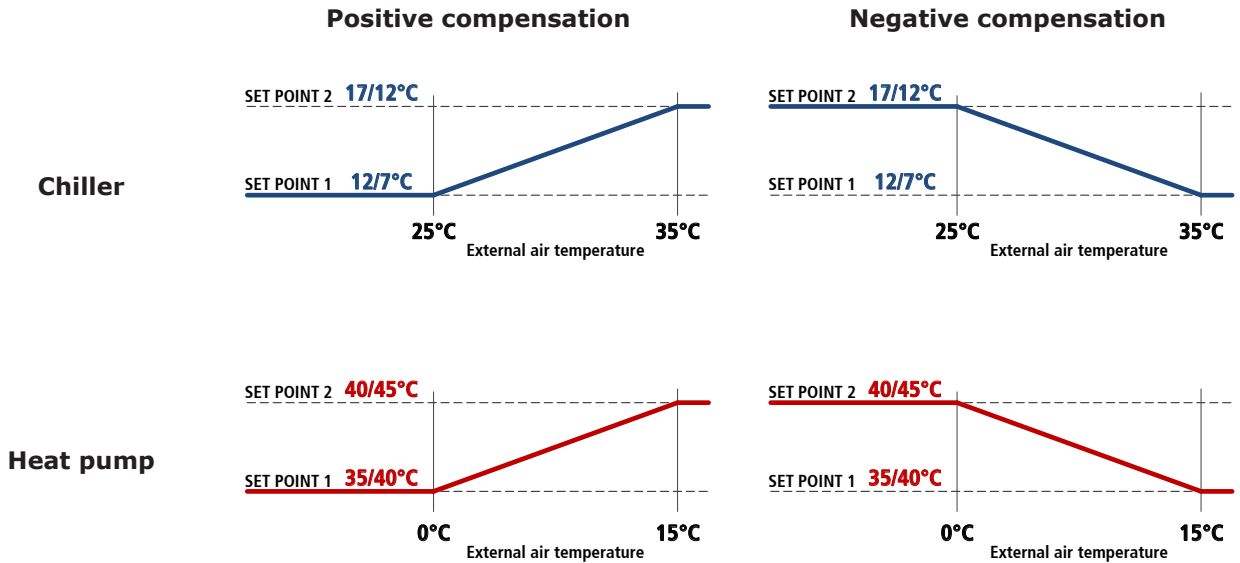

COTW Outgoing water temperature control

With this accessory, outgoing instead of incoming water temperature control is used.

SETD Double set point from digital input

The accessory allows you to preset two different operating set points and manage the change from one to the other through a digital signal.

The set point temperatures must be specified when ordering. For optimization of the unit, reference will be made to the lower set point in chiller mode and the higher set point in heat pump mode.

Unless otherwise specified in the order, the controller will be set at the factory with the following temperatures:

- in chiller mode, set point 1 to 7°C and set point 2 to 12°C
- in heat pump mode (only for HP units) set point 1 to 45°C and set point 2 to 40°C

If the difference between set point 1 and set point 2 is greater than 5K, it is compulsory to ask for the accessory "Electronic expansion valve".

SETV Variable set point with remote signal

The accessory allows the set point to be varied continuously between two preset values, a maximum and a minimum, depending on an external signal that can be of the 0-1V, 0-10V or 4-20mA type.

The set point temperatures and the type of signal to use for the adjustment must be specified when ordering. For optimization of the unit, reference will be made to the lower set point in chiller mode and the higher set point in heat pump mode.

Unless otherwise specified in the order, the controller will be set at the factory with 0-10V analogue input and with the following temperatures:

- in chiller mode, 0V will correspond to a set point of 7°C and 10V will correspond to a set point of 12°C
- in heat pump mode (only for HP units), 0V will correspond to a set point of 45°C and 10V will correspond to a set point of 40°C

If the difference between the minimum set point and the maximum set point is greater than 5K, it is compulsory to ask for the accessory "Electronic expansion valve".

-
- CP Single potential free operating contacts**
For units fitted with this accessory, there are clean contacts available on the terminal board inside the electrical box from which the customer can acquire signals that show the status of the unit's components (compressors, fans, pumps, alarms).
- TERM Remote-controlled user terminal panel**
This accessory allows the terminal normally situated on the machine to be replicated on a support situated at a distance. It is particularly suitable when the unit is placed in an area that is not easily accessible. The accessory is supplied loose and is to be installed by the customer at a maximum distance of 120m from the unit. We advise using a cable of the following type: "TECO O.R. FE 2x2xAWG24 SN/ST/PUR".
For this accessory, there is a dedicated serial port.
- RE1P Relay for management of 1 external pump**
This accessory can be requested for units without pumps and allows a pump outside the machine to be controlled.
- RE2P Relay for management of 2 external pumps**
This accessory can be requested for units without pumps and allows two pumps outside the machine to be controlled with a running/stand-by logic by implementing a rotation on the hours of operation. The two pumps are controlled by two separate relays.
- RMMT Maximum and minimum voltage relay**
This accessory constantly monitors the voltage value and the unit's power supply phase sequence. If the supply voltage does not fall within the set parameters or there is a phase reversal, an alarm is generated that stops the machine to prevent damage to its main parts
- IACV Automatic circuit breakers**
With this accessory, automatic circuit breakers are installed instead of fuses for the protection of auxiliary loads. Also, the same accessory uses automatic circuit breakers with adjustable thermal overload protection to protect the compressors.
- SQE Heater for electrical control panel**
Electric heaters are positioned inside the electrical control panel and these prevent the formation of ice or condensation inside it.
- ARU Stopping of the unit due to temperatures below the operating limit**
With this accessory, it is possible to set the unit so that the controller switches off the compressors when the unit is operating in heat pump mode and the external air temperature falls below a minimum set limit: this will prevent the unit from going into low pressure alarm, so avoiding having to manually restart the machine. When the external air temperature returns above the set threshold temperature, the unit will automatically resume operation without it being necessary to do anything.
For units equipped with integrated pump, the pump will always be kept running so as to prevent ice formation and ensure correct reading of the temperature and antifreeze safety probes at all times.
The stopping temperature must be set based on the set point temperature and in accordance with what is allowed by the operating limits of the machine.
The same function can be used to set an external air temperature below which to use an alternative heat source because it is more efficient or economically more advantageous.

Network accessories

SERI RS485 serial connection with Modbus protocol

RS485 serial connection with Modbus protocol

PBA BACnet protocol over IP (Ethernet)

The controller is set for use, in read and write mode, of the BACnet port on IP protocol.

By default, the programming gives read-only access to the control of the unit. Reading / writing access is activable on field with a service level.

GLO Modbus Lonworks Gateway

With this accessory, a RS485/Lon gateway is installed inside the electrical control panel.

By default, the programming gives read-only access to the control of the unit. Reading / writing access is activable on field with a service level.

SW4P Network switch with 4 ports

The accessory includes installation in DIN rail of a professional 4-port network switch. Requires Blueeye via Ethernet.

SW8P Network switch with 8 ports

The accessory includes installation in DIN rail of a professional 8-port network switch.

Requires Blueeye via Ethernet.

PSN SNMP protocol

The accessory consists of a gateway that allows Ethernet connection to a SNMP manager supervision system.

The use of this accessory causes the RS485 serial port to be unavailable.

BEET Blueye® via Ethernet

Blueye® is a supervision platform that enables remote monitoring of one or more units in the same system interconnected through a network with Modbus protocol.

This accessory features the Blueye device, as already installed and wired in the unit.

The critical variables to be monitored over time are identified for each connected device. These variables are sampled and saved to the cloud so that they are accessible at all times through a web portal or a mobile APP (available for Android and iOS).

The following options can be selected for connection to the internet:

- a LAN (Ethernet) connection - available in the system;
- a connection to a mobile network - at least 3G. The data SIM card is not included.

Three different types of contracts can be signed.

Blueye® Cloud Basic:

- to monitor a max. of 20 variables in total over max. 5 units/peripherals;
- to set a min. sampling frequency of 60 seconds.

Blueye® Cloud Advanced:

- to monitor a max. of 200 variables in total over max. 10 units/peripherals;
- to set a min. sampling frequency of 5 seconds.

Blueye® Connect:

- To monitor up to 10 units/peripherals.

Subscribing to any of the **Blueye® Cloud** enables:

- viewing the history of the monitored variables, in the form of both numerical values and graphs;
- downloading the history of variables in CSV format;
- the creation of automatic reports;
- setting notifications (via APP or mail) with settable thresholds for each variable;
- switching the unit ON/OFF remotely;;;
- changing the set point remotely;
- selection of SUMMER/WINTER mode remotely (for reversible units only).

The subscription to the **Blueye® Connect** service offers the advantages below:

- a safe connection (tunnelling) between the user and the remote unit through the Blueye® portal;
- full access to the remote controller;
- real time monitoring;
- software upgrading.

Blueye® via Ethernet is only available for units supplied with an advanced controller and does not include any type of service. This service must be purchased separately based on the number of units/devices to be connected and the number of variables to be monitored. In order to connect multiple units to **Blueye® device, the network switch is required (this accessory is sold separately).**

Units can also be connected to the Blueye device through the RS485 network featuring a Modbus RTU protocol (for this option, refer to BERS accessory).

For further details, refer to the specific Blueye® documentation.

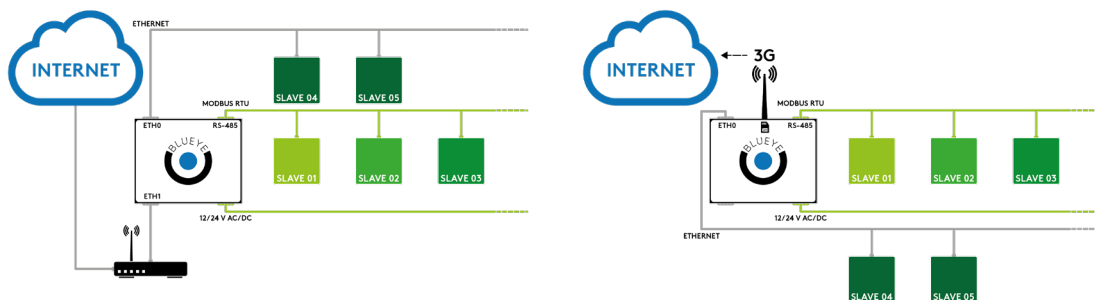

BERS Blueye® via RS485

This accessory requires use of the Blueye device, installed and wired in the unit through a RS485 serial port on the ModBus RTU protocol.

This option requires integration with one contract of the Blueye Cloud series. (Basic or Advanced one)

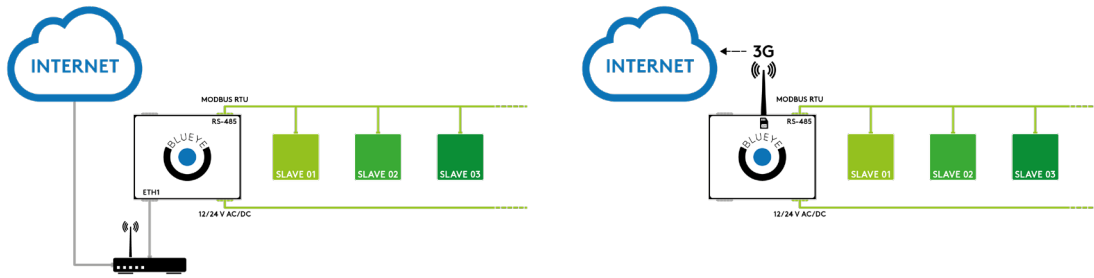

SMAR Smartlink function predisposition

This accessory makes it possible to connect the controller of the unit with the controller of a Swegon GOLD™ air handling unit via a simple serial cable, so allowing their operating logics to be merged into a single consciousness that pursues the maximum energy efficiency of the system. The RS485 serial interface is already included and dedicated to connection with Swegon units.

The option is incompatible with:

- double set point
- variable set point with remote signal
- summer/winter selection by digital input
- set point compensation depending on external air temperature
- multilogic
- all communication protocols.

SMAP Setup of Smartlink+ functions

This option is used to connect the controller in the unit with the controller of a Swegon GOLD™ air handling unit via the Ethernet port TCP/IP, so allowing the operating logics of hydronic and ventilation systems to be merged into a single logic for the achievement of maximum energy efficiency and comfort. This option is only available for units featuring an advanced controller and it is compatible with Multilogic and Hyzer systems only if the machine is the Master.

The option is incompatible with:

- double set point
- variable set point with remote signal
- set point compensation depending on external air temperature
- all communication protocols.

FMx Multilogic Function

The Multilogic function allows management of up to 32 units equipped with advanced Bluethink controller and connected in hydraulic parallel with each other.

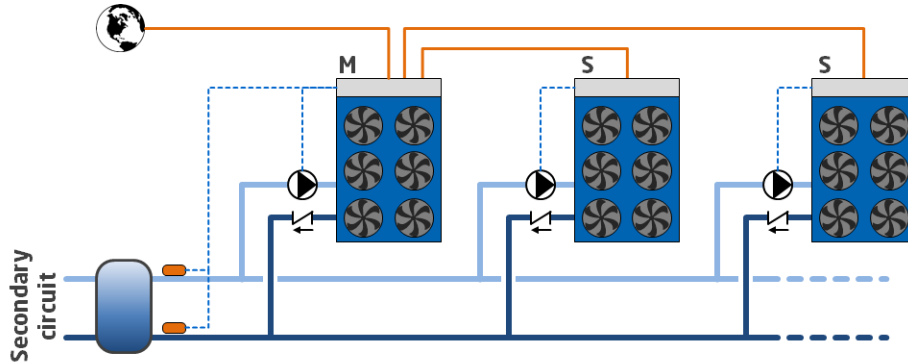

On the basis of the information recorded by the temperature probes installed on the delivery and return manifolds of the system, with the master unit, a capacity request is generated that is distributed among the units connected in the Multilogic network according to settable priority and optimization logics.

If communication between the units fails or if the master is off-line, the slave units can continue to work according to the set thermoregulation parameters.

The connected units can be different from each other, in terms of capacity and set-up, provided the following rules are complied with:

- if there are both chiller units and heat pumps in the Multilogic network, the Master unit must obligatorily be one of the HP units
- if there are both free cooling and non free-cooling units in the Multilogic network, the Master unit must obligatorily be one of the free-cooling units.

The Multilogic function that can be requested with the unit can be:

- **FM0:** Multilogic function for Slave unit
- **FM2:** Multilogic function for Master unit for managing up to 2 Slaves
- **FM6:** Multilogic function for Master unit for managing up to 6 Slaves

If you need to connect more than 6 slaves (up to 31), you can ask for a quotation from our sales department.

For the slave units, the accessory requires:

- programming of the unit as slave of a system of machines in Multilogic network

For the master units, the accessory requires:

- programming of the unit as master of a system of machines in Multilogic network
- entering of the parameters necessary for connection with the individual slave units
- installation in the electrical control panel of a network switch to allow the units to be connected in a LAN network.
- the supply of 2 temperature probes to be positioned on the delivery and return manifold of the system (supplied separately with it, installation and wiring by the customer)

The connection between the master unit and the slave units made with a CAT cable. 5E/UTP (prepared by the customer) with RJ45 connectors. Maximum cable length 100m.

For further details, please refer to the controller manual.

Other accessories

AG Rubber anti-vibration mounts

These allow you to reduce the vibrations transmitted from the unit to the surface it is standing on.
Accessory supplied loose.

MCHE E-coated microchannel coil

The e-coated microchannel coils are treated by immersion of the whole exchanger in an emulsion of organic resins, solvents, ionic stabilisers and deionised water. This is all subjected to a suitable electric field that causes the formation of a solid, uniform deposit on the exchanger. The function of this deposit will be to protect the aluminium from corrosion without penalising its thermophysical properties.

Protective treatment of the exchanger is strongly recommended if at least one of the points below is verified:

- there are obvious signs of corrosion of the exposed metal surfaces in the installation area
- the installation is located close to the sea coast
- the prevailing winds come from the sea towards the unit
- the environment is industrial with a significant concentration of pollutants
- the environment is urban with a high population density
- the environment is rural with the presence of organic discharges and effluents.

With reference to the protection criteria to follow, especially for installations close to the coast, refer to the section titled "Installations that require the use of treated coils".

RAAL Cu/Al coils

This accessory uses finned pack coils with copper tubes and aluminium fins instead of microchannel coils.

ALPR Pre-painted aluminium coil

This option uses finned pack coils with copper tubes and pre-painted aluminium fins.

ANTC Coil treated with anti-corrosion paints

The treatment is applied to the finned pack coils with copper pipes and aluminum fins and consists in the passivation of the aluminum with a polyurethane base through a procedure of immersion and then of a spray application of the coating that guarantees a double protection of the finning all over the exposure to the most aggressive environmental conditions even for more particular (or niche) process applications.

Specifically, the immersion process guarantees complete coverage of galvanic corrosion while the application of the spray protects the ends of the fins which represent the critical point for the initiation of the corrosion phenomenon.

The choice of whether or not to treat the exchanger should be made in relation to the environment in which the unit is to be installed and through observation of other structures and machinery with exposed metal surfaces present in the destination environment.

The cross observation criterion is the most valid method of selection currently available without having to carry out preliminary tests or measurements with instruments.

Protective treatment of the exchanger is strongly recommended if at least one of the points below is verified:

- there are obvious signs of corrosion on the exposed metal surfaces in the installation area
- the installation is located close to the sea coast
- the prevailing winds come from the sea and travel in the direction of the unit
- the environment is industrial with a significant concentration of pollutants
- it is an urban environment with a high population density
- it is a rural environment with the presence of organic discharges and effluents

For chiller units, this accessory also includes the "Cu/Al coil" accessory.

With reference to the protection criteria to follow, especially for installations close to the coast, refer to the section titled "Installations that require the use of treated coils".

RETE **Coil protection mesh with metal filter**
Coil protection mesh with hail-proof metal filter

VASC **Condensate drip tray**
This accessory can be combined with HP units in order to collect the condensate that forms after each coil defrost cycle. The tray is made of stainless steel and is placed under the source-side heat exchanger, at a suitable distance.

On the opposite sides of the tray, there are some 1" close nipples to allow the customer to connect a pipe to it for draining out the water so as not to cause harm or damage to people or objects.

RAV **Anti-freeze heater for condensate drip tray**
A heating cable, glued to the bottom, can be combined with the condensate drip tray to prevent ice formation at the base of the coil or near the drains.
The heater is controlled by a thermostat and is activated depending on the external air temperature.
Recommended accessory for installations in cold regions.

PREA **Unit suitable to be disassembled on site**
The unit is delivered so that it can be disassembled easily on site if this makes the installation operations easier.

A unit requested with this option is supplied:

- screwed instead of riveted
- with plugged and not welded pipes
- without refrigerant charge
- untested
- covered by the warranty only if reassembled and screwed together by personnel authorized by the factory

SLIT **Special pallet/skid for container shipment**
The unit is placed on a skid that makes the container loading and unloading operations easier.
The accessory is mandatory if shipping by container is required

FW **Water filter**
To protect the elements of the hydraulic circuit (in particular, the exchangers), there are Y filters that can stop and settle the particles that are normally present in the water flow and would otherwise settle in the more delicate parts of the hydraulic circuit and damage its heat exchange capacity.
Installation of the water filter is mandatory even when it is not supplied as an accessory.
Accessory supplied loose.

TECHNICAL SPECIFICATIONS

BETA REV RFE

			3.2	4.2	5.2	6.2	7.2	8.2	9.2	10.2
BETA REV RFE										
Cooling										
Refrigeration capacity	(1)	kW	40,5	45,4	53,08	59,8	66,82	81,1	93,01	102,1
Total absorbed power	(1)	kW	14,19	17,02	20,21	21,35	25,03	27,42	32,07	37,11
EER	(1)		2,85	2,66	2,62	2,8	2,66	2,95	2,9	2,75
Compressors										
Compressors/Circuits		n°/n°	2/1	2/1	2/1	2/1	2/1	2/1	2/1	2/1
Minimum capacity reduction step	(5)	%	50	50	50	50	50	50	43	50
Refrigerant charge CH (MCHX)	(2)	kg	3,7	5,5	5,5	6	6	9,5	10	10
Refrigerant charge CH (Cu/Al)	(2)	kg	6	7	8,8	10,5	10,5	16	17	17
Fans										
Quantity		n°	2	2	2	2	2	3	3	3
Total air flow rate CH (MCHX)		m³/h	17000	17000	15000	19000	19000	28500	28500	28500
Maximum useful head		kPa	0,25	0,25	0,25	0,25	0,25	0,25	0,25	0,25
User-side heat exchanger										
Quantity		n°	1	1	1	1	1	1	1	1
Water flow rate CH	(1)	m³/h	7	7,8	9,2	10,3	11,5	14	16	17,6
Pressure drop CH	(1)	kPa	37,5	32,5	32,5	42,2	21,7	32,8	28,3	33,7
Noise levels										
Sound power level cooling	(3)	dB(A)	89	89	89	89	89	91	91	91
Sound pressure level cooling	(4)	dB(A)	72	72	72	72	72	73	73	73
Sound power level of vers. LN cooling	(3)	dB(A)	87	87	87	87	87	89	89	89
Sound pressure level of vers. LN cooling	(4)	dB(A)	70	70	70	70	70	71	71	71
Dimensions and weights**										
Length		mm	1750	1750	1750	2200	2200	3200	3200	3200
Depth		mm	1000	1000	1000	1000	1000	1100	1100	1100
Height		mm	1780	1780	1780	2120	2120	2120	2120	2120
Operating weight		kg	606	618	621	756	780	1128	1138	1152

(1) External air temperature of 35°C and user-side heat exchanger water inlet-outlet temperature of 12-7°C. Values compliant with standard EN 14511

(2) Theoretical values referred to the basic unit. The amount of gas actually charged in the unit may differ.

(3) Unit operating at rated capacity, with no accessories of any kind - external air temperature 35°C and water input/output temperature from/to heat exchanger and user equal to 12/7°C. Values taken by measurements made in accordance with standard ISO 3744 and the Eurovent certification programme, where applicable. Binding values See NOISE LEVELS section.

(4) Values obtained from the sound power level (conditions: note 4), related to a distance of 1 m from the unit in free field with directivity factor Q=2. Non-binding values See NOISE LEVELS section.

(5) Approximate value. The minimum capacity reached by the unit depends on the operating conditions. The value shown may not be suitable for calculating the minimum volume of water: to do this, consult the "Minimum water content in the system" section.

** Basic unit without included accessories

			12.2	13.2	15.2	16.2	14.4	16.4	18.4	20.4	24.4
BETA REV RFE											
Cooling											
Refrigeration capacity	(1)	kW	116,42	125,39	146,48	159,5	136,97	153,64	189,6	208,13	233,77
Total absorbed power	(1)	kW	41,61	47,88	53,74	62,5	48,04	58,73	61,71	71,97	84,46
EER	(1)		2,79	2,61	2,72	2,55	2,85	2,61	3,07	2,89	2,76
Compressors											
Compressors/Circuits		n°/n°	2/1	2/1	2/1	2/1	4/2	4/2	4/2	4/2	4/2
Minimum capacity reduction step	(5)	%	44	50	45	50	25	25	21	25	22
Refrigerant charge CH (MCHX)	(2)	kg	11,5	11,5	15	15	16	18	19,5	19,5	21
Refrigerant charge CH (Cu/Al)	(2)	kg	18	18	26	26	29	31	35	35	40
Fans											
Quantity		n°	3	3	3	3	3	3	5	5	5
Total air flow rate CH (MCHX)		m³/h	36000	36000	40000	40000	40000	40000	57000	58950	70000
Maximum useful head		kPa	0,25	0,25	0,25	0,25	0,25	0,25	0,25	0,25	0,15
User-side heat exchanger											
Quantity		n°	1	1	1	1	2	2	1	1	1
Water flow rate CH	(1)	m³/h	20,1	21,6	25,3	27,5	23,6	26,5	32,7	35,9	40,3
Pressure drop CH	(1)	kPa	34,1	39,2	34,8	40,8	22,7	28,2	21,7	26,7	26,8
Noise levels											
Sound power level cooling	(3)	dB(A)	94	94	94	94	93	93	96	97	98
Sound pressure level cooling	(4)	dB(A)	76	76	76	76	75	75	77	78	79
Sound power level of vers. LN cooling	(3)	dB(A)	92	92	92	92	91	91	94	95	96
Sound pressure level of vers. LN cooling	(4)	dB(A)	74	74	74	74	73	73	75	76	77
Dimensions and weights**											
Length		mm	3200	3200	3200	3200	3200	3200	4200	4200	4200
Depth		mm	1100	1100	1100	1100	1100	1100	1100	1100	1100
Height		mm	2120	2120	2150	2150	2150	2150	2150	2150	2150
Operating weight		kg	1190	1230	1436	1466	1426	1576	1945	1969	2048

(1) External air temperature of 35°C and user-side heat exchanger water inlet-outlet temperature of 12-7°C. Values compliant with standard EN 14511

(2) Theoretical values referred to the basic unit. The amount of gas actually charged in the unit may differ.

(3) Unit operating at rated capacity, with no accessories of any kind - external air temperature 35°C and water input/output temperature from/to heat exchanger and user equal to 12/7°C. Values taken by measurements made in accordance with standard ISO 3744 and the Eurovent certification programme, where applicable. Binding values See NOISE LEVELS section.

(4) Values obtained from the sound power level (conditions: note 4), related to a distance of 1 m from the unit in free field with directivity factor Q=2. Non-binding values See NOISE LEVELS section.

(5) Approximate value. The minimum capacity reached by the unit depends on the operating conditions. The value shown may not be suitable for calculating the minimum volume of water: to do this, consult the "Minimum water content in the system" section.

** Basic unit without included accessories

BETA REV RFE HE

			3.2	4.2	5.2	6.2	7.2	8.2	9.2
BETA REV RFE HE									
Cooling									
Refrigeration capacity	(1)	kW	42,49	49,28	58,39	63,48	72,36	87,39	100,89
Total absorbed power	(1)	kW	13,67	16	19,31	20,36	23,56	27,45	32,1
EER	(1)		3,1	3,08	3,02	3,11	3,07	3,18	3,14
Compressors									
Compressors/Circuits		n°/n°	2/1	2/1	2/1	2/1	2/1	2/1	2/1
Minimum capacity reduction step	(5)	%	50	50	50	50	50	50	43
Refrigerant charge CH (MCHX)	(2)	kg	4,5	6,5	6,5	8	8	10	10
Refrigerant charge CH (Cu/Al)	(2)	kg	9	10	10,5	14	14	17	17
Fans									
Quantity		n°	2	2	2	3	3	3	3
Total air flow rate CH (MCHX)		m³/h	19000	19000	19000	28500	28500	36000	36000
Maximum useful head		kPa	0,25	0,25	0,25	0,25	0,25	0,25	0,25
User-side heat exchanger									
Quantity		n°	1	1	1	1	1	1	1
Water flow rate CH	(1)	m³/h	7,3	8,5	10,1	10,9	12,5	15,1	17,4
Pressure drop CH	(1)	kPa	24,9	22,6	28,2	27,1	32,8	44,4	40,9
Noise levels									
Sound power level cooling	(3)	dB(A)	89	89	89	89	89	92	92
Sound pressure level cooling	(4)	dB(A)	72	72	72	71	71	74	74
Sound power level of vers. LN cooling	(3)	dB(A)	87	87	87	87	87	90	90
Sound pressure level of vers. LN cooling	(4)	dB(A)	70	70	70	69	69	72	72
Dimensions and weights**									
Length		mm	2200	2200	2200	3200	3200	3200	3200
Depth		mm	1000	1000	1000	1100	1100	1100	1100
Height		mm	2120	2120	2120	2120	2120	2120	2120
Operating weight		kg	723	741	744	1032	1039	1043	1120

(1) External air temperature of 35°C and user-side heat exchanger water inlet-outlet temperature of 12-7°C. Values compliant with standard EN 14511

(2) Theoretical values referred to the basic unit. The amount of gas actually charged in the unit may differ.

(3) Unit operating at rated capacity, with no accessories of any kind - external air temperature 35°C and water input/output temperature from/to heat exchanger and user equal to 12/7°C. Values taken by measurements made in accordance with standard ISO 3744 and the Eurovent certification programme, where applicable. Binding values See NOISE LEVELS section.

(4) Values obtained from the sound power level (conditions: note 4), related to a distance of 1 m from the unit in free field with directivity factor Q=2. Non-binding values See NOISE LEVELS section.

(5) Approximate value. The minimum capacity reached by the unit depends on the operating conditions. The value shown may not be suitable for calculating the minimum volume of water: to do this, consult the "Minimum water content in the system" section.

** Basic unit without included accessories

			10.2	12.2	13.2	15.2	16.2	14.4	16.4
BETA REV RFE HE									
Cooling									
Refrigeration capacity	(1)	kW	111,14	127,98	139,25	159,12	179,98	144,84	171,62
Total absorbed power	(1)	kW	35,95	41,58	43,42	50,26	57,46	45,37	54,33
EER	(1)		3,09	3,07	3,2	3,16	3,13	3,19	3,15
Compressors									
Compressors/Circuits		n°/n°	2/1	2/1	2/1	2/1	2/1	4/2	4/2
Minimum capacity reduction step	(5)	%	50	44	50	45	50	25	25
Refrigerant charge CH (MCHX)	(2)	kg	12	13	16	16	16,5	19	21
Refrigerant charge CH (Cu/Al)	(2)	kg	26	26	31	31	34	35	36
Fans									
Quantity		n°	3	3	5	5	5	5	5
Total air flow rate CH (MCHX)		m³/h	40000	40000	58950	58950	58950	58950	58950
Maximum useful head		kPa	0,25	0,25	0,25	0,25	0,25	0,25	0,25
User-side heat exchanger									
Quantity		n°	1	1	1	1	1	1	1
Water flow rate CH	(1)	m³/h	19,2	22,1	24	27,4	31	25	29,6
Pressure drop CH	(1)	kPa	51,8	48,4	41,2	50	46,8	22,1	27
Noise levels									
Sound power level cooling	(3)	dB(A)	92	94	95	95	95	95	95
Sound pressure level cooling	(4)	dB(A)	74	76	76	76	76	76	76
Sound power level of vers. LN cooling	(3)	dB(A)	90	92	93	93	93	93	93
Sound pressure level of vers. LN cooling	(4)	dB(A)	72	74	74	74	74	74	74
Dimensions and weights**									
Length		mm	3200	3200	4200	4200	4200	4200	4200
Depth		mm	1100	1100	1100	1100	1100	1100	1100
Height		mm	2150	2150	2150	2150	2150	2150	2150
Operating weight		kg	1384	1410	1788	1813	1839	1749	1755

(1) External air temperature of 35°C and user-side heat exchanger water inlet-outlet temperature of 12-7°C. Values compliant with standard EN 14511

(2) Theoretical values referred to the basic unit. The amount of gas actually charged in the unit may differ.

(3) Unit operating at rated capacity, with no accessories of any kind - external air temperature 35°C and water input/output temperature from/to heat exchanger and user equal to 12/7°C. Values taken by measurements made in accordance with standard ISO 3744 and the Eurovent certification programme, where applicable. Binding values See NOISE LEVELS section.

(4) Values obtained from the sound power level (conditions: note 4), related to a distance of 1 m from the unit in free field with directivity factor Q=2. Non-binding values See NOISE LEVELS section.

(5) Approximate value. The minimum capacity reached by the unit depends on the operating conditions. The value shown may not be suitable for calculating the minimum volume of water: to do this, consult the "Minimum water content in the system" section.

** Basic unit without included accessories

BETA REV RFE SLN

			3.2	4.2	5.2	6.2	7.2	8.2	9.2
BETA REV RFE SLN									
Cooling									
Refrigeration capacity	(1)	kW	40,82	46,19	52,55	62,42	70,92	83,45	94,57
Total absorbed power	(1)	kW	13,51	16,33	19,5	19,75	23,21	27,08	32
EER	(1)		3,02	2,83	2,69	3,16	3,06	3,08	2,96
Compressors									
Compressors/Circuits		n°/n°	2/1	2/1	2/1	2/1	2/1	2/1	2/1
Minimum capacity reduction step	(5)	%	50	50	50	50	50	50	43
Refrigerant charge CH (MCHX)	(2)	kg	4,5	6,5	6,5	8	8	10	10
Refrigerant charge CH (Cu/Al)	(2)	kg	9	10	10,5	14	14	17	17
Fans									
Quantity		n°	2	2	2	3	3	3	3
Total air flow rate CH (MCHX)		m³/h	13000	13000	13000	19500	19500	32000	32000
Maximum useful head		kPa	0,25	0,25	0,25	0,25	0,25	0,25	0,25
User-side heat exchanger									
Quantity		n°	1	1	1	1	1	1	1
Water flow rate CH	(1)	m³/h	7	8	9,1	10,8	12,2	14,4	16,3
Pressure drop CH	(1)	kPa	22,4	20,1	25,4	25,3	30,5	42,9	38,8
Noise levels									
Sound power level cooling	(3)	dB(A)	85	85	85	85	85	87	87
Sound pressure level cooling	(4)	dB(A)	68	68	68	67	67	69	69
Dimensions and weights**									
Length		mm	2200	2200	2200	3200	3200	3200	3200
Depth		mm	1000	1000	1000	1100	1100	1100	1100
Height		mm	2120	2120	2120	2120	2120	2120	2120
Operating weight		kg	723	741	744	1032	1039	1043	1120

(1) External air temperature of 35°C and user-side heat exchanger water inlet-outlet temperature of 12-7°C. Values compliant with standard EN 14511

(2) Theoretical values referred to the basic unit. The amount of gas actually charged in the unit may differ.

(3) Unit operating at rated capacity, with no accessories of any kind - external air temperature 35°C and water input/output temperature from/to heat exchanger and user equal to 12/7°C. Values taken by measurements made in accordance with standard ISO 3744 and the Eurovent certification programme, where applicable. Binding values See NOISE LEVELS section.

(4) Values obtained from the sound power level (conditions: note 4), related to a distance of 1 m from the unit in free field with directivity factor Q=2. Non-binding values See NOISE LEVELS section.

(5) Approximate value. The minimum capacity reached by the unit depends on the operating conditions. The value shown may not be suitable for calculating the minimum volume of water: to do this, consult the "Minimum water content in the system" section.

** Basic unit without included accessories

			10.2	12.2	13.2	15.2	16.2	14.4	16.4
BETA REV RFE SLN									
Cooling									
Refrigeration capacity	(1)	kW	106,53	117,48	136,85	154,09	170,25	141,88	162,54
Total absorbed power	(1)	kW	35,73	41,78	43,39	50,82	58,95	45,98	55,88
EER	(1)		2,98	2,81	3,15	3,03	2,89	3,09	2,91
Compressors									
Compressors/Circuits		n°/n°	2/1	2/1	2/1	2/1	2/1	4/2	4/2
Minimum capacity reduction step	(5)	%	50	44	50	45	50	25	25
Refrigerant charge CH (MCHX)	(2)	kg	12	13	16	16	16,5	19	21
Refrigerant charge CH (Cu/Al)	(2)	kg	26	26	31	31	34	35	36
Fans									
Quantity		n°	3	3	5	5	5	5	5
Total air flow rate CH (MCHX)		m³/h	32000	32000	48000	48000	48000	48000	48000
Maximum useful head		kPa	0,25	0,25	0,25	0,25	0,25	0,25	0,25
User-side heat exchanger									
Quantity		n°	1	1	1	1	1	1	1
Water flow rate CH	(1)	m³/h	18,4	20,3	23,6	26,6	29,3	24,4	28
Pressure drop CH	(1)	kPa	48,6	45,5	38,9	46,4	42,8	20,4	24,7
Noise levels									
Sound power level cooling	(3)	dB(A)	87	90	90	90	90	89	89
Sound pressure level cooling	(4)	dB(A)	69	71	71	71	71	70	70
Dimensions and weights**									
Length		mm	3200	3200	4200	4200	4200	4200	4200
Depth		mm	1100	1100	1100	1100	1100	1100	1100
Height		mm	2150	2150	2150	2150	2150	2150	2150
Operating weight		kg	1384	1410	1788	1813	1839	1749	1755

(1) External air temperature of 35°C and user-side heat exchanger water inlet-outlet temperature of 12-7°C. Values compliant with standard EN 14511

(2) Theoretical values referred to the basic unit. The amount of gas actually charged in the unit may differ.

(3) Unit operating at rated capacity, with no accessories of any kind - external air temperature 35°C and water input/output temperature from/to heat exchanger and user equal to 12/7°C. Values taken by measurements made in accordance with standard ISO 3744 and the Eurovent certification programme, where applicable. Binding values See NOISE LEVELS section.

(4) Values obtained from the sound power level (conditions: note 4), related to a distance of 1 m from the unit in free field with directivity factor Q=2. Non-binding values See NOISE LEVELS section.

(5) Approximate value. The minimum capacity reached by the unit depends on the operating conditions. The value shown may not be suitable for calculating the minimum volume of water: to do this, consult the "Minimum water content in the system" section.

** Basic unit without included accessories

BETA REV RFE /HP

			3.2	4.2	5.2	6.2	7.2	8.2	9.2	10.2
BETA REV RFE /HP										
Cooling										
Refrigeration capacity	(1)	kW	39,91	44,85	52,45	58,82	65,96	80,29	90,44	98,18
Total absorbed power	(1)	kW	14,42	17,28	19,81	21,73	25,36	28,05	33,12	38,86
EER	(1)		2,76	2,59	2,64	2,7	2,6	2,86	2,73	2,52
Heating										
Heating capacity	(2)	kW	41,9	46,91	55,23	63	69,89	83,49	94,49	104,01
Total absorbed power	(2)	kW	13,89	15,96	18,09	20,56	22,61	27,16	30,68	34,3
COP	(2)		3,01	2,93	3,05	3,06	3,09	3,07	3,07	3,03
Compressors										
Compressors/Circuits		n°/n°	2/1	2/1	2/1	2/1	2/1	2/1	2/1	2/1
Minimum capacity reduction step	(7)	%	50	50	50	50	50	50	43	50
HP refrigerant charge (Cu / Al)	(3)	kg	10	11,5	12	20,5	20,5	28,5	29	29
Fans										
Quantity		n°	2	2	2	2	2	3	3	3
Total air flow rate HP		m³/h	17000	17000	15000	19000	19000	28500	28500	28500
User-side heat exchanger										
Quantity		n°	1	1	1	1	1	1	1	1
Water flow rate CH	(1)	m³/h	6,9	7,7	9	10,1	11,4	13,8	15,6	16,9
Pressure drop CH	(1)	kPa	35,4	30,8	32,3	39,7	20,5	30,6	26	30,3
Water flow rate HP	(1)	m³/h	7,2	8	9,5	10,8	12	14,3	16,2	17,8
Pressure drop HP	(1)	kPa	40,7	35,3	37,5	47,3	24,7	35,6	30,5	35,9
Noise levels										
Sound power lev.	(4)	dB(A)	89	89	89	89	89	91	91	91
Sound pressure lev.	(6)	dB(A)	72	72	72	72	72	73	73	73
Sound power lev. LN vers.	(4)	dB(A)	87	87	87	87	87	89	89	89
Sound pressure lev. LN vers.	(6)	dB(A)	70	70	70	70	70	71	71	71
Dimensions and weights**										
Length		mm	1750	1750	1750	2200	2200	3200	3200	3200
Depth		mm	1000	1000	1000	1000	1000	1100	1100	1100
Height		mm	1780	1780	1780	2120	2120	2120	2120	2120
Operating weight		kg	644	655	670	857	887	1282	1294	1308

- (1) External air temperature of 35°C and user-side heat exchanger water inlet-outlet temperature of 12-7°C. Values compliant with standard EN 14511
- (2) Outside air temperature 7°C DB, 6°C WB; condenser inlet/outlet water temperature 40/45°C. Values compliant with standard EN 14511
- (3) Theoretical values referred to the basic unit. The amount of gas actually charged in the unit may differ.
- (4) Unit operating at rated capacity, with no accessories of any kind - external air temperature 35°C and water input/output temperature from/to heat exchanger and user equal to 12/7°C. Values taken by measurements made in accordance with standard ISO 3744 and the Eurovent certification programme, where applicable. Binding values See NOISE LEVELS section.
- (5) unit operating at nominal operating capacity, with no accessories of any kind, with external air temperature of 7°C (6°C WB) and user-side heat exchanger water inlet/outlet temperature of 40/45°C. Values obtained from measurements carried out in accordance with standard ISO 3744.
- (6) Values obtained from the sound power level (conditions: note 4), related to a distance of 1 m from the unit in free field with directivity factor Q=2. Non-binding values See NOISE LEVELS section.
- (7) Approximate value. The minimum capacity reached by the unit depends on the operating conditions. The value shown may not be suitable for calculating the minimum volume of water: to do this, consult the "Minimum water content in the system" section.
- (8) Former Eurovent's seasonal efficiency index. Value not certified by Eurovent from 2019. Reference: base unit, without any accessories
- ** Basic unit without included accessories

BETA REV RFE /HP

			12.2	13.2	15.2	16.2	14.4	16.4	18.4	20.4	24.4
BETA REV RFE /HP											
Cooling											
Refrigeration capacity	(1)	kW	114,08	122,95	141,71	153,36	132,5	148,31	182,73	199,07	224,87
Total absorbed power	(1)	kW	42,54	48,85	55,69	65,15	49,82	60,89	64,55	75,95	88,23
EER	(1)		2,68	2,51	2,54	2,35	2,65	2,43	2,83	2,62	2,54
Heating											
Heating capacity	(2)	kW	121,44	132,55	152,94	167,96	143,06	162,04	193,71	211,44	236,58
Total absorbed power	(2)	kW	39,1	43,34	49,64	55,35	45,6	52,65	60,54	68,12	79,63
COP	(2)		3,1	3,05	3,08	3,03	3,13	3,07	3,19	3,1	2,97
Compressors											
Compressors/Circuits		n°/n°	2/1	2/1	2/1	2/1	4/2	4/2	4/2	4/2	4/2
Minimum capacity reduction step	(7)	%	44	50	45	50	25	25	21	25	22
HP refrigerant charge (Cu / Al)	(3)	kg	30	30	44	44	48	50	64	64	67
Fans											
Quantity		n°	3	3	3	3	3	3	5	5	5
Total air flow rate HP		m³/h	36000	36000	40000	40000	40000	40000	57000	58950	70000
User-side heat exchanger											
Quantity		n°	1	1	1	1	2	2	2	2	2
Water flow rate CH	(1)	m³/h	19,7	21,2	24,4	26,4	22,8	25,6	31,5	34,3	38,7
Pressure drop CH	(1)	kPa	31,8	36,5	31,6	36,7	20,7	25,5	26,5	31,1	30,9
Water flow rate HP	(1)	m³/h	20,8	22,7	26,2	28,8	24,6	27,8	33,3	36,3	40,6
Pressure drop HP	(1)	kPa	37,8	44,4	38,7	46,2	25,4	32	31,3	37	36,1
Noise levels											
Sound power lev.	(4)	dB(A)	94	94	94	94	93	93	96	97	98
Sound pressure lev.	(6)	dB(A)	76	76	76	76	75	75	77	78	79
Sound power lev. LN vers.	(4)	dB(A)	92	92	92	92	91	91	94	95	96
Sound pressure lev. LN vers.	(6)	dB(A)	74	74	74	74	73	73	75	76	77
Dimensions and weights**											
Length		mm	3200	3200	3200	3200	3200	3200	4200	4200	4200
Depth		mm	1100	1100	1100	1100	1100	1100	1100	1100	1100
Height		mm	2120	2120	2150	2150	2150	2150	2150	2150	2150
Operating weight		kg	1378	1418	1598	1656	1588	1736	2168	2200	2276

- (1) External air temperature of 35°C and user-side heat exchanger water inlet-outlet temperature of 12-7°C. Values compliant with standard EN 14511
- (2) Outside air temperature 7°C DB, 6°C WB; condenser inlet/outlet water temperature 40/45°C. Values compliant with standard EN 14511
- (3) Theoretical values referred to the basic unit. The amount of gas actually charged in the unit may differ.
- (4) Unit operating at rated capacity, with no accessories of any kind - external air temperature 35°C and water input/output temperature from/to heat exchanger and user equal to 12/7°C. Values taken by measurements made in accordance with standard ISO 3744 and the Eurovent certification programme, where applicable. Binding values See NOISE LEVELS section.
- (5) unit operating at nominal operating capacity, with no accessories of any kind, with external air temperature of 7°C (6°C WB) and user-side heat exchanger water inlet/outlet temperature of 40/45°C. Values obtained from measurements carried out in accordance with standard ISO 3744.
- (6) Values obtained from the sound power level (conditions: note 4), related to a distance of 1 m from the unit in free field with directivity factor Q=2. Non-binding values See NOISE LEVELS section.
- (7) Approximate value. The minimum capacity reached by the unit depends on the operating conditions. The value shown may not be suitable for calculating the minimum volume of water: to do this, consult the "Minimum water content in the system" section.
- (8) Former Eurovent's seasonal efficiency index. Value not certified by Eurovent from 2019. Reference: base unit, without any accessories
- ** Basic unit without included accessories

BETA REV RFE SLN /HP

			3.2	4.2	5.2	6.2	7.2	8.2	9.2
BETA REV RFE SLN /HP									
Cooling									
Refrigeration capacity	(1)	kW	39,25	44,27	50,15	60,12	68,16	81,39	91,99
Total absorbed power	(1)	kW	13,85	16,9	20,21	20,24	23,8	27,29	32,33
EER	(1)		2,83	2,62	2,48	2,97	2,86	2,98	2,84
Heating									
Heating capacity	(2)	kW	41,85	48,61	55,55	63,36	70,69	88,66	99,46
Total absorbed power	(2)	kW	12,74	14,76	17,14	19,23	21,45	26,1	29,59
COP	(2)		3,28	3,29	3,24	3,29	3,29	3,39	3,36
Compressors									
Compressors/Circuits		n°/n°	2/1	2/1	2/1	2/1	2/1	2/1	2/1
Minimum capacity reduction step	(7)	%	50	50	50	50	50	50	43
HP refrigerant charge (Cu / Al)	(3)	kg	12	13	21	31	31	31	31
Fans									
Quantity		n°	2	2	2	3	3	3	3
Total air flow CH		m³/h	13000	13000	13000	19500	19500	32000	32000
Total air flow rate HP		m³/h	13000	13000	13000	19500	19500	32000	32000
User-side heat exchanger									
Quantity		n°	1	1	1	1	1	1	1
Water flow rate CH	(1)	m³/h	6,8	7,6	8,6	10,4	11,7	14	15,9
Pressure drop CH	(1)	kPa	20,9	18,6	23,3	23,6	28,3	40,9	37,1
Water flow rate HP	(1)	m³/h	7,2	8,3	9,5	10,9	12,1	15,2	17,1
Pressure drop HP	(1)	kPa	22,6	20,2	27,2	24,1	30,6	44,5	40,6
Noise levels									
Sound power lev.	(4)	dB(A)	85	85	85	85	85	87	87
Sound pressure lev.	(6)	dB(A)	68	68	68	67	67	69	69
Dimensions and weights**									
Length		mm	1750	1750	2200	3200	3200	3200	3200
Depth		mm	1000	1000	1000	1100	1100	1100	1100
Height		mm	1780	1780	2120	2120	2120	2120	2120
Operating weight		kg	450	461	659	857	867	977	1053

(1) External air temperature of 35°C and user-side heat exchanger water inlet-outlet temperature of 12-7°C. Values compliant with standard EN 14511

(2) Outside air temperature 7°C DB, 6°C WB; condenser inlet/outlet water temperature 40/45°C. Values compliant with standard EN 14511

(3) Theoretical values referred to the basic unit. The amount of gas actually charged in the unit may differ.

(4) Unit operating at rated capacity, with no accessories of any kind - external air temperature 35°C and water input/output temperature from/to heat exchanger and user equal to 12/7°C. Values taken by measurements made in accordance with standard ISO 3744 and the Eurovent certification programme, where applicable. Binding values See NOISE LEVELS section.

(5) unit operating at nominal operating capacity, with no accessories of any kind, with external air temperature of 7°C (6°C WB) and user-side heat exchanger water inlet/outlet temperature of 40/45°C. Values obtained from measurements carried out in accordance with standard ISO 3744.

(6) Values obtained from the sound power level (conditions: note 4), related to a distance of 1 m from the unit in free field with directivity factor Q=2. Non-binding values See NOISE LEVELS section.

(7) Approximate value. The minimum capacity reached by the unit depends on the operating conditions. The value shown may not be suitable for calculating the minimum volume of water: to do this, consult the "Minimum water content in the system" section.

(8) Former Eurovent's seasonal efficiency index. Value not certified by Eurovent from 2019. Reference: base unit, without any accessories

** Basic unit without included accessories

BETA REV RFE SLN /HP

			10.2	12.2	13.2	15.2	16.2	14.4	16.4
BETA REV RFE SLN /HP									
Cooling									
Refrigeration capacity	(1)	kW	102,44	112,47	132,17	148,41	163,53	137,7	157,39
Total absorbed power	(1)	kW	36,61	42,98	44,24	51,95	60,42	46,74	56,94
EER	(1)		2,8	2,62	2,99	2,86	2,71	2,95	2,76
Heating									
Heating capacity	(2)	kW	109,75	124	142,92	160,47	178,84	148,55	170,57
Total absorbed power	(2)	kW	33,24	37,32	42,28	47,83	53,26	43,86	50,86
COP	(2)		3,3	3,32	3,38	3,35	3,35	3,38	3,35
Compressors									
Compressors/Circuits		n°/n°	2/1	2/1	2/1	2/1	2/1	4/2	4/2
Minimum capacity reduction step	(7)	%	50	44	50	45	50	25	25
HP refrigerant charge (Cu / Al)	(3)	kg	43	43,5	57	57	58	64	64
Fans									
Quantity		n°	3	3	5	5	5	5	5
Total air flow CH		m³/h	32000	32000	48000	48000	48000	48000	48000
Total air flow rate HP		m³/h	32000	32000	48000	48000	48000	48000	48000
User-side heat exchanger									
Quantity		n°	1	1	1	1	1	2	2
Water flow rate CH	(1)	m³/h	17,7	19,4	22,8	25,6	28,2	23,7	27,1
Pressure drop CH	(1)	kPa	45,3	42	36,5	43,4	39,7	29,9	37,1
Water flow rate HP	(1)	m³/h	18,8	21,3	24,5	27,5	30,7	25,5	29,3
Pressure drop HP	(1)	kPa	49,4	47,1	39,3	48,5	45,1	32,5	42
Noise levels									
Sound power lev.	(4)	dB(A)	87	90	90	90	90	89	89
Sound pressure lev.	(6)	dB(A)	69	71	71	71	71	70	70
Dimensions and weights**									
Length		mm	3200	3200	4200	4200	4200	4200	4200
Depth		mm	1100	1100	1100	1100	1100	1100	1100
Height		mm	2150	2150	2150	2150	2150	2150	2150
Operating weight		kg	1294	1350	1571	1613	1636	1532	1554

- (1) External air temperature of 35°C and user-side heat exchanger water inlet-outlet temperature of 12-7°C. Values compliant with standard EN 14511
- (2) Outside air temperature 7°C DB, 6°C WB; condenser inlet/outlet water temperature 40/45°C. Values compliant with standard EN 14511
- (3) Theoretical values referred to the basic unit. The amount of gas actually charged in the unit may differ.
- (4) Unit operating at rated capacity, with no accessories of any kind - external air temperature 35°C and water input/output temperature from/to heat exchanger and user equal to 12/7°C. Values taken by measurements made in accordance with standard ISO 3744 and the Eurovent certification programme, where applicable. Binding values See NOISE LEVELS section.
- (5) unit operating at nominal operating capacity, with no accessories of any kind, with external air temperature of 7°C (6°C WB) and user-side heat exchanger water inlet/outlet temperature of 40/45°C. Values obtained from measurements carried out in accordance with standard ISO 3744.
- (6) Values obtained from the sound power level (conditions: note 4), related to a distance of 1 m from the unit in free field with directivity factor Q=2. Non-binding values See NOISE LEVELS section.
- (7) Approximate value. The minimum capacity reached by the unit depends on the operating conditions. The value shown may not be suitable for calculating the minimum volume of water: to do this, consult the "Minimum water content in the system" section.
- (8) Former Eurovent's seasonal efficiency index. Value not certified by Eurovent from 2019. Reference: base unit, without any accessories
- ** Basic unit without included accessories

ECODESIGN

INTRODUCTION

The Ecodesign/ErP Directive (2009/125/EC) lays down new standards for more efficient energy use.

The Directive contains various regulations; as regards chiller products and heat pumps, the regulations of interest are the following:

- Regulation 2013/813, for small heat pumps ($P_{\text{design}} \leq 400$ kW)
- Regulation 2016/2281, for chillers and heat pumps with $P_{\text{design}} > 400$ kW
- Regulation 2013/811, for heat pumps with $P_{\text{design}} \leq 70$ kW.

The last-mentioned regulation (2013/811) regards the labelling (Ecolabel certification) of small heat pumps.

The other two regulations (2013/813 and 2016/2281) set seasonal efficiency targets that the products must comply with to be sold and installed in the European Union (essential requirement for CE marking).

These efficiency limits are defined through ratios, which are respectively:

- η_{sh} (SCOP), with reference to regulation 2013/813
- η_{sc} (SEER) for comfort applications and SEPR for process applications, with reference to regulation 2016/2281.

As regards regulation 2016/2281, with effect from 1st January 2021, the required minimum efficiency limit will be raised (Tier 2) from the current threshold (Tier 1).

The figure below schematically illustrates the correspondence between product and reference energy ratio.

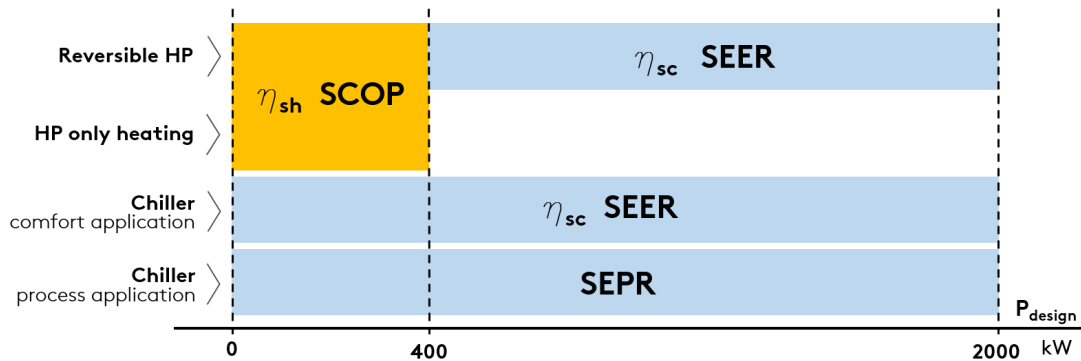

Some notes and clarifications:

For comfort applications, regulation 2016/2281 sets the η_{sc} (SEER) ratio in two different operating conditions:

- SEER calculated with machine inlet/outlet water temperature of 12/7°C (low temperature application),
- SEER calculated with machine inlet/outlet water temperature of 23/18°C (medium temperature application).

The minimum efficiency requirement is the same, but can be met at condition 12/7°C or at condition 23/18°C, depending on the application envisaged for the machine.

Regulation 2013/813 distinguishes two different types: at low temperature and at medium temperature.

The following refer to the application at low temperature: (low temperature application) all heat pumps whose maximum delivery temperature for heating purposes is lower than 52°C with source at temperature of -7°C and -8°C wet bulb (air-water unit) or inlet 10°C (water-water unit), at the reference design conditions for an average climate. For these, the efficiency ratio is "low temperature application" (outlet water temperature 35°C).

For all the other heat pumps, the efficiency ratio is related to "medium temperature application" (outlet water temperature 55°C).

The ratios must be calculated according to the reference European heating season in average climatic conditions.

The minimum efficiency requirements set by the regulations are indicated below.

REGULATION 2016/2281, comfort application

TYPE OF UNIT		MINIMUM REQUIREMENT			
		Tier 1		Tier 2 (2021)	
SOURCE	P _{design}	η _{sc} [%]	SEER	η _{sc} [%]	SEER
air	< 400kW	149	3,8	161	4,1
air	≥ 400kW	161	4,1	179	4,55
water	< 400kW	196	4,975	200	5,075
water	≥ 400kW and < 1500kW	227	5,75	252	6,375
water	≥ 1500kW	245	6,2	272	6,875

REGULATION 2016/2281, process application

TYPE OF UNIT		MINIMUM REQUIREMENT	
		Tier 1	Tier 2 (2021)
SOURCE	P _{design}	SEPR	SEPR
air	< 400kW	4,5	5
air	≥ 400kW	5	5,5
water	< 400kW	6,5	7
water	≥ 400kW and < 1500kW	7,5	8
water	≥ 1500kW	8	8,5

REGULATION 2013/813

SOURCE	APPLICATION	MINIMUM REQUIREMENT	
		η _{sh} [%]	SCOP
air	low temperature application	125	3,2
water	low temperature application	125	3,325
air	medium temperature application	110	2,825
water	medium temperature application	110	2,95

The conformity of the product must be checked according to the type of application, whether comfort or process, and at the required outlet water temperature.

The two schematic tables below, respectively for comfort application and for process application, indicate the reference of the required conformity according to the type of product and the set point temperature (reference to regulations 2016/2281 and 2013/813).

Important note: for mixed comfort and process applications, the reference application for conformity is the comfort application.

COMFORT APPLICATION

PRODUCT	OUTLET WATER TEMPERATURE	COMPLIANCE INDEX	REGULATION
Chiller	< 18°C	SEER/η _{sc} low temperature application	2016/2281
	≥ 18°C	SEER/η _{sc} medium temperature application	2016/2281
Heat pumps (reversible and only heating) P_{design} ≤ 400kW		SCOP/η _{sh}	2013/813
Reversible heat pumps P_{design} > 400kW	< 18°C	SEER/η _{sc} low temperature application	2016/2281
	≥ 18°C	SEER/η _{sc} medium temperature application	2016/2281
Heat pumps only heating P_{design} > 400kW		-	-

- = exemption from Ecodesign

PROCESS APPLICATION

PRODUCT	OUTLET WATER TEMPERATURE	COMPLIANCE INDEX	REGULATION
Chiller	≥ +2°C , ≤ 12°C	SEPR	2016/2281
	> 12°C	-	-
	> -8°C , < +2°C	-	-

- = exemption from Ecodesign

Some specifications and notes follow.

Partly completed machinery

The term partly completed machinery refers to all units without a user-side or source-side heat exchanger, and therefore to all LC, LE, LC/HP and LE/HP versions. Since these are "non-complete" machines, conformity with Ecodesign depends on combination with the remote heat exchanger.

All the partly completed machinery is CE marked and accompanied by a declaration of conformity. Installation in European Union countries is therefore allowed; correct selection and installation of the remote heat exchanger must be ensured, in accordance with the above cases.

EC fans:

The only option that positively affects the performance of the unit, by increasing its seasonal energy efficiency ratio, is the VEC accessory.

A unit equipped with EC fans has a higher SEER (η_{sc}) than the configuration with standard fans.

BETA REV RANGE

As regards, specifically, the Beta Rev range, here below the regulations of interest for the different units in the different configurations.

Beta Rev RFE:

- chiller version: regulation 2016/2281
- /HP version: regulation 2013/813 (since they are all units with Pdesign ≤ 400 kW).

Beta Rev RFE HE:

- chiller version: regulation 2016/2281

Beta Rev RFE SLN:

- chiller version: regulation 2016/2281
- /HP version: regulation 2013/813 (since they are all units with Pdesign ≤ 400 kW).

The tables below give information on the conformity of the units and the seasonal energy performance ratios with regard to the reference regulation.

BETA REV RFE

			3.2	4.2	5.2	6.2	7.2	8.2	9.2	10.2
REGULATION 2016/2281										
Pdesign	(1)	kW	40,5	45,4	53,08	59,8	66,82	81,1	93,01	102,1
COMFORT										
Standard units										
η _{sc} (12/7)	(1)	%	149,1	149,1	149,1	153,5	151,2	153,6	156,1	153,2
SEER (12/7)	(1)		3,8	3,8	3,8	3,91	3,85	3,92	3,98	3,91
Compliance Tier 1	(1)		Y	Y	Y	Y	Y	Y	Y	Y
Compliance Tier 2 (2021)	(1)		N	N	N	N	N	N	N	N
PROCESS										
SEPR	(3)		5,61	5,19	5,35	5,56	5,18	5,56	5,54	5,31
Compliance Tier 1	(3)		Y	Y	Y	Y	Y	Y	Y	Y
Compliance Tier 2 (2021)	(3)		Y	Y	Y	Y	Y	Y	Y	Y

Y = unit in compliance with Ecodesign at the indicated condition.

N = unit not in compliance with Ecodesign at the given condition: it can be installed only in non-EU countries.

- (1) User-side heat exchanger water inlet/outlet temperature 12/7°C (low temperature application), with reference to regulation 2016/2281 and standard EN 14825.
- (2) User-side heat exchanger water inlet/outlet temperature 23/18°C (medium temperature application), with reference to regulation 2016/2281 and standard EN 14825.
- (3) User-side heat exchanger water inlet/outlet temperature 12/7°C, with reference to regulation 2016/2281 and norm EN 14825.

BETA REV RFE

			12.2	13.2	15.2	16.2	14.4	16.4	18.4	20.4	24.4
REGULATION 2016/2281											
Pdesign	(1)	kW	116,42	125,39	146,48	159,5	136,97	153,64	189,6	208,13	233,77
COMFORT											
Standard units											
η _{sc} (12/7)	(1)	%	150,8	149,3	155,7	154,8	149	149,1	167,4	162,92	161,04
SEER (12/7)	(1)		3,84	3,81	3,94	3,8	3,97	3,8	4,26	4,15	4,1
Compliance Tier 1	(1)		Y	Y	Y	Y	Y	Y	Y	Y	Y
Compliance Tier 2 (2021)	(1)		N	N	N	N	N	N	Y	Y	Y
PROCESS											
SEPR	(3)		5,34	5,13	5,37	5,32	5,05	5,24	5,67	5,54	5,44
Compliance Tier 1	(3)		Y	Y	Y	Y	Y	Y	Y	Y	Y
Compliance Tier 2 (2021)	(3)		Y	Y	Y	Y	Y	Y	Y	Y	Y

Y = unit in compliance with Ecodesign at the indicated condition.

N = unit not in compliance with Ecodesign at the given condition: it can be installed only in non-EU countries.

- (1) User-side heat exchanger water inlet/outlet temperature 12/7°C (low temperature application), with reference to regulation 2016/2281 and standard EN 14825.
- (2) User-side heat exchanger water inlet/outlet temperature 23/18°C (medium temperature application), with reference to regulation 2016/2281 and standard EN 14825.
- (3) User-side heat exchanger water inlet/outlet temperature 12/7°C, with reference to regulation 2016/2281 and norm EN 14825.

BETA REV RFE HE

			3.2	4.2	5.2	6.2	7.2	8.2	9.2
REGULATION 2016/2281									
Pdesign	(1)	kW	42,49	49,28	58,39	63,48	72,36	87,39	100,89
COMFORT									
Standard units									
η_{sc} (12/7)	(1)	%	166	166,8	161	168,6	166,8	163	167,1
SEER (12/7)	(1)		4,23	4,24	4,1	4,29	4,24	4,15	4,25
Compliance Tier 1	(1)		Y	Y	Y	Y	Y	Y	Y
Compliance Tier 2 (2021)	(1)		Y	Y	Y	Y	Y	Y	Y
PROCESS									
SEPR	(3)		-	-	-	-	-	-	-
Compliance Tier 1	(3)		Y	Y	Y	Y	Y	Y	Y
Compliance Tier 2 (2021)	(3)		Y	Y	Y	Y	Y	Y	Y

Y = unit in compliance with Ecodesign at the indicated condition.

N = unit not in compliance with Ecodesign at the given condition: it can be installed only in non-EU countries.

- (1) User-side heat exchanger water inlet/outlet temperature 12/7°C (low temperature application), with reference to regulation 2016/2281 and standard EN 14825.
- (2) User-side heat exchanger water inlet/outlet temperature 23/18°C (medium temperature application), with reference to regulation 2016/2281 and standard EN 14825.
- (3) User-side heat exchanger water inlet/outlet temperature 12/7°C, with reference to regulation 2016/2281 and norm EN 14825.

BETA REV RFE HE

			10.2	12.2	13.2	15.2	16.2	14.4	16.4
REGULATION 2016/2281									
Pdesign	(1)	kW	111,14	127,98	139,25	159,12	179,98	144,84	171,62
COMFORT									
Standard units									
η_{sc} (12/7)	(1)	%	169	167,8	170,6	169,8	166,1	169,8	162,6
SEER (12/7)	(1)		4,3	4,27	4,34	4,32	4,23	4,32	4,14
Compliance Tier 1	(1)		Y	Y	Y	Y	Y	Y	Y
Compliance Tier 2 (2021)	(1)		Y	Y	Y	Y	Y	Y	Y
PROCESS									
SEPR	(3)		-	-	-	-	-	-	-
Compliance Tier 1	(3)		Y	Y	Y	Y	Y	Y	Y
Compliance Tier 2 (2021)	(3)		Y	Y	Y	Y	Y	Y	Y

Y = unit in compliance with Ecodesign at the indicated condition.

N = unit not in compliance with Ecodesign at the given condition: it can be installed only in non-EU countries.

- (1) User-side heat exchanger water inlet/outlet temperature 12/7°C (low temperature application), with reference to regulation 2016/2281 and standard EN 14825.
- (2) User-side heat exchanger water inlet/outlet temperature 23/18°C (medium temperature application), with reference to regulation 2016/2281 and standard EN 14825.
- (3) User-side heat exchanger water inlet/outlet temperature 12/7°C, with reference to regulation 2016/2281 and norm EN 14825.

BETA REV RFE SLN

			3.2	4.2	5.2	6.2	7.2	8.2	9.2
REGULATION 2016/2281									
Pdesign	(1)	kW	40,8	46,2	52,5	62,4	70,9	83,4	94,6
COMFORT									
Standard units									
η_{sc} (12/7)	(1)	%	161,28	161,04	155,68	167	161,84	161,04	161,04
SEER (12/7)	(1)		4,1	4,1	3,96	4,25	4,12	4,1	4,1
Compliance Tier 1	(1)		Y	Y	Y	Y	Y	Y	Y
Compliance Tier 2 (2021)	(1)		Y	Y	N	Y	Y	Y	Y
PROCESS									
SEPR	(3)		5,61	5,19	5,35	5,56	5,18	5,56	5,54
Compliance Tier 1	(3)		Y	Y	Y	Y	Y	Y	Y
Compliance Tier 2 (2021)	(3)		Y	Y	Y	Y	Y	Y	Y

Y = unit in compliance with Ecodesign at the indicated condition.

N = unit not in compliance with Ecodesign at the given condition: it can be installed only in non-EU countries.

- (1) User-side heat exchanger water inlet/outlet temperature 12/7°C (low temperature application), with reference to regulation 2016/2281 and standard EN 14825.
- (2) User-side heat exchanger water inlet/outlet temperature 23/18°C (medium temperature application), with reference to regulation 2016/2281 and standard EN 14825.
- (3) User-side heat exchanger water inlet/outlet temperature 12/7°C, with reference to regulation 2016/2281 and norm EN 14825.

BETA REV RFE SLN

			10.2	12.2	13.2	15.2	16.2	14.4	16.4
REGULATION 2016/2281									
Pdesign	(1)	kW	106,5	117,5	136,9	154,1	170,2	141,9	162,5
COMFORT									
Standard units									
η_{sc} (12/7)	(1)	%	166,76	164,6	168,72	168,88	164,2	161,04	161,8
SEER (12/7)	(1)		4,24	4,19	4,29	4,29	4,18	4,1	4,12
Compliance Tier 1	(1)		Y	Y	Y	Y	Y	Y	Y
Compliance Tier 2 (2021)	(1)		Y	Y	Y	Y	Y	Y	Y
PROCESS									
SEPR	(3)		5,31	5,34	5,13	5,37	5,32	5,05	5,24
Compliance Tier 1	(3)		Y	Y	Y	Y	Y	Y	Y
Compliance Tier 2 (2021)	(3)		Y	Y	Y	Y	Y	Y	Y

Y = unit in compliance with Ecodesign at the indicated condition.

N = unit not in compliance with Ecodesign at the given condition: it can be installed only in non-EU countries.

- (1) User-side heat exchanger water inlet/outlet temperature 12/7°C (low temperature application), with reference to regulation 2016/2281 and standard EN 14825.
- (2) User-side heat exchanger water inlet/outlet temperature 23/18°C (medium temperature application), with reference to regulation 2016/2281 and standard EN 14825.
- (3) User-side heat exchanger water inlet/outlet temperature 12/7°C, with reference to regulation 2016/2281 and norm EN 14825.

BETA REV RFE /HP

			3.2	4.2	5.2	6.2	7.2	8.2	9.2	10.2
REGULATION 2013/813										
Pdesign	(4)	kW	-	-	-	-	-	-	-	-
COMFORT										
Low temperature application										
ηsh	(4)	%	130,2	133,1	137,8	135,9	138,6	134,9	136,3	133,2
SCOP	(4)		3,33	3,4	3,52	3,47	3,54	3,45	3,48	3,41
Conformity with Tier 2	(4)		Y	Y	Y	Y	Y	Y	Y	Y
REGULATION 2013/811										
Ecolabel	(5)		A++	A++	A++	A++	A++	-	-	-

Y = unit in compliance with Ecodesign at the indicated condition.

(4) User-side heat exchanger water inlet/outlet temperature 30/35, Average climate profile, with reference to regulation 2013/813 and norm EN 14825.

(5) Energy efficiency class with reference to regulation 2013/811, note 4 conditions (low temperature applications).

BETA REV RFE /HP

			12.2	13.2	15.2	16.2	14.4	16.4	18.4	20.4	24.4
REGULATION 2013/813											
Pdesign	(4)	kW	-	-	-	-	-	-	-	-	-
COMFORT											
Low temperature application											
ηsh	(4)	%	128,4	128,4	134,6	132,2	130,4	130,4	139	129,6	125,5
SCOP	(4)		3,28	3,29	3,44	3,38	3,34	3,34	3,55	3,32	3,21
Conformity with Tier 2	(4)		Y	Y	Y	Y	Y	Y	Y	Y	Y
REGULATION 2013/811											
Ecolabel	(5)		-	-	-	-	-	-	-	-	-

Y = unit in compliance with Ecodesign at the indicated condition.

(4) User-side heat exchanger water inlet/outlet temperature 30/35, Average climate profile, with reference to regulation 2013/813 and norm EN 14825.

(5) Energy efficiency class with reference to regulation 2013/811, note 4 conditions (low temperature applications).

BETA REV RFE SLN /HP

			3.2	4.2	5.2	6.2	7.2	8.2	9.2
REGULATION 2013/813									
Pdesign	(4)	kW	-	-	-	-	-	-	-
COMFORT									
Low temperature application									
ηsh	(4)	%	130,2	133,1	137,8	135,9	138,6	134,9	136,3
SCOP	(4)		3,42	3,45	3,55	3,55	3,56	3,22	3,33
Conformity with Tier 2	(4)		Y	Y	Y	Y	Y	Y	Y
REGULATION 2013/811									
Ecolabel	(5)		A++	A++	A++	A++	A++	-	-

Y = unit in compliance with Ecodesign at the indicated condition.

(4) User-side heat exchanger water inlet/outlet temperature 30/35, Average climate profile, with reference to regulation 2013/813 and norm EN 14825.

(5) Energy efficiency class with reference to regulation 2013/811, note 4 conditions (low temperature applications).

BETA REV RFE SLN /HP

			10.2	12.2	13.2	15.2	16.2	14.4	16.4
REGULATION 2013/813									
Pdesign	(4)	kW	-	-	-	-	-	-	-
COMFORT									
Low temperature application									
ηsh	(4)	%	133,2	128,4	128,4	134,6	132,2	130,4	130,4
SCOP	(4)		3,37	3,52	3,48	3,54	3,53	3,43	3,47
Conformity with Tier 2	(4)		Y	Y	Y	Y	Y	Y	Y
REGULATION 2013/811									
Ecolabel	(5)		-	-	-	-	-	-	-

Y = unit in compliance with Ecodesign at the indicated condition.

(4) User-side heat exchanger water inlet/outlet temperature 30/35, Average climate profile, with reference to regulation 2013/813 and norm EN 14825.

(5) Energy efficiency class with reference to regulation 2013/811, note 4 conditions (low temperature applications).

ELECTRICAL SPECIFICATIONS

BETA REV RFE

			3.2	4.2	5.2	6.2	7.2	8.2	9.2	10.2
General electrical specifications										
Max. absorbed power (FLI)	(1)	kW	22,9	26,0	28,9	31,8	35,1	42,6	47,0	51,3
Max. absorbed current (FLA)	(1)	A	41,3	50,9	52,1	58,9	70,9	81,3	85,5	89,7
Rated current (Inom)	(2)	A	-	-	-	-	-	-	-	-
cosφ standard unit	(2)		-	-	-	-	-	-	-	-
Nominal current with power factor correction (Inom)	(2)	A	-	-	-	-	-	-	-	-
cosφ unit with power factor correction	(2)		-	-	-	-	-	-	-	-
Max. inrush current (MIC)	(3)	A	126	141	170	152	180	221	288	292
Maximum inrush current with soft-starter (MIC)	(4)	A	86	97	114	105	124	152	192	196
Power supply		V/ph/Hz	400/3~/50	400/3~/51	400/3~/52	400/3~/53	400/3~/54	400/3~/55	400/3~/56	400/3~/57
Power supply for auxiliary circuits		V/ph/Hz	230- 24/1~/50	230- 24/1~/51	230- 24/1~/52	230- 24/1~/53	230- 24/1~/54	230- 24/1~/55	230- 24/1~/56	230- 24/1~/57
Suggested line section	(5)	mm ²	-	-	-	-	-	-	-	-
Suggested line protection	(6)		-	-	-	-	-	-	-	-
Electrical specifications for fans										
Rated power of fan standard		n° x kW	2 x 3,1	2 x 3,1	2 x 3,1	2 x 3,1	2 x 3,1	3 x 3,1	3 x 3,1	3 x 3,1
Rated current of fan standard		n° x A	2 x 4,8	2 x 4,8	2 x 4,8	2 x 4,8	2 x 4,8	3 x 4,8	3 x 4,8	3 x 4,8

- (1) Data regarding the unit without accessories working in maximum power absorption conditions
- (2) Datum related to the unit without accessories working in standard conditions (A35°C; W12/7°C)
- (3) Maximum effective RMS value of the current when the last compressor starts (FLA of the entire unit - FLA of the largest compressor + LRA of the largest compressor)
- (4) Maximum effective RMS value of the current when the last compressor starts (FLA of the entire unit - FLA of the largest compressor + 0.6 x LRA of the largest compressor)
- (5) These values are determined for cables with operating temperature of 40°C, EPR insulation and a line with a maximum length of 50m. The line section must be determined by a qualified technician based on the protection devices, the length of the line, the type of cable used and the type of installation.
- (6) The correct line protection part must be determined by a qualified technician based on the length of the line, the type of cable used and the type of installation.

BETA REV RFE

			12.2	13.2	15.2	16.2	14.4	16.4	18.4	20.4	24.4
General electrical specifications											
Max. absorbed power (FLI)	(1)	kW	56,1	61,5	70,9	80,3	66,7	75,9	90,0	98,7	109,5
Max. absorbed current (FLA)	(1)	A	99,1	109,5	126,3	143,1	136,3	148,3	164,9	173,3	194,1
Rated current (Inom)	(2)	A	-	-	-	-	-	-	-	-	-
cosφ standard unit	(2)		-	-	-	-	-	-	-	-	-
Nominal current with power factor correction (Inom)	(2)	A	-	-	-	-	-	-	-	-	-
cosφ unit with power factor correction	(2)		-	-	-	-	-	-	-	-	-
Max. inrush current (MIC)	(3)	A	338	348	371	388	245	288	368	376	433
Maximum inrush current with soft-starter (MIC)	(4)	A	223	233	247	264	189	219	271	280	318
Power supply		V/ph/Hz	400/3~/58	400/3~/59	400/3~/60	400/3~/61	400/3~/62	400/3~/63	400/3~/64	400/3~/65	400/3~/66
Power supply for auxiliary circuits		V/ph/Hz	230- 24/1~/58	230- 24/1~/59	230- 24/1~/60	230- 24/1~/61	230- 24/1~/62	230- 24/1~/63	230- 24/1~/64	230- 24/1~/65	230- 24/1~/66
Suggested line section	(5)	mm ²	-	-	-	-	-	-	-	-	-
Suggested line protection	(6)		-	-	-	-	-	-	-	-	-
Electrical specifications for fans											
Rated power of fan standard		n° x kW	3 x 3,7	3 x 3,7	3 x 3,7	3 x 3,7	3 x 3,7	3 x 3,7	5 x 3,7	5 x 3,7	5 x 3,7
Rated current of fan standard		n° x A	3 x 5,7	3 x 5,7	3 x 5,7	3 x 5,7	3 x 5,7	3 x 5,7	5 x 5,7	5 x 5,7	5 x 5,7

- (1) Data regarding the unit without accessories working in maximum power absorption conditions
- (2) Datum related to the unit without accessories working in standard conditions (A35°C; W12/7°C)
- (3) Maximum effective RMS value of the current when the last compressor starts (FLA of the entire unit - FLA of the largest compressor + LRA of the largest compressor)
- (4) Maximum effective RMS value of the current when the last compressor starts (FLA of the entire unit - FLA of the largest compressor + 0.6 x LRA of the largest compressor)
- (5) These values are determined for cables with operating temperature of 40°C, EPR insulation and a line with a maximum length of 50m. The line section must be determined by a qualified technician based on the protection devices, the length of the line, the type of cable used and the type of installation.
- (6) The correct line protection part must be determined by a qualified technician based on the length of the line, the type of cable used and the type of installation.

BETA REV RFE HE

			3.2	4.2	5.2	6.2	7.2	8.2	9.2
General electrical specifications									
Max. absorbed power (FLI)	(1)	kW	22,9	26,0	28,9	34,7	38,0	42,0	46,4
Max. absorbed current (FLA)	(1)	A	41,3	50,9	52,1	63,3	75,3	80,3	84,5
Rated current (Inom)	(2)	A	-	-	-	-	-	-	-
cosφ standard unit	(2)		-	-	-	-	-	-	-
Nominal current with power factor correction (Inom)	(2)	A	-	-	-	-	-	-	-
cosφ unit with power factor correction	(2)		-	-	-	-	-	-	-
Max. inrush current (MIC)	(3)	A	126	141	170	156	184	220	287
Maximum inrush current with soft-starter (MIC)	(4)	A	86	97	114	109	128	151	191
Power supply		V/ph/Hz	400/3~/50	400/3~/50	400/3~/50	400/3~/50	400/3~/50	400/3~/50	400/3~/50
Power supply for auxiliary circuits		V/ph/Hz	230- 24/1~/50	230- 24/1~/50	230- 24/1~/50	230- 24/1~/50	230- 24/1~/50	230- 24/1~/50	230- 24/1~/50
Suggested line section	(5)	mm ²	-	-	-	-	-	-	-
Suggested line protection	(6)		-	-	-	-	-	-	-
Electrical specifications for fans									
Rated power of fan standard		n° x kW	2 x 2,9	2 x 2,9	2 x 2,9	3 x 2,9	3 x 2,9	3 x 2,7	3 x 2,7
Rated current of fan standard		n° x A	2 x 4,4	2 x 4,4	2 x 4,4	3 x 4,4	3 x 4,4	3 x 4,1	3 x 4,1

- (1) Data regarding the unit without accessories working in maximum power absorption conditions
- (2) Datum related to the unit without accessories working in standard conditions (A35°C; W12/7°C)
- (3) Maximum effective RMS value of the current when the last compressor starts (FLA of the entire unit - FLA of the largest compressor + LRA of the largest compressor)
- (4) Maximum effective RMS value of the current when the last compressor starts (FLA of the entire unit - FLA of the largest compressor + 0.6 x LRA of the largest compressor)
- (5) These values are determined for cables with operating temperature of 40°C, EPR insulation and a line with a maximum length of 50m. The line section must be determined by a qualified technician based on the protection devices, the length of the line, the type of cable used and the type of installation.
- (6) The correct line protection part must be determined by a qualified technician based on the length of the line, the type of cable used and the type of installation.

BETA REV RFE HE

			10.2	12.2	13.2	15.2	16.2	14.4	16.4
General electrical specifications									
Max. absorbed power (FLI)	(1)	kW	50,7	56,1	66,9	76,3	85,7	72,1	81,3
Max. absorbed current (FLA)	(1)	A	88,7	99,1	117,7	134,5	151,3	144,5	156,5
Rated current (Inom)	(2)	A	-	-	-	-	-	-	-
cosφ standard unit	(2)		-	-	-	-	-	-	-
Nominal current with power factor correction (Inom)	(2)	A	-	-	-	-	-	-	-
cosφ unit with power factor correction	(2)		-	-	-	-	-	-	-
Max. inrush current (MIC)	(3)	A	291	338	357	379	396	254	297
Maximum inrush current with soft-starter (MIC)	(4)	A	195	223	242	255	272	198	227
Power supply		V/ph/Hz	400/3~/50	400/3~/50	400/3~/50	400/3~/50	400/3~/50	400/3~/50	400/3~/50
Power supply for auxiliary circuits		V/ph/Hz	230- 24/1~/50	230- 24/1~/50	230- 24/1~/50	230- 24/1~/50	230- 24/1~/50	230- 24/1~/50	230- 24/1~/50
Suggested line section	(5)	mm ²	-	-	-	-	-	-	-
Suggested line protection	(6)		-	-	-	-	-	-	-
Electrical specifications for fans									
Rated power of fan standard		n° x kW	3 x 2,7	3 x 2,7	5 x 2,7	5 x 2,7	5 x 2,7	5 x 2,7	5 x 2,7
Rated current of fan standard		n° x A	3 x 4,1	3 x 4,1	5 x 4,1	5 x 4,1	5 x 4,1	5 x 4,1	5 x 4,1

- (1) Data regarding the unit without accessories working in maximum power absorption conditions
- (2) Datum related to the unit without accessories working in standard conditions (A35°C; W12/7°C)
- (3) Maximum effective RMS value of the current when the last compressor starts (FLA of the entire unit - FLA of the largest compressor + LRA of the largest compressor)
- (4) Maximum effective RMS value of the current when the last compressor starts (FLA of the entire unit - FLA of the largest compressor + 0.6 x LRA of the largest compressor)
- (5) These values are determined for cables with operating temperature of 40°C, EPR insulation and a line with a maximum length of 50m. The line section must be determined by a qualified technician based on the protection devices, the length of the line, the type of cable used and the type of installation.
- (6) The correct line protection part must be determined by a qualified technician based on the length of the line, the type of cable used and the type of installation.

BETA REV RFE SLN

			3.2	4.2	5.2	6.2	7.2	8.2	9.2
General electrical specifications									
Max. absorbed power (FLI)	(1)	kW	22,9	26,0	28,9	34,7	38,0	42,0	46,4
Max. absorbed current (FLA)	(1)	A	41,3	50,9	52,1	63,3	75,3	80,3	84,5
Rated current (Inom)	(2)	A	-	-	-	-	-	-	-
cosφ standard unit	(2)		-	-	-	-	-	-	-
Nominal current with power factor correction (Inom)	(2)	A	-	-	-	-	-	-	-
cosφ unit with power factor correction	(2)		-	-	-	-	-	-	-
Max. inrush current (MIC)	(3)	A	126	141	170	156	184	220	287
Maximum inrush current with soft-starter (MIC)	(4)	A	86	97	114	109	128	151	191
Power supply		V/ph/Hz	400/3~/50	400/3~/50	400/3~/50	400/3~/50	400/3~/50	400/3~/50	400/3~/50
Power supply for auxiliary circuits		V/ph/Hz	230- 24/1~/50	230- 24/1~/50	230- 24/1~/50	230- 24/1~/50	230- 24/1~/50	230- 24/1~/50	230- 24/1~/50
Suggested line section	(5)	mm ²	-	-	-	-	-	-	-
Suggested line protection	(6)		-	-	-	-	-	-	-
Electrical specifications for fans									
Rated power of fan standard		n° x kW	2 x 3,1	2 x 3,1	2 x 3,1	3 x 3,1	3 x 3,1	3 x 3,7	3 x 3,7
Rated current of fan standard		n° x A	2 x 4,8	2 x 4,8	2 x 4,8	3 x 4,8	3 x 4,8	3 x 5,7	3 x 5,7

- (1) Data regarding the unit without accessories working in maximum power absorption conditions
- (2) Datum related to the unit without accessories working in standard conditions (A35°C; W12/7°C)
- (3) Maximum effective RMS value of the current when the last compressor starts (FLA of the entire unit - FLA of the largest compressor + LRA of the largest compressor)
- (4) Maximum effective RMS value of the current when the last compressor starts (FLA of the entire unit - FLA of the largest compressor + 0.6 x LRA of the largest compressor)
- (5) These values are determined for cables with operating temperature of 40°C, EPR insulation and a line with a maximum length of 50m. The line section must be determined by a qualified technician based on the protection devices, the length of the line, the type of cable used and the type of installation.
- (6) The correct line protection part must be determined by a qualified technician based on the length of the line, the type of cable used and the type of installation.

BETA REV RFE SLN

			10.2	12.2	13.2	15.2	16.2	14.4	16.4
General electrical specifications									
Max. absorbed power (FLI)	(1)	kW	50,7	56,1	66,9	76,3	85,7	72,1	81,3
Max. absorbed current (FLA)	(1)	A	88,7	99,1	117,7	134,5	151,3	144,5	156,5
Rated current (Inom)	(2)	A	-	-	-	-	-	-	-
cosφ standard unit	(2)		-	-	-	-	-	-	-
Nominal current with power factor correction (Inom)	(2)	A	-	-	-	-	-	-	-
cosφ unit with power factor correction	(2)		-	-	-	-	-	-	-
Max. inrush current (MIC)	(3)	A	291	338	357	379	396	254	297
Maximum inrush current with soft-starter (MIC)	(4)	A	195	223	242	255	272	198	227
Power supply		V/ph/Hz	400/3~/50	400/3~/50	400/3~/50	400/3~/50	400/3~/50	400/3~/50	400/3~/50
Power supply for auxiliary circuits		V/ph/Hz	230- 24/1~/50	230- 24/1~/50	230- 24/1~/50	230- 24/1~/50	230- 24/1~/50	230- 24/1~/50	230- 24/1~/50
Suggested line section	(5)	mm ²	-	-	-	-	-	-	-
Suggested line protection	(6)		-	-	-	-	-	-	-
Electrical specifications for fans									
Rated power of fan standard		n° x kW	3 x 3,7	3 x 3,7	5 x 3,7	5 x 3,7	5 x 3,7	5 x 3,7	5 x 3,7
Rated current of fan standard		n° x A	3 x 5,7	3 x 5,7	5 x 5,7	5 x 5,7	5 x 5,7	5 x 5,7	5 x 5,7

- (1) Data regarding the unit without accessories working in maximum power absorption conditions
- (2) Datum related to the unit without accessories working in standard conditions (A35°C; W12/7°C)
- (3) Maximum effective RMS value of the current when the last compressor starts (FLA of the entire unit - FLA of the largest compressor + LRA of the largest compressor)
- (4) Maximum effective RMS value of the current when the last compressor starts (FLA of the entire unit - FLA of the largest compressor + 0.6 x LRA of the largest compressor)
- (5) These values are determined for cables with operating temperature of 40°C, EPR insulation and a line with a maximum length of 50m. The line section must be determined by a qualified technician based on the protection devices, the length of the line, the type of cable used and the type of installation.
- (6) The correct line protection part must be determined by a qualified technician based on the length of the line, the type of cable used and the type of installation.

HYDRAULIC MODULES

BETA REV RFE

			3.2	4.2	5.2	6.2	7.2	8.2	9.2	10.2
Volume of the expansion vessel		l	5	5	5	18	18	18	18	18
Volume of the buffer tank		l	165	165	165	200	200	450	450	450
Standard pumps										
Pump model 1P, 2P			P2	P2	P3	P4	P4	P5	P7	P7
Available head 1P	(1)	kPa	145	135	162	133	148	168	177	165
Available head 2P	(1)	kPa	137	125	149	117	128	136	162	147
Oversize pumps										
Pump model 1PM, 2PM			P6	P6	P6	P6	P6	P8	P8	P8
Available head 1PM	(1)	kPa	255	237	233	218	232	322	320	298
Available head 2PM	(1)	kPa	247	227	221	202	212	291	305	280
Pumps for glycol										
Pump model 1PG, 2PG			P15	P15	P16	P16	P16	P17	P17	P18
Available head 1PG	(1)	kPa	120	124	168	150	174	153	153	158
Available head 2PG	(1)	kPa	105	105	143	138	158	146	143	146

(1) External air temperature 35°C, user-side heat exchanger water inlet/outlet temperature 12/7°C. Values in accordance with EN 14511.

BETA REV RFE

			12.2	13.2	15.2	16.2	14.4	16.4	18.4	20.4	24.4
Volume of the expansion vessel		l	18	18	18	18	18	18	18	18	18
Volume of the buffer tank		l	450	450	390	390	390	390	700	700	700
Standard pumps											
Pump model 1P, 2P			P9	P9	P9	P10	P9	P10	P10	P10	P13
Available head 1P	(1)	kPa	172	160	157	184	170	194	176	153	218
Available head 2P	(1)	kPa	149	133	120	140	138	153	156	129	188
Oversize pumps											
Pump model 1PM, 2PM			P11	P11	P11	P11	P11	P12	P12	P12	P14
Available head 1PM	(1)	kPa	295	283	279	334	292	344	324	300	281
Available head 2PM	(1)	kPa	271	256	242	290	260	303	304	276	250
Pumps for glycol											
Pump model 1PG, 2PG			P18	P19	P19	P19	P18	P19	P19	P20	P20
Available head 1PG	(1)	kPa	146	175	169	148	142	159	126	192	171
Available head 2PG	(1)	kPa	132	157	157	133	131	145	118	182	159

(1) External air temperature 35°C, user-side heat exchanger water inlet/outlet temperature 12/7°C. Values in accordance with EN 14511.

BETA REV RFE HE

			3.2	4.2	5.2	6.2	7.2	8.2	9.2
Volume of the expansion vessel		l	5	5	5	18	18	18	18
Volume of the buffer tank		l	165	165	165	200	200	450	450
Standard pumps									
Pump model 1P, 2P			P2	P2	P4	P4	P4	P5	P7
Available head 1P	(1)	kPa	145,07	127,57	146	141,37	135,92	158,99	158,95
Available head 2P	(1)	kPa	136,07	115,92	131,09	120,09	126,04	145,35	141,75
Oversize pumps									
Pump model 1PM, 2PM			P6	P6	P6	P6	P6	P8	P8
Available head 1PM	(1)	kPa	246,75	243,78	233,76	225,58	220,13	310,71	294,95
Available head 2PM	(1)	kPa	237,75	232,13	218,85	204,29	210,24	297,07	277,75
Pumps for glycol									
Pump model 1PG, 2PG			P15	P15	P16	P16	P16	P17	P17
Available head 1PG	(1)	kPa	142,14	141,1	175,54	171,34	152,77	129,6	125,54
Available head 2PG	(1)	kPa	135,34	132,3	164,29	166,19	146,45	120,87	114,54

(1) External air temperature 35°C, user-side heat exchanger water inlet/outlet temperature 12/7°C. Values in accordance with EN 14511.

BETA REV RFE HE

			10.2	12.2	13.2	15.2	16.2	14.4	16.4
Volume of the expansion vessel		l	18	18	18	18	18	18	18
Volume of the buffer tank		l	390	390	450	390	390	390	390
Standard pumps									
Pump model 1P, 2P			P7	P9	P9	P9	P10	P9	P10
Available head 1P	(1)	kPa	142,83	158,95	159,95	140,57	174,48	155,99	174,89
Available head 2P	(1)	kPa	120,75	132,22	147,75	125,55	155,97	142,82	158,07
Oversize pumps									
Pump model 1PM, 2PM			P8	P11	P11	P11	P12	P11	P12
Available head 1PM	(1)	kPa	263,69	281,21	281,91	262,74	323,17	277,99	323,96
Available head 2PM	(1)	kPa	241,61	254,49	269,71	247,72	304,66	264,82	307,14
Pumps for glycol									
Pump model 1PG, 2PG			P18	P18	P19	P19	P19	P18	P19
Available head 1PG	(1)	kPa	123,77	121,4	165,25	138,06	125,64	112,31	120,59
Available head 2PG	(1)	kPa	116,35	112,42	160,16	131,78	117,91	106,8	113,56

(1) External air temperature 35°C, user-side heat exchanger water inlet/outlet temperature 12/7°C. Values in accordance with EN 14511.

BETA REV RFE SLN

			3.2	4.2	5.2	6.2	7.2	8.2	9.2
Volume of the expansion vessel		l	5	5	5	18	18	18	18
Volume of the buffer tank		l	165	165	165	200	200	450	450
Standard pumps									
Pump model 1P, 2P			P2	P2	P4	P4	P4	P5	P7
Available head 1P	(1)	kPa	145	128	146	141	136	159	159
Available head 2P	(1)	kPa	136	116	131	120	126	145	142
Oversize pumps									
Pump model 1PM, 2PM			P6	P6	P6	P6	P6	P8	P8
Available head 1PM	(1)	kPa	247	244	234	226	220	311	295
Available head 2PM	(1)	kPa	238	232	219	204	210	297	278
Pumps for glycol									
Pump model 1PG, 2PG			P15	P15	P16	P16	P16	P17	P17
Available head 1PG	(1)	kPa	142	141	176	171	153	130	126
Available head 2PG	(1)	kPa	135	132	164	166	146	121	115

(1) External air temperature 35°C, user-side heat exchanger water inlet/outlet temperature 12/7°C. Values in accordance with EN 14511.

BETA REV RFE SLN

			10.2	12.2	13.2	15.2	16.2	14.4	16.4
Volume of the expansion vessel		l	18	18	18	18	18	18	18
Volume of the buffer tank		l	390	390	450	390	390	390	390
Standard pumps									
Pump model 1P, 2P			P7	P9	P9	P9	P10	P9	P10
Available head 1P	(1)	kPa	143	159	160	141	174	156	175
Available head 2P	(1)	kPa	121	132	148	126	156	143	158
Oversize pumps									
Pump model 1PM, 2PM			P8	P11	P11	P11	P12	P11	P12
Available head 1PM	(1)	kPa	264	281	282	263	323	278	324
Available head 2PM	(1)	kPa	242	254	270	248	305	265	307
Pumps for glycol									
Pump model 1PG, 2PG			P18	P18	P19	P19	P19	P18	P19
Available head 1PG	(1)	kPa	124	121	165	138	126	112	121
Available head 2PG	(1)	kPa	116	112	160	132	118	107	114

(1) External air temperature 35°C, user-side heat exchanger water inlet/outlet temperature 12/7°C. Values in accordance with EN 14511.

PUMP DATA

Model	Rated power	Rated current	Qmin	Qmax
	kW	A	m ³ /h	m ³ /h
P1	1,1	2,7	3	9
P2	0,9	2,1	3,6	9,6
P3	0,9	2,4	3,6	9,6
P4	1,1	2,5	7	18
P5	1,5	3,2	7	18
P6	1,9	4,2	7	18
P7	1,9	4,5	12	31,2
P8	3	6,1	6	20
P9	2,2	4,5	12	42
P10	3	6,1	12	42
P11	4	8,7	12	42
P12	5,5	10,4	12	42
P13	5,5	10,4	24	72
P14	7,5	13,7	24	72
P15	1,5	3,2	7	18
P16	1,9	4,2	7	18
P17	3	5,9	12	31,2
P18	3	6,1	12	42
P19	4	8,7	12	42
P20	7,5	13,7	24	72
P21	0,6	1,6	3,6	9,6
P22	0,8	1,9	7	18
P23	1,5	3,4	12	28,8
P24	1,5	3,2	12	42
P25	3	6,1	24	72

USER-SIDE EXCHANGER FLOW RATE FIELDS

The units are sized and optimized for the following nominal conditions: external air 35°C, inlet/outlet of the user-side heat exchanger 12/7°C.

The units can work at design conditions different from nominal conditions, provided that:

- the design condition falls within the operating limits specified below
- the unit is equipped with all the accessories necessary for operation (e.g. brine kit, fan speed adjuster)
- the flow rate at design conditions (that is, of the specific application) must always come within the allowed flow rate ranges specified below. If the design conditions require a water flow rate that does not come within the allowed operating range, you must contact our sales department that will identify the most suitable solution for the specific application.

BETA REV RFE

	Qmin	Qmax
	m3/h	m3/h
3.2	3,49	10,48
4.2	3,91	11,74
5.2	4,58	13,73
6.2	5,16	15,48
7.2	5,76	17,27
8.2	6,99	20,97
9.2	8,01	24,04
10.2	8,8	26,4
12.2	10,03	30,1
13.2	10,81	32,43
15.2	12,63	37,88
16.2	13,74	41,23
14.4	11,8	35,39
16.4	13,24	39,71
18.4	16,33	48,99
20.4	17,93	53,79
24.4	20,13	60,39

BETA REV RFE HE

	Qmin	Qmax
	m3/h	m3/h
3.2	3,66	10,99
4.2	4,25	12,74
5.2	5,03	15,1
6.2	5,47	16,41
7.2	6,24	18,71
8.2	7,54	22,61
9.2	8,7	26,1
10.2	9,59	28,77
12.2	11,04	33,12
13.2	12,01	36,02
15.2	13,71	41,14
16.2	15,51	46,52
14.4	12,48	37,43
16.4	14,79	44,36

BETA REV RFE SLN

	Qmin	Qmax
	m3/h	m3/h
3.2	3,52	10,55
4.2	3,98	11,94
5.2	4,53	13,58
6.2	5,38	16,14
7.2	6,11	18,34
8.2	7,2	21,59
9.2	8,15	24,46
10.2	9,19	27,57
12.2	10,13	30,4
13.2	11,8	35,4
15.2	13,28	39,84
16.2	14,67	44
14.4	12,22	36,65
16.4	14	42

OPERATING LIMITS

BETA REV RFE

COOLING

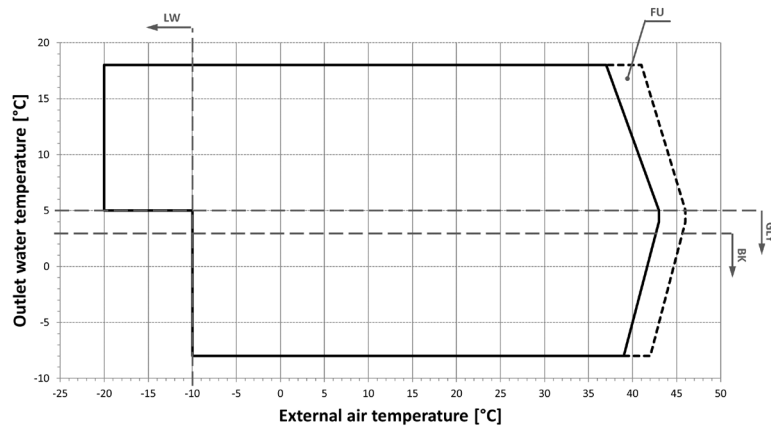

TOTAL RECOVERY

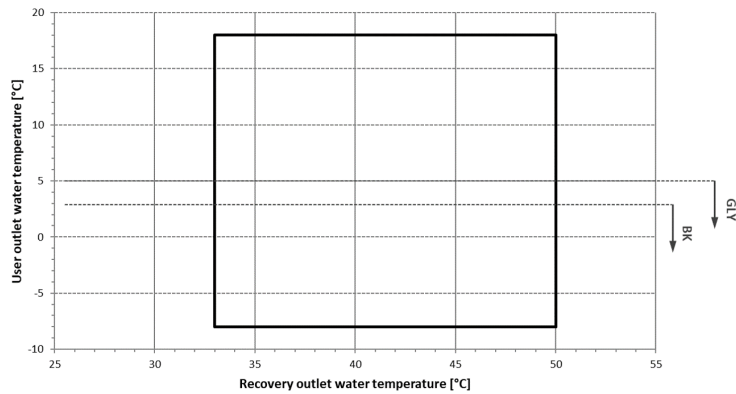

Ta: external air temperature

LWTu: water outlet temperature from the user-side heat exchanger

LWTr: water outlet temperature from the recovery exchanger

LW: in the indicated area, the unit can work only where there is no wind

FU: in the indicated area, the control could actuate a forced capacity reduction of the compressors so as to prevent tripping of the safety devices

BK: For LWTu lower or equal to +3°C, it is mandatory to fit the "Brine Kit" accessory

For LWTu below +5°C, it is compulsory to use suitable percentages of antifreeze additives (glycols) to prevent ice formation in the exchanger.

The inlet and outlet temperatures of the user-side exchanger must be given on ordering to allow correct setting of the alarm parameters and verification of the sizing of the expansion valve.

The cooling set point can then be changed by the customer in an interval that, compared to the set point given on ordering, ranges from -1K up to the maximum temperature allowed by the above-stated operating limits.

The unit will be optimized to work at the set point temperatures given on ordering. For different set points, the cooling capacity provided and the level of efficiency of the machine could decrease and move away from these conditions.

HEATING

For models Beta Rev RFE 3.2, 4.2, 5.2, 6.2, 7.2, 8.2, 14.4, 16.4

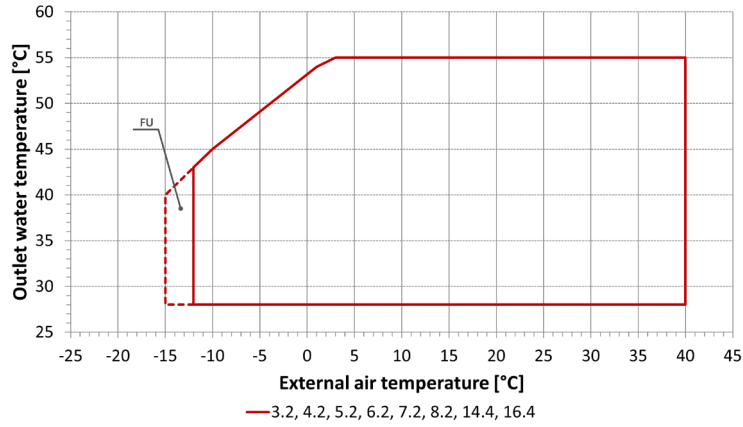

For models Beta Rev RFE 9.2, 10.2, 16.2, 18.4, 20.4

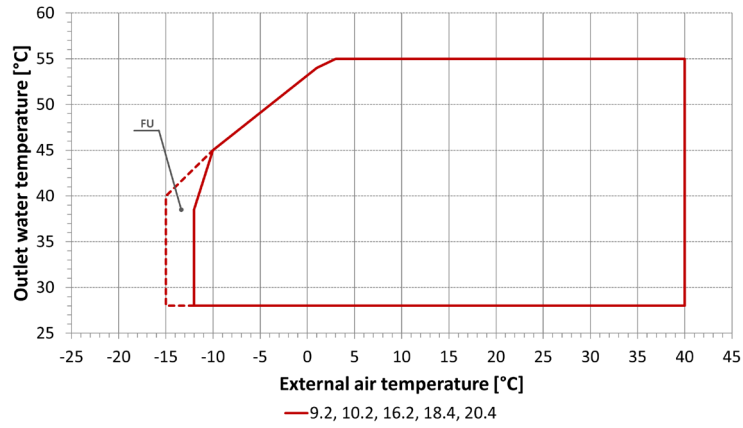

For models Beta Rev RFE 12.2, 13.2, 15.2, 24.4

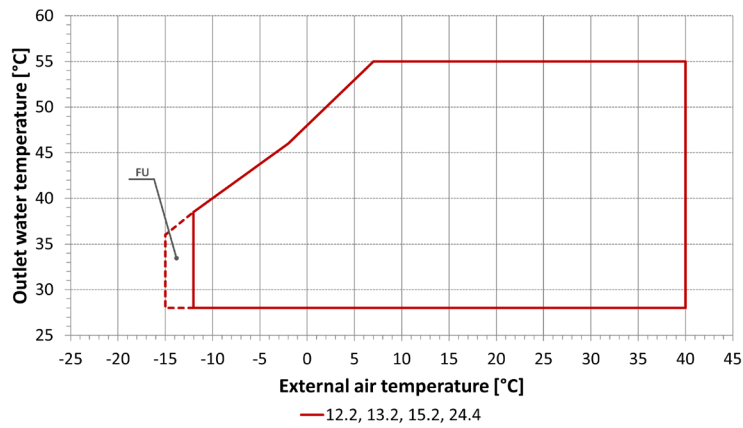

BETA REV RFE HE - RFE SLN

COOLING

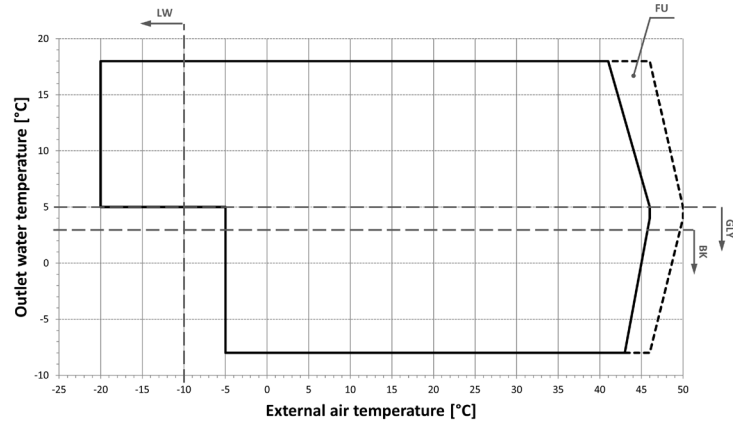

TOTAL RECOVERY

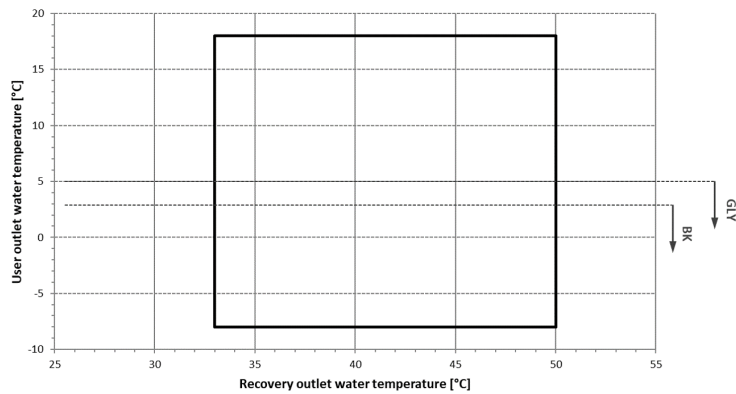

Ta: external air temperature

LWTu: water outlet temperature from the user-side heat exchanger

LWTr: water outlet temperature from the recovery exchanger

LW: in the indicated area, the unit can work only where there is no wind

FU: in the indicated area, the control could actuate a forced capacity reduction of the compressors so as to prevent tripping of the safety devices

BK: For LWTu lower or equal to +3°C, it is mandatory to fit the "Brine Kit" accessory

For LWTu below +5°C, it is compulsory to use suitable percentages of antifreeze additives (glycols) to prevent ice formation in the exchanger.

The inlet and outlet temperatures of the user-side exchanger must be given on ordering to allow correct setting of the alarm parameters and verification of the sizing of the expansion valve.

The cooling set point can then be changed by the customer in an interval that, compared to the set point given on ordering, ranges from -1K up to the maximum temperature allowed by the above-stated operating limits.

The unit will be optimized to work at the set point temperatures given on ordering. For different set points, the cooling capacity provided and the level of efficiency of the machine could decrease and move away from these conditions.

BETA REV RFE SLN

HEATING

For models Beta Rev RFE SLN 3.2, 4.2, 5.2, 6.2, 7.2, 8.2, 14.4, 16.4

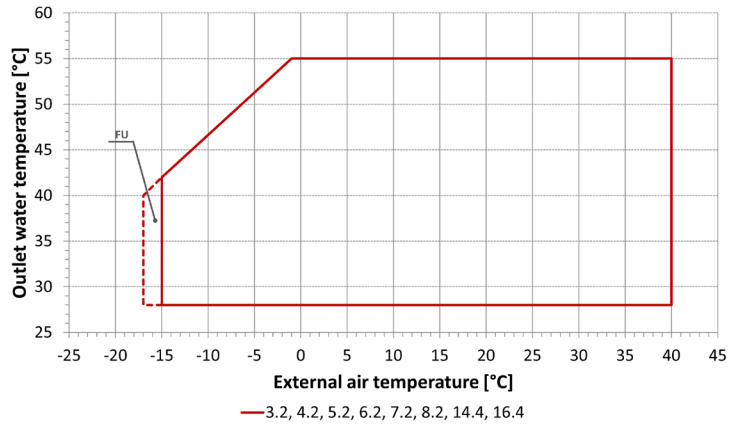

For models Beta Rev RFE SLN 9.2, 10.2, 16.2

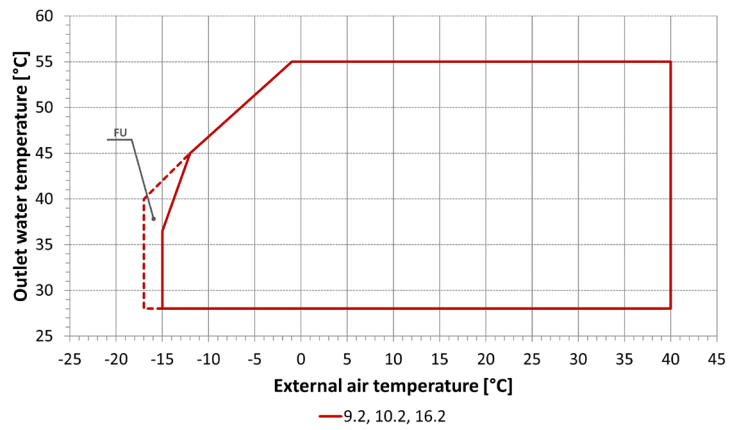

For models Beta Rev RFE SLN 12.2, 13.2, 15.2

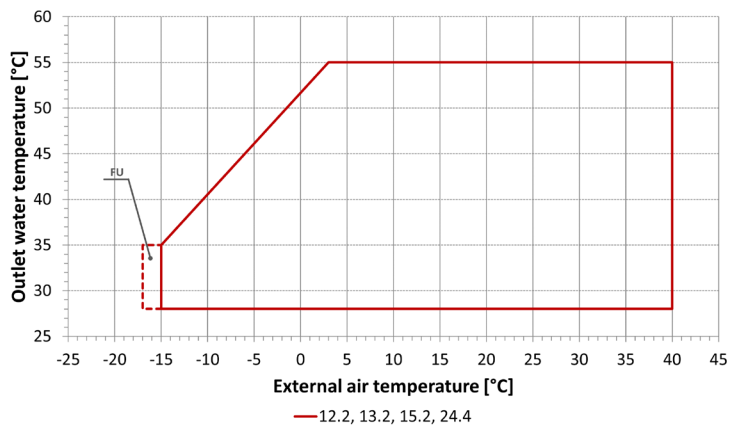

NOISE LEVELS

BETA REV RFE

	Octave bands [dB]																Total [dB(A)]	
	63 Hz		125 Hz		250 Hz		500 Hz		1000 Hz		2000 Hz		4000 Hz		8000 Hz		Lw_tot	Lp_tot
	Lw	Lp	Lw	Lp	Lw	Lp	Lw	Lp	Lw	Lp	Lw	Lp	Lw	Lp	Lw	Lp		
3.2	77	61	84	68	83	67	84	68	84	67	81	64	78	62	81	65	89	72
4.2	78	61	84	68	83	67	84	68	84	67	81	65	78	62	81	65	89	72
5.2	77	61	84	68	83	67	84	68	84	67	81	64	78	62	81	65	89	72
6.2	78	61	84	67	83	66	84	67	84	67	81	64	78	61	81	64	89	72
7.2	78	61	84	67	83	66	84	67	84	67	81	64	79	62	81	64	89	72
8.2	79	61	86	68	85	67	86	68	86	68	83	65	80	62	83	65	91	73
9.2	80	62	86	68	86	68	86	68	86	68	85	67	80	62	83	65	91	73
10.2	81	63	86	68	85	67	86	68	86	68	85	67	80	62	82	64	91	73
12.2	83	65	87	69	87	69	88	70	88	70	89	71	83	65	74	56	94	76
13.2	83	65	87	69	87	69	88	70	89	71	90	72	83	65	75	57	94	76
15.2	83	65	87	68	87	68	88	70	89	70	90	71	83	65	74	56	94	76
16.2	83	65	87	68	87	68	88	70	89	70	90	71	83	65	74	56	94	76
14.4	83	65	87	68	86	68	88	69	88	69	89	70	82	64	74	55	93	75
16.4	83	64	87	68	86	68	88	69	88	69	89	70	83	64	74	55	93	75
18.4	86	67	89	70	89	70	90	71	90	71	91	72	85	66	75	56	96	77
20.4	87	68	90	71	90	71	91	72	91	72	93	74	86	67	76	57	97	78
24.4	87	68	90	71	91	72	92	73	92	73	94	75	87	68	78	59	98	79

The acoustic data are related to standard conditions (source on a reflective surface in free field) in referable and reproducible operating conditions. The environment and the installation conditions, as well as the operating modes, can alter the sound emissions. All data with the exception of Lw_tot are provided for illustrative purposes only and can not be used for forecasting purposes or for the verification of binding limits.

Reference conditions: external air temperature 35°C; water input/output temperature from/to heat exchanger and user 12-7°C; unit operating at rated capacity, without any accessory

Lw: Values taken by measurements made in accordance with standard ISO 3744 and the Eurovent certification programme where applicable. Lw_tot is the only binding value.

Lp: Values calculated starting from noise power levels referred to a distance of 1 m from the unit; source installed on a reflective surface and in ideal free field conditions with directivity factor Q=2. No Lp value is binding.!

Noise data refer to the standard conditions illustrated above, in reference and reproducible operating conditions. All data, excluding Lw_tot, are provided for the sake of exemplification and must not therefore be used for forecasting purposes or for the verification of mandatory limits. With special reference to noise emissions, the Manufacturer takes liability for their conformity, limited to the declared Lw_tot value. Any and all other Manufacturer's liability for the impact of such emissions in relation to the location of the machine and other conditions related to machine installation is excluded. Any assessment concerning these conditions falls within the area of competence of the plant designer and/or the fitter.

NOISE LEVELS

BETA REV RFE /LN

	Octave bands [dB]																Total [dB(A)]	
	63 Hz		125 Hz		250 Hz		500 Hz		1000 Hz		2000 Hz		4000 Hz		8000 Hz		Lw_tot	Lp_tot
	Lw	Lp	Lw	Lp	Lw	Lp	Lw	Lp	Lw	Lp	Lw	Lp	Lw	Lp	Lw	Lp		
3.2	76	59	82	66	81	65	82	66	82	65	79	62	76	60	79	63	87	70
4.2	76	59	82	66	81	65	82	66	82	65	79	63	76	60	79	63	87	70
5.2	75	59	82	66	81	65	82	66	82	65	79	62	76	60	79	63	87	70
6.2	76	59	82	65	81	64	82	65	82	65	79	62	76	59	79	62	87	70
7.2	76	59	82	65	81	64	82	65	82	65	79	62	77	60	79	62	87	70
8.2	77	59	84	66	83	65	84	66	84	66	81	63	78	60	81	63	89	71
9.2	78	60	84	66	84	66	84	66	84	66	83	65	78	60	81	63	89	71
10.2	79	61	84	66	83	65	84	66	84	66	83	65	78	60	81	63	89	71
12.2	81	63	85	67	85	67	86	68	86	68	87	69	81	63	72	54	92	74
13.2	81	63	85	67	85	67	86	68	87	69	88	70	81	63	73	55	92	74
15.2	81	63	85	66	85	66	86	67	87	68	88	69	81	63	73	54	92	74
16.2	81	63	85	66	85	66	86	68	87	68	87	69	81	63	72	54	92	74
14.4	81	63	85	66	84	66	86	67	86	67	87	68	81	62	72	53	91	73
16.4	81	63	85	66	84	66	86	67	86	67	87	68	81	62	72	54	91	73
18.4	84	65	87	68	87	68	88	69	88	69	89	70	83	64	74	55	94	75
20.4	85	66	88	69	88	69	89	70	89	70	91	72	84	65	74	55	95	76
24.4	85	66	88	69	89	70	90	71	90	71	92	73	85	66	76	57	96	77

The acoustic data are related to standard conditions (source on a reflective surface in free field) in referable and reproducible operating conditions. The environment and the installation conditions, as well as the operating modes, can alter the sound emissions. All data with the exception of Lw_tot are provided for illustrative purposes only and can not be used for forecasting purposes or for the verification of binding limits.

Reference conditions: external air temperature 35°C; water input/output temperature from/to heat exchanger and user 12-7°C; unit operating at rated capacity, without any accessory

Lw: Values taken by measurements made in accordance with standard ISO 3744 and the Eurovent certification programme where applicable. Lw_tot is the only binding value.

Lp: Values calculated starting from noise power levels referred to a distance of 1 m from the unit; source installed on a reflective surface and in ideal free field conditions with directivity factor Q=2. No Lp value is binding.!

Noise data refer to the standard conditions illustrated above, in reference and reproducible operating conditions. All data, excluding Lw_tot, are provided for the sake of exemplification and must not therefore be used for forecasting purposes or for the verification of mandatory limits. With special reference to noise emissions, the Manufacturer takes liability for their conformity, limited to the declared Lw_tot value. Any and all other Manufacturer's liability for the impact of such emissions in relation to the location of the machine and other conditions related to machine installation is excluded. Any assessment concerning these conditions falls within the area of competence of the plant designer and/or the fitter.

BETA REV RFE HE

	Octave bands [dB]																Total [dB(A)]	
	63 Hz		125 Hz		250 Hz		500 Hz		1000 Hz		2000 Hz		4000 Hz		8000 Hz		Lw_tot	Lp_tot
	Lw	Lp	Lw	Lp	Lw	Lp	Lw	Lp	Lw	Lp	Lw	Lp	Lw	Lp	Lw	Lp		
3.2	78	61	85	68	84	67	85	68	84	67	81	64	78	61	82	65	89	72
4.2	78	61	85	68	84	67	84	67	84	67	81	64	78	61	81	64	89	72
5.2	78	61	85	68	84	67	85	68	84	67	81	64	78	61	81	64	89	72
6.2	78	60	85	67	84	66	84	66	84	66	81	63	78	60	82	64	89	71
7.2	78	60	85	67	84	66	84	66	84	66	81	63	79	61	82	64	89	71
8.2	82	64	85	67	85	67	86	68	87	69	87	69	81	63	72	54	92	74
9.2	82	64	85	67	85	67	86	68	86	68	87	69	81	63	72	54	92	74
10.2	82	64	85	67	85	67	86	68	86	68	88	69	81	62	71	53	92	74
12.2	83	65	87	68	87	68	88	69	88	70	90	71	83	64	74	55	94	76
13.2	84	65	88	69	88	69	89	70	90	71	91	72	84	65	75	56	95	76
15.2	84	65	88	69	88	69	89	70	90	71	90	71	84	65	75	56	95	76
16.2	84	65	88	69	88	69	89	70	90	71	90	71	84	65	75	56	95	76
14.4	85	66	88	69	88	69	89	70	90	71	90	71	84	65	75	56	95	76
16.4	85	66	88	69	88	69	89	70	89	70	90	71	84	65	75	56	95	76

The acoustic data are related to standard conditions (source on a reflective surface in free field) in referable and reproducible operating conditions. The environment and the installation conditions, as well as the operating modes, can alter the sound emissions. All data with the exception of Lw_tot are provided for illustrative purposes only and can not be used for forecasting purposes or for the verification of binding limits.

Reference conditions: external air temperature 35°C; water input/output temperature from/to heat exchanger and user 12-7°C; unit operating at rated capacity, without any accessory

Lw: Values taken by measurements made in accordance with standard ISO 3744 and the Eurovent certification programme where applicable. Lw_tot is the only binding value.

Lp: Values calculated starting from noise power levels referred to a distance of 1 m from the unit; source installed on a reflective surface and in ideal free field conditions with directivity factor Q=2. No Lp value is binding.!

Noise data refer to the standard conditions illustrated above, in reference and reproducible operating conditions. All data, excluding Lw_tot, are provided for the sake of exemplification and must not therefore be used for forecasting purposes or for the verification of mandatory limits. With special reference to noise emissions, the Manufacturer takes liability for their conformity, limited to the declared Lw_tot value. Any and all other Manufacturer's liability for the impact of such emissions in relation to the location of the machine and other conditions related to machine installation is excluded. Any assessment concerning these conditions falls within the area of competence of the plant designer and/or the fitter.

BETA REV RFE /LN

	Octave bands [dB]																Total [dB(A)]	
	63 Hz		125 Hz		250 Hz		500 Hz		1000 Hz		2000 Hz		4000 Hz		8000 Hz		Lw_tot	Lp_tot
	Lw	Lp	Lw	Lp	Lw	Lp	Lw	Lp	Lw	Lp	Lw	Lp	Lw	Lp	Lw	Lp		
3.2	76	59	82	66	81	65	82	66	82	65	79	62	76	60	79	63	87	70
4.2	76	59	82	66	81	65	82	66	82	65	79	63	76	60	79	63	87	70
5.2	75	59	82	66	81	65	82	66	82	65	79	62	76	60	79	63	87	70
6.2	76	59	82	65	81	64	82	65	82	65	79	62	76	59	79	62	87	70
7.2	76	59	82	65	81	64	82	65	82	65	79	62	77	60	79	62	87	70
8.2	77	59	84	66	83	65	84	66	84	66	81	63	78	60	81	63	89	71
9.2	78	60	84	66	84	66	84	66	84	66	83	65	78	60	81	63	89	71
10.2	79	61	84	66	83	65	84	66	84	66	83	65	78	60	81	63	89	71
12.2	81	63	85	67	85	67	86	68	86	68	87	69	81	63	72	54	92	74
13.2	81	63	85	67	85	67	86	68	87	69	88	70	81	63	73	55	92	74
15.2	81	63	85	66	85	66	86	67	87	68	88	69	81	63	73	54	92	74
16.2	81	63	85	66	85	66	86	68	87	68	87	69	81	63	72	54	92	74
14.4	81	63	85	66	84	66	86	67	86	67	87	68	81	62	72	53	91	73
16.4	81	63	85	66	84	66	86	67	86	67	87	68	81	62	72	54	91	73
18.4	84	65	87	68	87	68	88	69	88	69	89	70	83	64	74	55	94	75
20.4	85	66	88	69	88	69	89	70	89	70	91	72	84	65	74	55	95	76
24.4	85	66	88	69	89	70	90	71	90	71	92	73	85	66	76	57	96	77

The acoustic data are related to standard conditions (source on a reflective surface in free field) in referable and reproducible operating conditions. The environment and the installation conditions, as well as the operating modes, can alter the sound emissions. All data with the exception of Lw_tot are provided for illustrative purposes only and can not be used for forecasting purposes or for the verification of binding limits.

Reference conditions: external air temperature 35°C; water input/output temperature from/to heat exchanger and user 12-7°C; unit operating at rated capacity, without any accessory

Lw: Values taken by measurements made in accordance with standard ISO 3744 and the Eurovent certification programme where applicable. Lw_tot is the only binding value.

Lp: Values calculated starting from noise power levels referred to a distance of 1 m from the unit; source installed on a reflective surface and in ideal free field conditions with directivity factor Q=2. No Lp value is binding.!

Noise data refer to the standard conditions illustrated above, in reference and reproducible operating conditions. All data, excluding Lw_tot, are provided for the sake of exemplification and must not therefore be used for forecasting purposes or for the verification of mandatory limits. With special reference to noise emissions, the Manufacturer takes liability for their conformity, limited to the declared Lw_tot value. Any and all other Manufacturer's liability for the impact of such emissions in relation to the location of the machine and other conditions related to machine installation is excluded. Any assessment concerning these conditions falls within the area of competence of the plant designer and/or the fitter.

BETA REV RFE SLN

	Octave bands [dB]																Total [dB(A)]	
	63 Hz		125 Hz		250 Hz		500 Hz		1000 Hz		2000 Hz		4000 Hz		8000 Hz		Lw_tot	Lp_tot
	Lw	Lp	Lw	Lp	Lw	Lp	Lw	Lp	Lw	Lp	Lw	Lp	Lw	Lp	Lw	Lp		
3.2	73	56	79	62	79	62	82	65	80	63	77	60	76	59	74	57	85	68
4.2	73	56	78	61	78	61	81	64	80	63	78	61	75	58	74	57	85	68
5.2	72	55	78	61	78	61	81	64	80	63	78	61	75	58	74	57	85	68
6.2	72	54	78	60	78	60	80	62	80	62	79	61	75	57	75	57	85	67
7.2	74	56	78	60	77	59	81	63	80	62	79	61	75	57	74	56	85	67
8.2	76	58	79	61	79	61	81	63	82	64	82	64	76	58	69	51	87	69
9.2	77	59	78	60	79	61	81	63	81	63	83	65	76	58	68	50	87	69
10.2	78	59	77	59	80	61	81	62	81	62	83	65	75	57	66	48	87	69
12.2	79	60	79	61	82	63	83	64	84	66	86	68	79	60	71	53	90	72
13.2	78	59	80	61	81	62	83	64	84	65	86	67	79	60	72	53	90	71
15.2	77	58	80	61	81	62	83	64	85	66	86	67	79	60	72	53	90	71
16.2	77	58	80	61	81	62	83	64	85	66	85	66	79	60	71	52	90	71
14.4	81	62	83	64	83	64	85	66	86	67	86	67	80	61	73	54	91	72
16.4	80	61	83	64	83	64	85	66	86	67	86	67	80	61	73	54	91	72

The acoustic data are related to standard conditions (source on a reflective surface in free field) in referable and reproducible operating conditions. The environment and the installation conditions, as well as the operating modes, can alter the sound emissions. All data with the exception of Lw_tot are provided for illustrative purposes only and can not be used for forecasting purposes or for the verification of binding limits.

Reference conditions: external air temperature 35°C; water input/output temperature from/to heat exchanger and user 12-7°C; unit operating at rated capacity, without any accessory

Lw: Values taken by measurements made in accordance with standard ISO 3744 and the Eurovent certification programme where applicable. Lw_tot is the only binding value.

Lp: Values calculated starting from noise power levels referred to a distance of 1 m from the unit; source installed on a reflective surface and in ideal free field conditions with directivity factor Q=2. No Lp value is binding.!

Noise data refer to the standard conditions illustrated above, in reference and reproducible operating conditions. All data, excluding Lw_tot, are provided for the sake of exemplification and must not therefore be used for forecasting purposes or for the verification of mandatory limits. With special reference to noise emissions, the Manufacturer takes liability for their conformity, limited to the declared Lw_tot value. Any and all other Manufacturer's liability for the impact of such emissions in relation to the location of the machine and other conditions related to machine installation is excluded. Any assessment concerning these conditions falls within the area of competence of the plant designer and/or the fitter.

INSTALLATION ADVICE

The units described in this document are, by nature, strongly affected by the characteristics of the system, the working conditions and the installation site.

Remember that the unit must be installed by a qualified and skilled technician, and in compliance with the national legislation in force in the destination country.

The installation must be done in such a way that it will be possible to carry out all routine and non-routine maintenance operations.

Before starting any work, you must carefully read the "Installation, operation and maintenance manual" of the machine and do the necessary safety checks to prevent any malfunctioning or hazards.

We give some advice below that will allow you to increase the efficiency and reliability of the unit and therefore of the system into which it is inserted.

Water characteristics

To preserve the life of the exchangers, the water is required to comply with some quality parameters and it is therefore necessary to make sure its values fall within the ranges indicated in the following table:

Total hardness	2,0 ÷ 6,0 °f 1,2 ÷ 3,4 °d
Langelier index	- 0,4 ÷ 0,4
pH	7,5 ÷ 8,5
Electrical conductivity	10÷500 µS/cm
Organic elements	-
Hydrogen carbonate (HCO₃⁻)	70 ÷ 300 ppm
Sulphates (SO₄²⁻)	< 50 ppm
Hydrogen carbonate / Sulphates (HCO₃⁻/SO₄²⁻)	> 1
Chlorides (Cl⁻)	< 50 ppm
Nitrates (NO₃⁻)	< 50 ppm
Hydrogen sulphide (H₂S)	< 0,05 ppm
Ammonia (NH₃)	< 0,05 ppm
Sulphites (SO₃⁻), free chlorine (Cl₂)	< 1 ppm
Carbon dioxide (CO₂)	< 5 ppm
Metal cations	< 0,2 ppm
Manganese ions (Mn⁺⁺)	< 0,2 ppm
Iron ions (Fe²⁺ , Fe³⁺)	< 0,2 ppm
Iron + Manganese	< 0,4 ppm
Phosphates (PO₄³⁻)	< 2 ppm
Oxygen	< 0,1 ppm

Installation of water filters on all the hydraulic circuits is obligatory.

The supply of the most suitable filters for the unit can be requested as accessory. In this case, the filters are supplied loose and must be installed by the customer following the instructions given in the installation, operation and maintenance manual.

Glycol mixtures

With temperatures below 5°C, it is mandatory to work with water and anti-freeze mixtures, and also change the safety devices (anti-freeze, etc.), which must be carried out by qualified authorised personnel or by the manufacturer.

Liquid outlet temperature or minimum ambient temperature	°C	0	-5	-10	-15	-20	-25	-30	-35	-40
Freezing point	°C	-5	-10	-15	-20	-25	-30	-35	-40	-45
Ethylene glycol	%	6	22	30	36	41	46	50	53	56
Propylene glycol	%	15	25	33	39	44	48	51	54	57

The quantity of antifreeze should be considered as % on weight

Minimum water content in the system

For correct operation of the unit, it is necessary to ensure a buffering on the system such as to comply with the minimum operating time considering the greater between the minimum OFF time and the minimum ON time. In short, these contribute to limiting the number of times the compressors are switched on per hour and to preventing undesired deviations from the set point of the delivered water temperature.

The following experimental formula allows the minimum water volume of the system to be calculated:

$$V_{min} = \frac{P_{tot} \cdot 1.000}{N} \cdot \frac{300}{\Delta T \cdot \rho \cdot c_p} + P_{tot} \cdot 0,25$$

where

V_{min} is the minimum water content of the system [l]

P_{tot} is the total cooling capacity of the machine [kW]

N: number of capacity reduction steps

ΔT : differential allowed on the water temperature. Unless otherwise specified, this value is considered to be 2.5K

ρ : density of the heat-carrying fluid. Unless otherwise specified, the density of water is considered

c_p : specific heat of the heat-carrying fluid. Unless otherwise specified, the specific heat of water is considered

Considering the use of water and grouping together some terms, the formula can be re-written as follows:

$$V_{min} = \frac{P_{tot}}{N} \cdot 17,2 + P_{tot} \cdot 0,25$$

N is equal to the number of compressors installed in the unit.

In case of installation in cold climates where the unit has to perform defrosting cycles, it is suggested to use higher water content than that calculated with previous formula; due to very high volumes needed to completely compensate the negative effect of defrost on produced water temperature, are usually accepted higher temperature deviations than typical values accapeted for cooling-only unit.

Larger amounts of water are in any case always preferable, because they allow a smaller number of starts and switch-offs of the compressors, less wear of them and an increase in the efficiency of the system as a consequence of a reduction in the number of transients.

It should also be pointed out that, for air-water units working in heat pump mode, the minimum amount of water must consider the need of the unit to carry out defrosting. Having an adequate buffering volume will allow prevention of too high drifts of the delivered water temperature at the end of the defrost cycle.

Installation site

To determine the best installation site for the unit and its orientation, you should pay attention to the following points:

- compliance with the clearance spaces indicated in the official dimensional drawing of the unit must be guaranteed so as to ensure accessibility for routine and non-routine maintenance operations
- you should consider the origin of the hydraulic pipes and their diameters because these affect the radiuses of curvature and therefore the spaces needed for installing them
- you should consider the position of the cable inlet on the electrical control panel of the unit as regards the origin of the power supply
- if the installation includes several units side by side, you should consider the position and dimensions of the manifolds of the user-side exchangers and of any recovery exchangers
- if the installation includes several units side by side, you should consider that the minimum distance between units is 3 metres
- you should avoid all obstructions that can limit air circulation to the source-side exchanger or that can cause recirculation between air supply and intake
- you should consider the orientation of the unit to limit, as far as possible, exposure of the source-side exchanger to solar radiation
- if the installation area is particularly windy, the orientation and positioning of the unit must be such as to avoid air recirculation on the coils. If necessary, we advise making windbreak barriers in order to prevent malfunctioning.

Once the best position for the unit has been identified, you must check that the support slab has the following characteristics:

- its dimensions must be proportionate to those of the unit: if possible, longer and wider than the unit by at least 30 cm and 15/20cm higher than the surrounding surface
- it must be able to bear at least 4 times the operating weight of the unit
- it must allow level installation of the unit: although the unit is installed on a horizontal base, make slopes in the support surface to convey rain water or defrost water to drains, wells or in any case to places where it cannot generate an accident hazard due to ice formation. All heat pump version units are equipped with discharge manifolds for the condensed water; these can be manifolded to facilitate condensate discharge.

The units are designed and built to reduce to a minimum the level of vibration transmitted to the ground, but it is in any case advisable to use rubber or spring anti-vibration mounts, which are available as accessory and should be requested when ordering.

The anti-vibration mounts must be fixed on before positioning the unit on the ground.

In the event of installation on roofs or intermediate floors, the pipes must be isolated from the walls and ceilings.

It is advisable to avoid installation in cramped places, to prevent reverberations, reflections, resonances and acoustic interactions with elements outside the unit.

It is essential that any work done to soundproof the unit does not affect its correct installation or correct operation and, in particular, does not reduce the air flow rate to the source-side exchanger.

Installations that require the use of treated coils

If the unit has to be installed in an environment with a particularly aggressive atmosphere, coils with special treatments are available as options.

- e-coated microchannel coils (accessory not available for HP units)
- coils with anti-corrosion treatment (accessory available only for HP units or with Cu/Al coil)

A description of the individual accessories is available in the "Description of accessories" section.

The type of coil treatment should be chosen with regard to the environment in which the unit is to be installed, through observation of other structures and machinery with exposed metal surfaces present in the destination environment.

The cross observation criterion is the most valid method of selection currently available without having to carry out preliminary tests or measurements with instruments. The identified reference environments are:

- coastal/marine
- industrial
- urban with a high housing density
- rural

Please note that in cases where different conditions co-exist, even for short periods, the choice must be suitable for preserving the exchanger in the harsher environmental conditions and not in conditions between the worst and best situation.

Particular attention must be given in cases where an environment that is not particularly aggressive becomes aggressive as a consequence of a concomitant cause, for example, the presence of a flue outlet or an extraction fan.

We strongly suggest choosing one of the treatment options if at least one of the points listed below is verified:

- there are obvious signs of corrosion of the exposed metal surfaces in the installation area
- the prevailing winds come from the sea towards the unit
- the environment is industrial with a significant concentration of pollutants
- the environment is urban with a high population density
- the environment is rural with the presence of organic discharges and effluents

In particular, for installations near the coast, the following instructions apply:

- **for installations between 1 and 20 km from the coast of units with microchannel coil, we strongly recommend using the accessory "E-coated microchannel coils"**
- **for installations between 1 and 20 km from the coast of reversible units or units with Cu/Al coils, is strongly recommended using the accessory "Coil treated with anti-corrosion paints"**
- **for distances within a kilometre of the coast, we strongly recommend using the accessory "Coil treated with anti-corrosion paints" for all units**

To protect the exchangers from corrosion and ensure optimal operation of the unit, we advise following the recommendations given in the user, installation and maintenance manual for cleaning the coils.

Swegon Operations s.r.l.

Via Valletta, 5 - 30010

Cantarana di Cona, (VE) Italy - T. +39 0426 921111 - F. +39 0426 302222

www.blueboxcooling.com - info@bluebox.it



Swegon Operations s.r.l. a socio unico - P.IVA 02481290282

Company directed and coordinated by Investment Latour (Sweden)