

DCC

Low velocity terminal for small air flows



QUICK FACTS

- Fixed radial spread pattern
- Pressure-raising insert
- Simple installation
- Cleanable
- Standard colour Black RAL 9005
 - 5 alternative standard colours
 - Other colours upon request

Technical description

Design

DCC is a complete, circular low velocity terminal. The lower section has a connection spigot with a rubber seal. The perforated outer casing can be removed from the lower section by unscrewing it from the bayonet mounting. Available in two versions, with or without the pressure-raising insert. The pressure-raising insert provides better control over the system and more uniform air distribution if several air diffusers are used.

Materials and surface treatment

The whole unit is made from galvanised sheet steel and painted in the colour selected when the order is placed. The standard version is painted.

- Standard colour:
 - Black semi-gloss, lustre 35, RAL 9005
- Alternative standard colours:
 - Silver gloss, lustre 80, RAL 9006
 - Grey aluminium gloss, lustre 80, RAL 9007
 - White semi-gloss, lustre 40, RAL 9010
 - White semi-gloss, lustre 40, RAL 9003/NCS S 0500-N
 - Grey semi-gloss, lustre 30, RAL 7037
- Non-painted finish and other colours available on request.

Special versions

In addition to the standard version, these displacement units are available in special dimensions, other shapes etc. Please contact your nearest sales representative for further information.

Planning

The low velocity terminal can either be mounted vertically or horizontally. See Figure 2.

Installation

The securing screw is first unscrewed, after which the outer casing can be rotated and removed from the lower section. The lower section is placed in the cut hole and fastened in place to the building framework using screws, see figure 2. Cut out dimension is shown in figure 4.

Commissioning

We recommend that the space underneath/behind the terminal should function as a pressure chamber. The feed duct to each pressure chamber is then equipped with a measurement and commissioning damper, type CRM or similar. See Figure 2.

Maintenance

The displacement unit can be cleaned when necessary using luke warm water with detergent added. See Figure 2.

Environment

The Declaration of construction materials is available at www.swegon.com

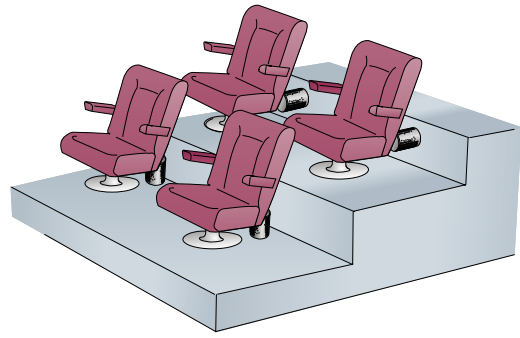

Figure 1. Principle DCC.

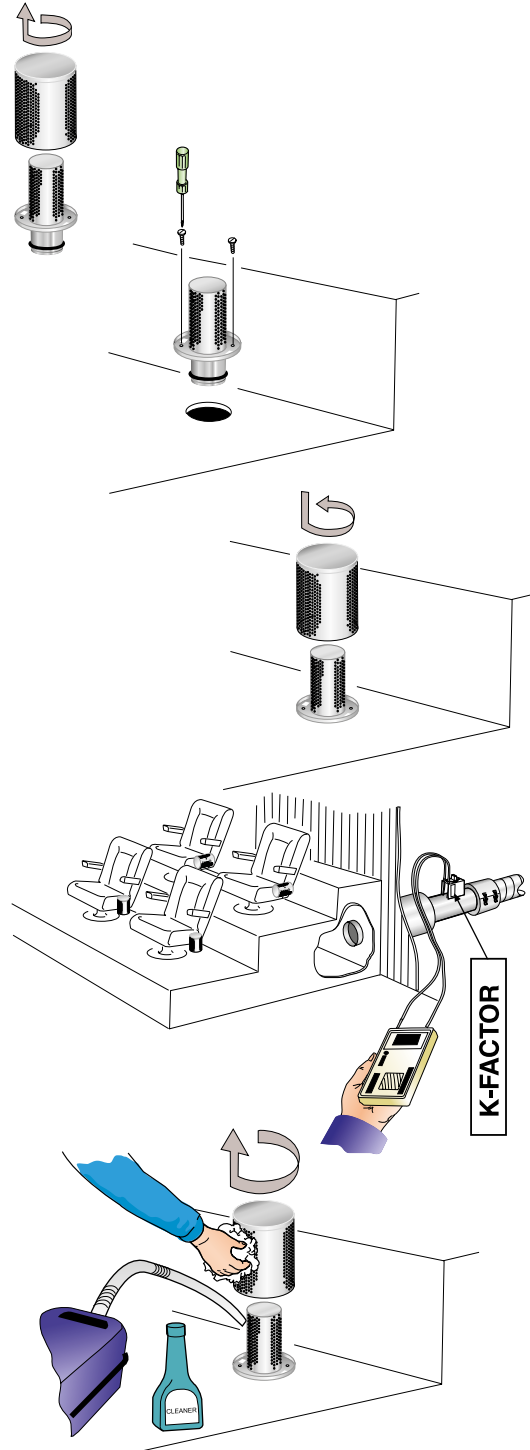

Figure 2. Installation. Commissioning. Maintenance.

Sizing

- Sound pressure level dB(A) applies to rooms with 10 m² equivalent sound absorption area.
- Sound attenuation (ΔL) below is shown in the octave band. Orifice attenuation is included in the values.
- The affected area a_{0,20} is measured at Δt -3° and refers to the maximum velocity irrespective of the distance from the floor.
- Δt is the difference between the room temperature at 1.2 m above the floor and the supply air temperature.
- Recommended maximum under temperature 6 K.
- To calculate the width of the airstream, air velocities in the zone of occupation or sound levels in rooms with other dimensions, please refer to our calculation programme ProAir web available for download at www.swegon.com

L_w = Sound power level

L_{p10A} = Sound pressure level dB (A)

K_{ok} = Correction for producing the L_w value in the octave band

L_w = L_{p10A} + K_{OK} gives the frequency divided octave band

Sound data

DCC

Sound power level L_w(dB)

Table K_{OK}

Size	Mid-frequency (octave band) Hz							
	63	125	250	500	1000	2000	4000	8000
DCC	63	125	250	500	1000	2000	4000	8000
100 -0	-3	-10	-5	0	2	-6	-18	-22
100-1	-4	-6	-4	-1	0	-4	-6	-6
Tol. ±	2	2	2	2	2	2	2	2

Sound attenuation ΔL (dB)

Table ΔL

Size	Mid-frequency (octave band) Hz							
	63	125	250	500	1000	2000	4000	8000
DCC	63	125	250	500	1000	2000	4000	8000
100 -0	16	12	8	3	1	0	0	0
100-1	20	16	11	7	2	0	0	0
Tol. ±	2	2	2	2	2	2	2	2

Engineering graphs

DCC – supply air

Air flow – Pressure drop – Sound level – Affected area

- The graphs illustrate data for a DCC unit installed in the open space below the seats, that functions as a plenum chamber.
- The affected area a_{0,20} is measured at Δt -3°.
- The graphs are not to be used for commissioning.
- The dB(C) value is normally 6-9 dB higher than the dB(A) value.

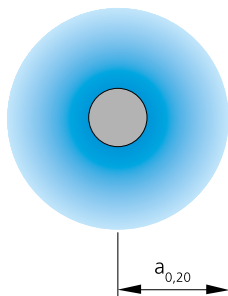
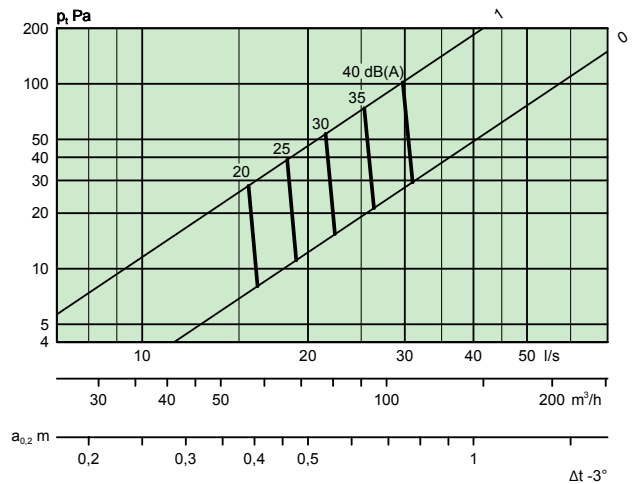

Figure 3. Affected area.

DCC 100



0 = Excluding the pressure insert
 1 = Including pressure insert

Dimensions and weights

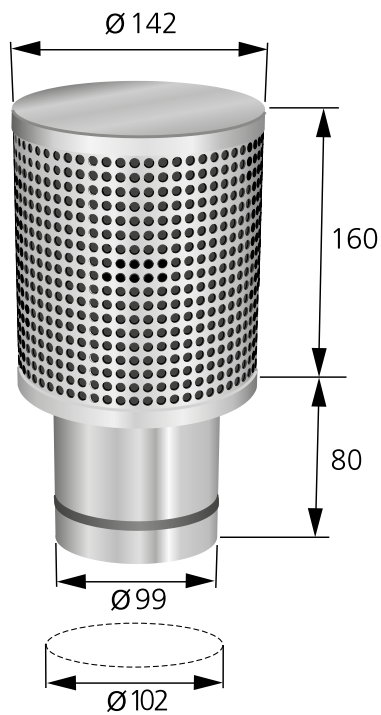

Figure 4. DCC. Unit of measure = mm. Weight: 1.2 kg. Cutout dimension = $\text{Ø}102$ mm.

Order key

Product

Circular low velocity terminal DCC b 100 -b

Version:

Size: 100

Variant

Excl. pressure insert: 0

Incl. pressure insert: 1

Specification example

Swegon's circular displacement unit of type DCC, having the following functions:

- Fixed spread pattern
- Non-fouling
- Cleanable
- Painted in matt black, RAL 9005

Size: DCCb 100 xx items