

COLIBRI Ceiling b

Installation – Commissioning – Maintenance 20210107

Accessories

Commissioning box:

ALS. The commissioning box is made of galvanized sheet steel and contains a removable adjustment damper, fixed measurement tappings and sound absorbing material*) with reinforced surface layer.

The ALS commissioning box is available with one or two differences in dimension between the inlet and the outlet and also a version for low installation where a low overall height is required. The ALS commissioning box is then supplied without outlet branch.

*) Fire resistance rated to B-s1,d0 in accordance with EN ISO 11925-2.

Frame:

SAR K. For aesthetic installation of a lowered diffuser.

Adapter:

ADAPTER, for adaptation to various variants and makes of systemized false ceilings: Ecophon, Gyproc, Dampa etc. Also used for adaptation to optional sizes of lay-in ceilings, for instance 625 x 625 or 675 x 675.

Installation

To dismantle the diffuser face, insert a thin object, for example a Quick Access card or the equivalent, in between the diffuser face and the diffuser backing box in order to release the springs. Move the card from the centre out towards the corner, see Figure 2.

The inlet spigot of the diffuser backing box can be secured to the connecting duct by means of self-tapping screws or a blind rivets. For flush-mounting in fixed ceiling constructions, secure the terminal by means of screws into place in the framework through either the sides or top of the diffuser backing box. The air diffuser and commissioning box in the version for low installation height must be centred and jointed together using the locking strip supplied. Secure the air diffuser in the correct position with self-tapping screws or pop rivets in the under side of the commissioning box. See Figure 4.

For mounting in modular suspended ceilings, it is advisable to select air diffusers with outer dimensions of 595 x 595 mm. Position these directly down in the T-bar framework, and then secure them to the duct system or to the commissioning box.

If an ALS commissioning box is used, it must be secured to the building structure by means of hangers or mounting brackets.

The distance between the commissioning box and the air diffuser can be increased by as much as 500 mm with an ordinary circular duct without having to lengthen the measuring tubes and damper commissioning cords. See Figure 3.

Commissioning

Commissioning should be carried out with the face plate mounted. Pull the measuring tube and damper adjusting cord out through the face plate. Connect a manometer to the right measuring tube. The red or blue tube is used for supply air depending on whether a one or two-step ALS commissioning box is used.

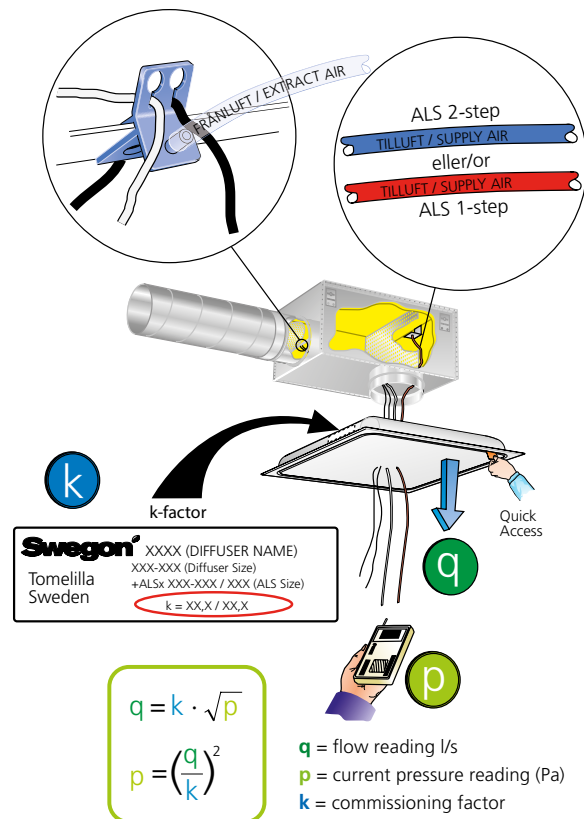

Figure 1. Commissioning.

For extract air, use the transparent tube only. The required commissioning pressure can be calculated by means of the K-factor of the air diffuser/register. Adjust the damper to the correct position and tie a commissioning knot on the damper cords to indicate the damper setting. See Figure 1.

Measurement accuracy and requirement on straight duct before the commissioning box, see Figure 3. The requirements of straight duct depends on the type of disturbance before the commissioning box. Figure 3 shows a bend, a dimensional change and a T-piece. Other types of disturbances requires at least 2xD straight (D = connection dimension) for measurement accuracy of $\pm 10\%$ of the flow.

The K-factor is specified on the product identification plate and also in the relevant commissioning instructions available at www.swegon.com.

Maintenance

The air diffuser can be cleaned, if necessary, using lukewarm water with dishwashing detergent added or by vacuum cleaning using a brush nozzle. The duct system can be reached for cleaning after opening the diffuser face. If a type ALS commissioning box is used, swing the diffuser face to the side on its hinges so that you then can grip the handle of the tubular damper casing and rotate it out of its holder. See Figure 5.

Installation

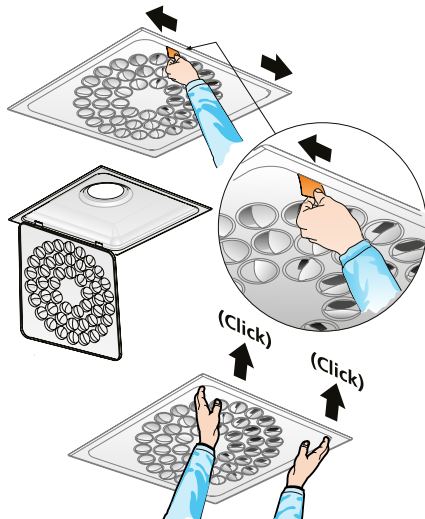

Figure 2. Quick Access, dismantling of the front.

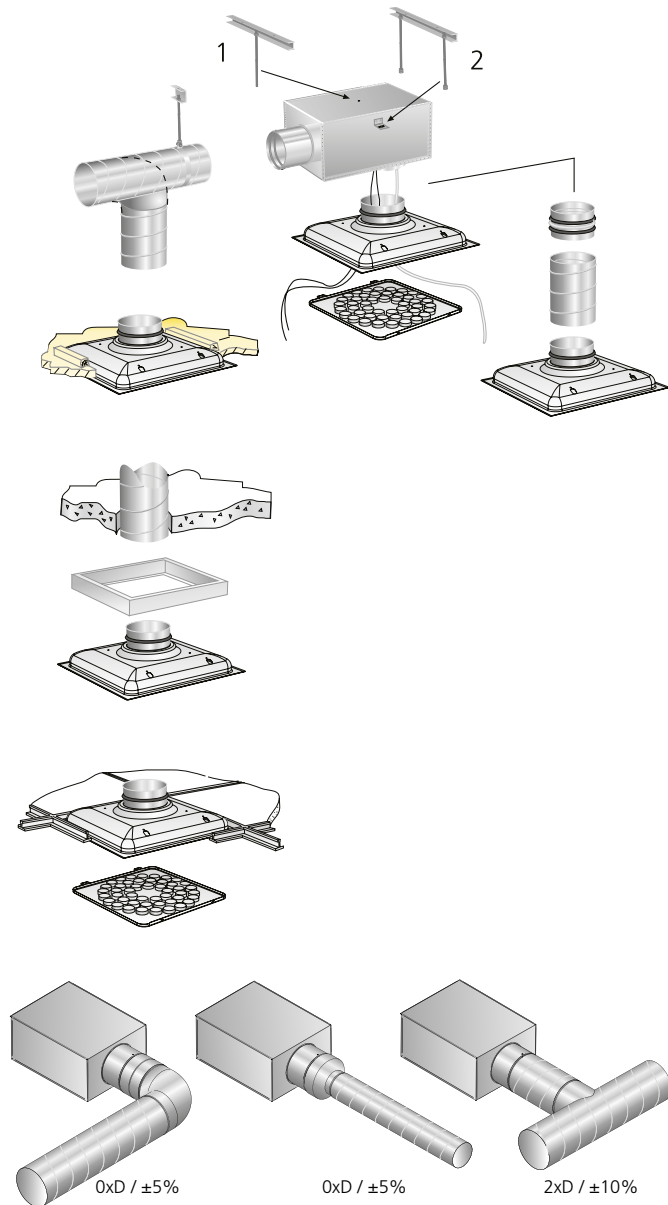

Figure 3. Installation alternatives.

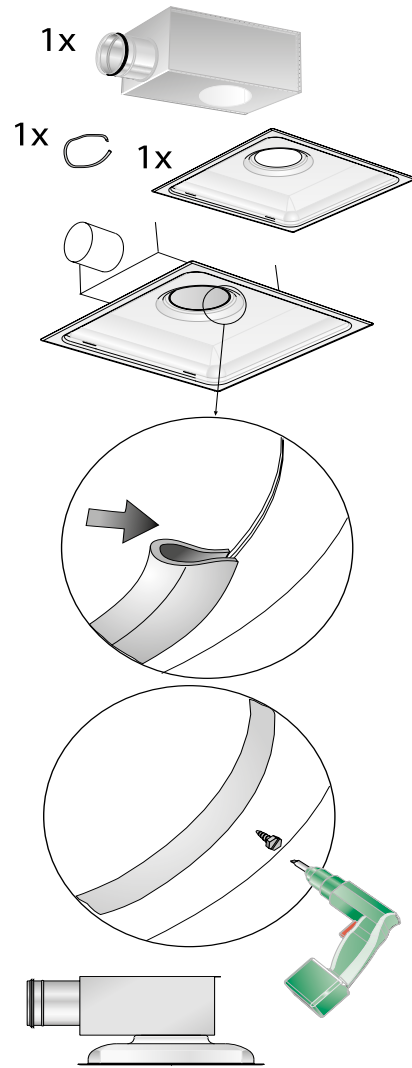

Figure 4. Installation of air diffusers and commissioning box with low installation height.

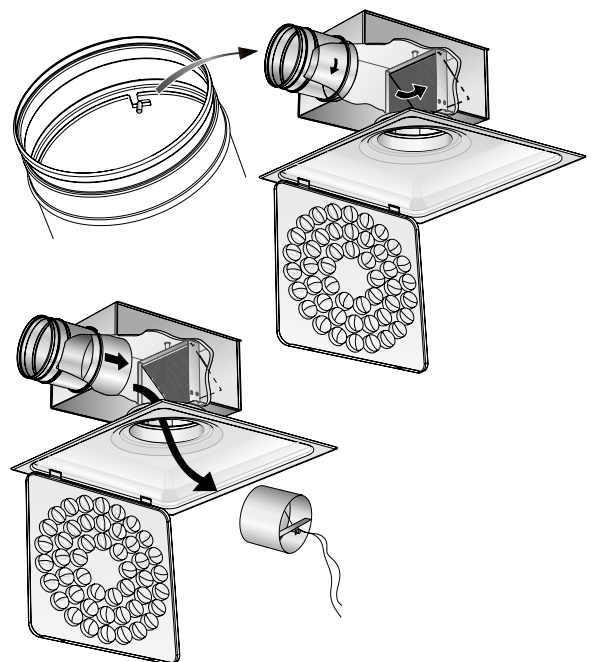

Figure 5. To dismantle the damper.

Dimensions and weights

COLIBRI Ceiling

Size	A	Ød	l	M	Weight, kg	Number of nozzles	
						CC	CR
125-400	395	124	375	70	1,5	47	49
125-600	595	124	575	70	3,5	47	49
160-400	395	159	375	70	1.5	47	49
160-600	595	159	575	70	3,5	47	49
200-500	495	199	475	70	2.5	90	100
200-600	595	199	575	70	3.5	90	100
250-600	595	249	575	70	3,5	130	169
315-600	595	314	575	50	3.5	130	169
400-600	595	399	575	50	3.5	130	169

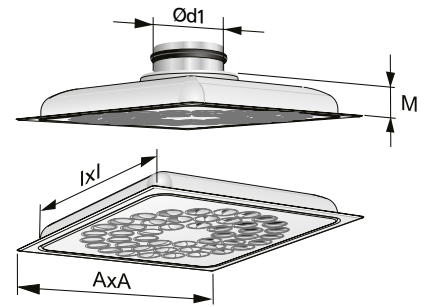

Figure 6. COLIBRI Ceiling

Dimensions of opening in ceiling = l x l

COLIBRI Ceiling with ALS, 1 step

Size	A	B	C	ØD	Ød	E1	E2	F1	F2	G1	G2	H	K	Weight, kg
125-400	395	282	217	99	125	255	212	113	70	175	132	270	80	3.5
125-600	595	282	217	99	125	255	212	113	70	175	132	270	80	5.5
160-400	395	342	252	124	160	279	236	113	70	188	145	315	80	4.2
160-600	595	342	252	124	160	279	236	113	70	188	145	315	80	6.2
200-500	495	404	288	159	200	314	271	113	70	205	162	375	100	6.0
200-600	595	404	288	159	200	314	271	113	70	205	162	375	100	7.0
250-600	595	504	332	199	250	354	311	113	70	225	182	465	115	8.7
315-600	595	622	388	249	315	395	352	93	50	230	187	575	140	11.8
400-600	595	767	488	314	400	455	-	93	-	262	-	712	175	15.0

COLIBRI Ceiling with ALS, 2 step

Size	A	B	C	ØD	Ød	E1	E2	F1	F2	G1	G2	H	K	Weight, kg
160-400	395	342	252	99	160	255	212	113	70	175	132	315	80	3,5
160-600	595	342	252	99	160	255	212	113	70	175	132	315	80	5,5
200-500	495	404	288	124	200	279	236	113	70	188	145	355	80	3,2
200-600	595	404	288	124	200	279	236	113	70	188	145	355	80	4,2
250-600	595	504	332	159	250	314	271	113	70	205	162	450	100	7,0
315-600	595	622	388	199	315	334	291	93	50	205	162	550	115	8,7

CL = Center line

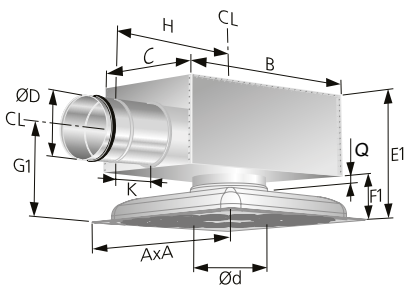

Figure 7. COLIBRI C with ALS.

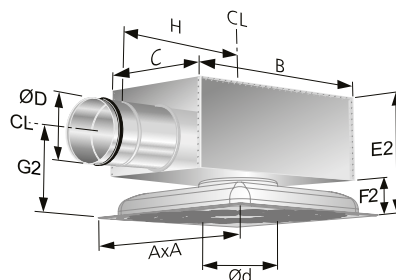

Figure 8. COLIBRI C with ALS. Low installation height.

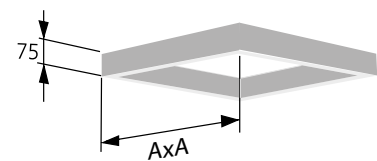

Figure 9. SAR K frame.

Nozzle pattern and nozzle settings

Standard and optional nozzle settings for various air distribution patterns.

 NOTE: Air direction in the figure. 

COLIBRI CC – Circular nozzle pattern

Clock-wise swirl
(standard)

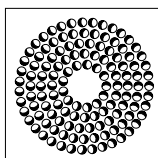

1-way

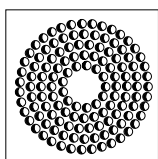

2-way

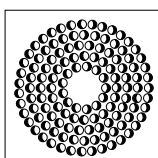

3-way

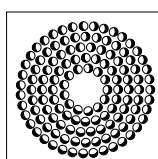

4-way

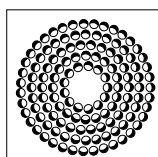

VK Vertical,
concentrated

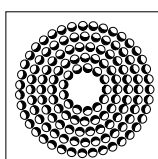

VD Vertical,
diffused

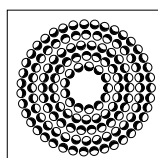

Counter-flow
distribution
pattern

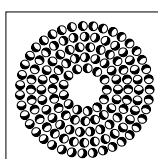

COLIBRI CR – Square nozzle pattern

Clock-wise swirl
(standard)

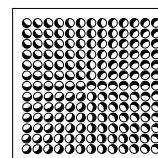

1-way

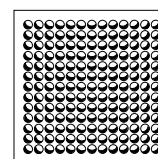

2-way
horizontal air diffusion

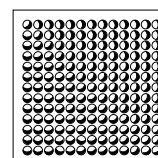

2-way clock-wise
swirl air diffusion

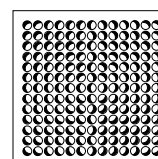

3-way

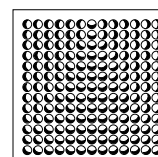

4-way

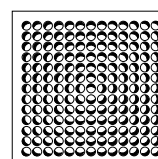

VK Vertical,
concentrated

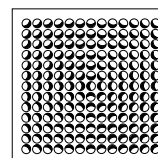

VD Vertical,
diffused

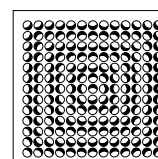

Coefficient of performance, COLIBRI Ceiling

COLIBRI CC, supply air

ALSd Size	COLIBRI CC, supply air			
	Size	Standard	Low version	Tube colour
100-125	125-400	7.3	7.0	Red
100-125	125-600	7.3	7.0	Red
100-160	160-400	9.3	8.9	Blue
100-160	160-600	9.3	8.9	Blue
125-160	160-400	9.8	9.3	Red
125-160	160-600	9.8	9.3	Red
125-200	200-500	15.6	14.5	Blue
125-200	200-600	15.6	14.5	Blue
160-200	200-500	16.8	15.2	Red
160-200	200-600	16.8	15.0	Red
200-250	250-500	19.7	-	Red
160-250	250-600	23.4	21.7	Blue
200-250	250-600	24.9	22.8	Red
200-315	315-500	20.9	-	Blue
250-315	315-500	21.3	-	Red
200-315	315-600	26.4	25.4	Blue
250-315	315-600	27.4	25.6	Red
315-400	400-600	32.5	-	Red

Number of measuring tubes: 1

COLIBRI CR, supply air

ALSd Size	COLIBRI CR, supply air			
	Size	Standard	Low version	Tube colour
100-125	125-400	7.4	7.2	Red
100-125	125-600	7.4	7.2	Red
100-160	160-400	9.5	9.2	Blue
100-160	160-600	9.5	9.2	Blue
125-160	160-400	10.0	9.6	Red
125-160	160-600	10.0	9.6	Red
125-200	200-500	16.7	15.5	Blue
125-200	200-600	16.7	15.5	Blue
160-200	200-500	17.7	16.5	Red
160-200	200-600	17.7	16.5	Red
200-250	250-500	21.7	-	Red
160-250	250-600	26.4	24.7	Blue
200-250	250-600	28.9	26.4	Red
200-315	315-500	23	-	Blue
250-315	315-500	23.2	-	Red
200-315	315-600	30.3	28.6	Blue
250-315	315-600	32.1	29.5	Red
315-400	400-600	37.7	-	Red

Number of measuring tubes: 1

COLIBRI CC, extract air

ALSd Size	COLIBRI CC, extract air		
	Size	Standard	Tube colour
100-125	125-600	3.9	Transparent
100-160	160-600	4.3	Transparent
125-160	160-600	5.8	Transparent
125-200	200-600	7	Transparent
160-200	200-600	9.6	Transparent
200-250	250-500	12.6	Transparent
200-315	315-500	14.2	Transparent
250-315	315-500	15.5	Transparent
200-250	250-600	14.4	Transparent
250-315	315-600	18.7	Transparent
315-400	400-600	25.5	Transparent

Number of measuring tubes: 1

COLIBRI CR, extract air

ALSd Size	COLIBRI CR, extract air		
	Size	Standard	Tube colour
200-250	250-600	16.2	Transparent
250-315	315-600	21.2	Transparent
315-400	400-600	29.1	Transparent

Number of measuring tubes: 1