

COMMISSIONING GUIDE

Version 2023:02

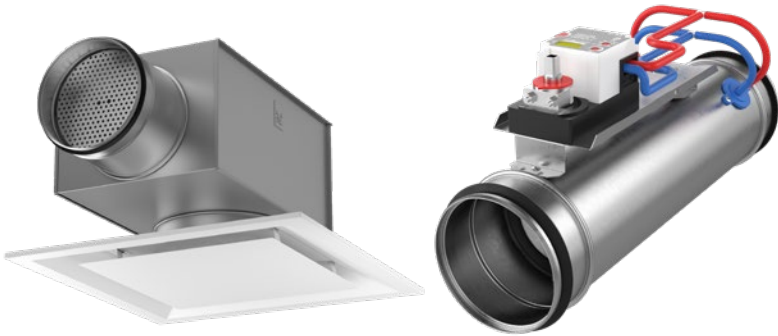

AIR DIFFUSERS
VAV/CAV - & COMMISSIONING DAMPERS

Measurement and commissioning	3	Air diffusers with circular commissioning box	28
Nozzle settings	5	COLIBRI Free	29
Air diffusers with commissioning box ALS	6	EAGLE Free	29
CBE	7	EXP Free	30
CDD	7	KITE Free	30
CDK	8	Displacement units	31
CDR	8	DBC	31
CKD	9	DBC	31
CKP	9	DIR	31
COLIBRI Ceiling – Circular nozzle pattern	10	DRI	31
COLIBRI Ceiling – Square nozzle pattern	11	DCP	32
COLIBRI Ceiling VF – Circular nozzle pattern	11	DIR	32
DPG	12	DHC	32
EAGLE Ceiling - Circular nozzle pattern	12	DVC	32
EAGLE Ceiling – Square nozzle pattern	13	DRI	32
EAGLE Single	14	Home air diffuser	33
EIV	14	DOMO	33
FALCON Ceiling	15	SDW	33
GRC	15	Duct diffuser	34
HAWK Ceiling	16	IBIS Control	34
KITE Ceiling	17	Extract air valves	35
LOCKZONE Base	17	ROE = EXC incl. robust protective cage	35
LOCKZONE Ceiling	18	EXF	35
LOCKZONE Ceiling VF	19	Linear diffusers	36
LPA	19	SWAN/SWAN Wall-To-Wall	36
PELICAN Ceiling – Supply	20	SRY	36
PELICAN Ceiling – Extract	20	VAV/CAV and commissioning damper	37
PELICAN Ceiling Extract – High Flow	20	REACT V & REACT M - Circular	37
ROC	21	REACT V -& REACT M - Rectangular	38
SWIFT Ceiling	21	SIRI	39
VIREO Ceiling	22	CRM 1	40
COLIBRI Wall	23	CRM 5	40
EAGLE Wall	24	Notes	41
LOCKZONE Wall	24		
PELICAN Wall	25		
ROW	25		
Air diffusers with commissioning box TRG	26		
ALG	26		
GRL	27		
GTH	27		

Measurement and commissioning

This guide presents measuring instructions for Swegon's measurable ventilation products.

The products are fitted with commissioning dampers and fixed measurement tappings, suitable for measuring reference pressure in accordance with standard SS-EN 16211:2015, "Air handling - Field methods for measuring air flows".

Product Versions

Presented K-factors refer to the current product version (for discontinued product versions, see older issues of this guide). The product version is indicated by a lower case letter after the upper case product name, for example:

- ALSd (product = ALS, product version = d)
- EAGLE CCa (product = EAGLE Ceiling Circular, product revision = a)

Instructions for measurement – Air diffusers:

- In ducts with fixed flow measurement units, method ID 3 applies.
- For extract air diffusers with fixed measurement tappings, method ET 12 applies.
- For supply air diffusers with fixed measurement tappings, method ST 1 applies. When measurement takes place in the commissioning box's inlet, method ST 11 applies, and when measurement takes place inside the commissioning box via a measurement tapping, ST 12 applies. Here, we distinguish between method ST 121, which relates to measurement via a single pressure socket, and method ST 122, which relates to measurement via two pressure sockets. Easily detachable measuring tubes are installed in the measurement tappings. In certain cases, the measuring tube is connected to a nipple drain with a cover. This cover must be closed when measurement is not being performed.

Procedure for measuring/commissioning – Air diffusers and duct products:

1. Determine the k-factor for the relevant diffuser with the aid of the commissioning guide.
2. Connect a pressure gauge to the measuring tube(s) or nipple drain.
3. One pressure reading, p_i (commissioning pressure), is read on the pressure gauge.
4. The air flow can now be calculated using the equation on the next page.
5. To change the air flow, adjust the damper. In individual products, the air flow is adjusted with plastic plugs or adjustable slots.

When the correct flow/pressure has been achieved, the damper control is locked as follows:

Supply air diffusers:

1. In those cases where the damper control comprises one white and one black nylon cord, the stretched cords must be tied together to create a commissioning knot. In this way, the set damper position can always be indicated.
2. The cords are wound once around the locking screw found in the product.
The damper position is locked by tightening the screw.

Extract air diffusers:

Takes place analogously with the supply air diffuser. In those cases where the diffuser is a control valve, the position of the cone is locked via a lock nut on the rear side of the diffuser.

Duct products (VAV/CAV & commissioning dampers):

On duct products where measurement/commissioning takes place using method ID 3, the damper's knob is fitted with a locking device.

Calculation of airflow – k-factor equations:

There is a specific balancing factor, k-factor, for each measurable Swegon product.

The products are normally marked with a k-factor.

The following equations are used to obtain the actual airflow or the balancing pressure that is valid for the designed airflow.

$$q = k \cdot \sqrt{p_i} \quad (\text{l/s})$$

q = measured airflow (l/s)

p_i = actual balancing pressure (Pa)

k = k-factor

$$p_i = \left(\frac{q}{k} \right)^2 \quad (\text{Pa})$$

p_i = balancing pressure at designed airflow (Pa)

q = designed airflow (l/s)

k = k-factor

If temperature and atmospheric pressure differ from standard settings (20 °C and 1013 mbar) at the time of commissioning, the balancing pressure is recalculated according to the following equation:

$$p_i = p_{i, \text{measured}} \cdot \frac{1,2}{\rho_{\text{time of measurement}}} \quad (\text{Pa})$$

Or the airflow can be recalculated to the standard settings according to:

$$q = q_{\text{measured}} \cdot \sqrt{\frac{1,2}{\rho_{\text{time of measurement}}}} \quad (\text{Pa})$$

Nozzle settings

Rotation

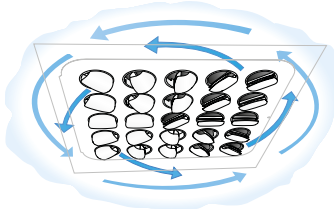

1-way

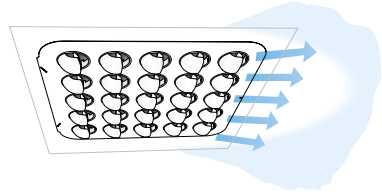

2H-way

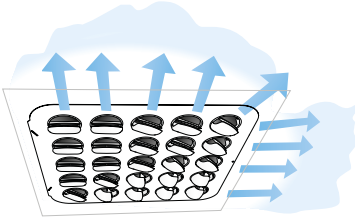

2M-way

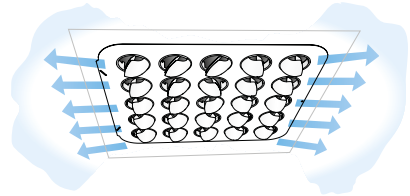

3-way

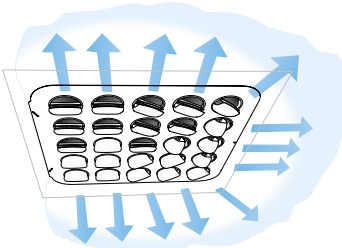

4-way

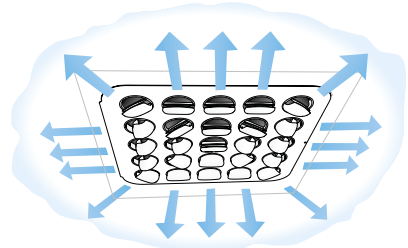

VK Vertical concentrated

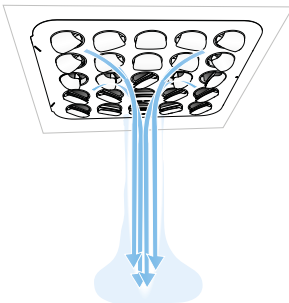

VD Vertical diffused

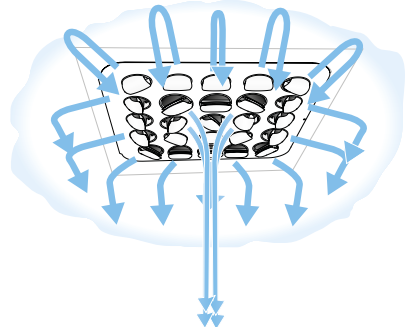

Air diffusers with commissioning box ALS

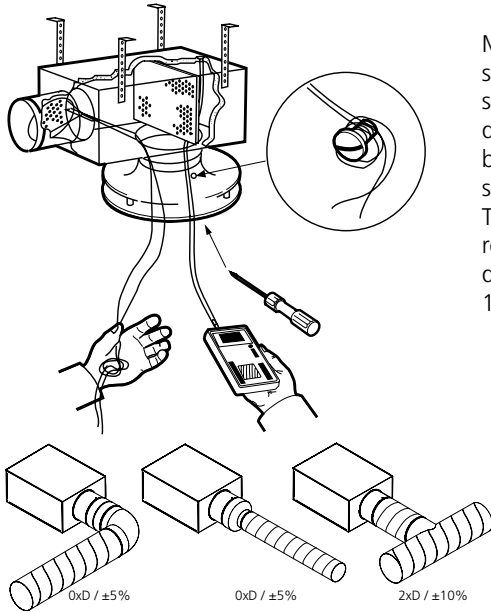

Measurement accuracy and requirement on straight duct before the commissioning box, see Figure 1. The requirements of straight duct depends on the type of disturbance before the commissioning box. Figure 1 shows a bend, a dimensional change and a T-piece. Other types of disturbances requires at least 2xD straight (D = connection dimension) for measurement accuracy of $\pm 10\%$ of the flow.

Figure 1. Example ALS, measurement with one tube according to standard SS-EN 16211:2015 and measurement method ST 121.

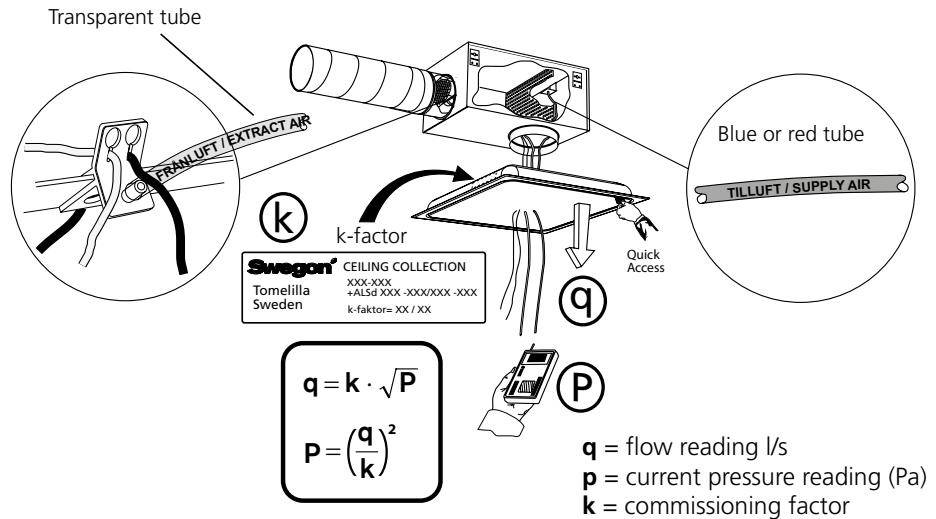

Figure 2. Example ALS, measurement with two tubes according to standard SS-EN 16211:2015 and measurement method ST 122.



CBE

ALSd	CBEa – supply air	
Size	Size	k-factor
80-100	100	4,6
100-125	125	7,3
125-160	160	11,9

Number of measuring tubes: 1

Tube colour: Red



CDD

ALSd	CDDb – supply air 360°			
Size	Size	Slot – 20 mm	Slot – 30 mm	Slot – 40 mm
80-100	100	5,8	6,1	–
100-125	125	8,2	8,9	–
125-160	160	–	14,4	15,0
160-200	200	–	21,3	23,4
200-250	250	–	24,4	31,1
250-315	315	–	34,6	43,3

Number of measuring tubes: 1

Tube colour: Red

ALSd	CDDb - extract air		
Size	Size	Slot - 20 mm	Slot - 30 mm
80-100	100	3,2	-
100-125	125	4,1	-
125-160	160	-	6,5
160-200	200	-	10,4
200-250	250	-	16
250-315	315	-	22,1

Number of measuring tubes: 1

Tube colour: Transparent

Air diffusers with commissioning box ALS



CDK

ALSd	CDKa – supply air 360°			
Size	Size	Slot – 20 mm	Slot – 30 mm	Slot – 40 mm
80-100	100	6,8	6,9	–
100-125	125	9,8	10,1	–
125-160	160		16,3	
160-200	200	–	26,9	27,6
200-250	250	–	38,5	42,1
250-315	315	–	57,6	69,9

Number of measuring tubes: 1
Tube colour: Red



CDR

ALSd	CDRb – supply air 360°			
Size	Size	Slot – 20 mm	Slot – 30 mm	Slot – 40 mm
80-100	100	5,0	5,6	–
100-125	125	7,1	8,1	–
125-160	160	–	13,1	13,9
160-200	200	–	18,4	20,3
200-250	250	–	24,3	28,5
250-315	315	–	36,1	42,6

Number of measuring tubes: 1
Tube colour: Red

ALSd	CDRb - extract air		
Size	Size	Slot - 20 mm	Slot - 30 mm
80-100	100	3,1	-
100-125	125	3,8	-
125-160	160	-	6,9
160-200	200	-	10,8
200-250	250	-	14,9
250-315	315	-	22,8

Number of measuring tubes: 1
Tube colour: Transparent

**CKD**

ALSd	CKDa – supply air		
Size	Size	Diffused	Concentrated
160-200	200	13,9	12,6
200-250	250	22,8	21,1
250-315	315	34,7	32,3
315-400	400	55,8	52,9

Number of measuring tubes: 1
 Tube colour: Red

**CKP**

ALSd	CKPa – supply air 360°			
Size	Size	Slot – 20 mm	Slot – 30 mm	Slot – 40 mm
80-100	100	3,8	6,8	–
100-125	125	9,9	10,1	–
125-160	160	–	16,2	16,5
160-200	200	–	27,3	27,9
200-250	250	–	39,8	42,2
250-315	315	–	60,6	68,7

Number of measuring tubes: 1
 Tube colour: Red



COLIBRI Ceiling – Circular nozzle pattern

ALSd	COLIBRI CCb – supply air			
Size	Size	Standard	Low version	Tube colour
100-125	125-400	7,3	7,0	Red
100-125	125-600	7,3	7,0	Red
100-160	160-400	9,3	8,9	Blue
100-160	160-600	9,3	8,9	Blue
125-160	160-400	9,8	9,3	Red
125-160	160-600	9,8	9,3	Red
125-200	200-500	15,6	14,5	Blue
125-200	200-600	15,6	14,5	Blue
160-200	200-500	16,8	15,2	Red
160-200	200-600	16,8	15,0	Red
200-250	250-500	19,7	-	Blue
160-250	250-600	23,4	21,7	Red
200-250	250-600	24,9	22,8	Blue
200-315	315-500	20,9	-	Red
250-315	315-500	21,3	-	Red
200-315	315-600	26,4	25,4	Blue
250-315	315-600	27,4	25,6	Red
315-400	400-600	32,5	-	Red

Number of measuring tubes: 1

ALSd	COLIBRI CCb – extract air	
Size	Size	Standard
200-250	250-600	14,4
250-315	315-600	18,7
315-400	400-600	25,5

Number of measuring tubes: 1

Tube colour: Transparent



COLIBRI Ceiling – Square nozzle pattern

ALSd	COLIBRI CRb – supply air				
	Size	Size	Standard	Low version	Tube colour
100-125	125-400	7,4		7,2	Red
100-125	125-600	7,4		7,2	Red
100-160	160-400	9,5		9,2	Blue
100-160	160-600	9,5		9,2	Blue
125-160	160-400	10,0		9,6	Red
125-160	160-600	10,0		9,6	Red
125-200	200-500	16,7		15,5	Blue
125-200	200-600	16,7		15,5	Blue
160-200	200-500	17,7		16,5	Red
160-200	200-600	17,7		16,5	Red
200-250	250-500	21,7		-	Blue
160-250	250-600	26,4		24,7	Red
200-250	250-600	28,9		26,4	Blue
200-315	315-500	23		-	Red
250-315	315-500	23,2		-	Red
200-315	315-600	30,3		28,6	Blue
250-315	315-600	32,1		29,5	Red
315-400	400-600	37,7		-	Red

Number of measuring tubes: 1

ALSd	COLIBRI CRb – extract air	
	Size	Standard
200-250	250-600	16,2
250-315	315-600	21,2
315-400	400-600	29,1

Number of measuring tubes: 1

Tube colour: Transparent



COLIBRI Ceiling VF – Circular nozzle pattern

ALSd	COLIBRI CC VFa – supply air			
	Size	Size	Standard	Tube colour
160-250	250-600		20,6	Blue
200-250	250-600		21,7	Red
200-315	315-600		28,6	Blue
250-315	315-600		29,5	Red

Number of measuring tubes: 1

Air diffusers with commissioning box ALS



DPG

ALSd	DPGa – supply air	
Size	Size	k-factor
100-125	125-0	3,8

Number of measuring tubes: 1

Tube colour: Red



EAGLE Ceiling - Circular nozzle pattern

ALSd	EAGLE CCa – supply air			
Size	Size	Standard	Low version	Tube colour
100-125	125-400	7,8	7,8	Red
100-125	125-600	8,3	8	Red
100-160	160-400	11,6	11,3	Blue
100-160	160-600	11,3	10,7	Blue
125-160	160-400	12	11,7	Red
125-160	160-600	12,2	11,3	Red
125-200	200-500	16,4	15,2	Blue
125-200	200-600	17	16,1	Blue
160-200	200-500	18,4	16,7	Red
160-200	200-600	18,9	17,6	Red
200-250	250-500	28,5	25,7	Blue
160-250	250-600	25,3	23,6	Red
200-250	250-600	28,6	24,8	Blue
200-315	315-500	31,6	28,9	Red
250-315	315-500	32,9	30,7	Red
200-315	315-600	35,9	32	Blue
250-315	315-600	38,6	33,9	Red
315-400	400-600	49,5	45,2	Red

Number of measuring tubes: 1

ALSd	EAGLE CCa – extract air	
Size	Size	Standard
200-250	250-600	17,5
250-315	315-600	26,6
315-400	400-600	36

Number of measuring tubes: 1

Tube colour: Transparent



EAGLE Ceiling – Square nozzle pattern

ALSd	EAGLE CRa – supply air			
Size	Size	Standard	Low version	Tube colour
100-125	125-400	7,8	7,6	Red
100-125	125-600	7,7	7,6	Red
100-160	160-400	11,8	11,5	Blue
100-160	160-600	11,8	11,2	Blue
125-160	160-400	12,6	11,9	Red
125-160	160-600	12,6	11,7	Red
125-200	200-500	17,6	16,9	Blue
125-200	200-600	17,6	16,7	Blue
160-200	200-500	19,9	17,9	Red
160-200	200-600	19,9	17,9	Red
200-250	250-500	28,6	-	Blue
160-250	250-600	26,5	24,1	Red
200-250	250-600	28,2	25,9	Blue
200-315	315-500	31,2	-	Red
250-315	315-500	33,2	-	Red
200-315	315-600	35,2	32,2	Blue
250-315	315-600	37,3	33,5	Red
315-400	400-600	53,1	-	Red

Number of measuring tubes: 1

ALSd	EAGLE CRa – extract air	
Size	Size	Standard
200-250	250-600	18,6
250-315	315-600	26,4
315-400	400-600	39,6

Number of measuring tubes: 1

Tube colour: Transparent



EAGLE Single

ALSd	EAGLE Sb – supply air
Size	k-factor
100-125	7,5
125-160	12,1
160-200	20,1
200-250	29,8
250-315	42,3
315-400	67,8

Number of measuring tubes: 1

Tube colour: Red



EIV

ALSd	EIVa – supply air	
Size	Size	k-factor
80-80	80	4,6
80-100	100	5,9
100-125	125	8,2
125-160	160	10,3

Number of measuring tubes: 1

Tube colour: Red



FALCON Ceiling

ALSd	FALCON Ca – supply air 360°		
Size	Size	Horizontal	Vertical
100-125	125	8,6	6,8
125-160	160	13,5	8,5
160-200	200	20,6	13,2
200-250	250	32,5	19,5
250-315	315	50,2	33,3
315-400	400	82,8	51,0
400-500	500	125,0	79,5

Number of measuring tubes: 1
Tube colour: Red



GRC

ALSd	GRCa – extract air	
Size	Size	k-factor
80-100	100	3,0
100-125	125	4,9
125-160	160	8,2
160-200	200	12,7
200-250	250	22,2
250-315	315	34,0
315-400	400	59,6
400-500	500	95,0

Number of measuring tubes: 1
Tube colour: Transparent



HAWK Ceiling

ALSd	HAWK Ca – supply air			
Size	Size	Standard	Low version	Tube colour
100-125	125-600	8,4	8,0	Red
100-160	160-600	11,7	10,9	Blue
125-160	160-600	12,3	11,9	Red
125-200	200-600	19,1	17,0	Blue
160-200	200-500	20,9	18,2	Red
160-200	200-600	29,1	25,7	Blue
200-250	250-500	28,4	-	Red
200-250	250-600	32,5	28,5	Blue
200-315	315-500	30,3	-	Red
250-315	315-500	31,8	-	Red
200-315	315-600	37,0	34,2	Blue
250-315	315-600	39,4	35,3	Red
315-400	400-600	50,9	-	Red

Number of measuring tubes: 1

ALSd	HAWK Ca – extract air	
Size	Size	Standard
200-250	250-600	19,1
250-315	315-600	25,4
315-400	400-600	34,9

Number of measuring tubes: 1

Tube colour: Transparent



KITE Ceiling

ALSd		KITE CRa – supply air				
Size	Size	Standard	Blanking off		Low version	Tube colour
			3-way*	1-way/ 2-way corner/ 2-way middle**		
100-125	125-600	9,2	8,9	8,2	8,1	Red
100-160	160-600	12,8	11,6	9,9	11,2	Blue
125-160	160-600	13,9	12,7	10,6	11,6	Red
125-200	200-600	18,6	16,4	12,4	15,8	Blue
160-200	200-600	20,1	18,1	13,3	16,4	Red
160-250	250-600	24,5	19,7	13,8	20,4	Blue
200-250	250-600	25,6	21	14,2	20,3	Red
200-315	315-600	29,8	22,7	15,3	25,8	Blue
250-315	315-600	30,1	23,2	15,3	24,6	Red

Number of measuring tubes: 1

* When using 1 blanking plate.

** When using 2 blanking plates.

ALSd		KITE CRa – extract air	
Size	Size	Standard	Low version
100-125	125-600	4,9	4,2
100-160	160-600	5	4,7
125-160	160-600	7,2	6,5
125-200	200-600	8,3	7,8
160-200	200-600	11,7	10,5
160-250	250-600	13,1	12,4
200-250	250-600	17	14,9
200-315	315-600	19	17,5
250-315	315-600	21,6	19,3

Number of measuring tubes: 1

Tube colour: Transparent



LOCKZONE Base

ALSd		LOCKZONE Bb – supply air	
Size	Size	Size	k-factor
80-100		100	3,4
100-125		125	3,7
125-160		160	5,6
160-200		200	11,2

Number of measuring tubes: 1

Tube colour: Red



LOCKZONE Ceiling

ALSd	LOCKZONE Ca – supply air			
Size	Size	Standard	Low version	Tube colour
100-125	125-400	8,3	7,9	Red
100-125	125-600	8,2	7,8	Red
100-160	160-400	11,1	10,8	Blue
100-160	160-600	11,2	10,8	Blue
125-160	160-400	12,1	11,4	Red
125-160	160-600	12,4	11,4	Red
125-200	200-500	18,0	16,9	Blue
125-200	200-600	17,8	16,9	Blue
160-200	200-500	19,7	18,4	Red
160-200	200-600	19,7	18,0	Red
200-250	250-500	27,4	-	Blue
160-250	250-600	28,1	25,6	Red
200-250	250-600	30,9	27,4	Blue
200-315	315-500	31,6	-	Red
250-315	315-500	33,2	-	Red
200-315	315-600	36,5	35,1	Blue
250-315	315-600	39,6	39,6	Red
315-400	400-600	56	-	Red

Number of measuring tubes: 1

ALSd	LOCKZONE Ca – extract air	
Size	Size	Standard
200-250	250-600	18,4
250-315	315-600	27,1
315-400	400-600	42,5

Number of measuring tubes: 1

Tube colour: Transparent



LOCKZONE Ceiling VF

ALSd	LOCKZONE C VFa – supply air		
Size	Size	k-factor	Tube colour
160-250	250-600	25,8	Blue
200-250	250-600	27,9	Red
200-315	315-600	34,7	Blue
250-315	315-600	37,1	Red

Number of measuring tubes: 1



LPA

ALSd	LPAa – Supply air	
Size	Size	k-factor
125-160	160	11,0
160-200	200	18,1
200-250	250	27,5
250-315	315	38,0
315-400	400	58,7

Number of measuring tubes: 1
Tube colour: Red

ALSd	LPAa – Extract air	
Size	Size	k-factor
125-160	160	7,0
160-200	200	11,5
200-250	250	17,7
250-315	315	28,5
315-400	400	41,6

Number of measuring tubes: 1
Tube colour: Transparent



PELICAN Ceiling – Supply

ALSd		PELICAN CSa – Supply air		
Size	Size	Standard	Low version	Tube colour
100-125	125-400	7,1	7,7	Red + Red
100-125	125-600	7,1	7,7	Red + Red
100-160	160-400	10,6	10,1	Blue + Red
100-160	160-600	10,6	10,1	Blue + Red
125-160	160-400	11,4	11,8	Red + Red
125-160	160-600	11,4	11,8	Red + Red
125-200	200-600	16,0	16,5	Blue + Red
160-200	200-600	18,1	19,0	Red + Red
200-250	250-500	30,7	-	Red + Red
160-250	250-600	25,7	27,1	Blue + Red
200-250	250-600	29,0	28,4	Red + Red
200-315	315-500	37,5	-	Blue + Red
250-315	315-500	45,4	-	Red + Red
200-315	315-600	37,6	36,1	Blue + Red
250-315	315-600	44,0	38,1	Red + Red
315-400	400-600	68,2	-	Red

Number of measuring tubes: 2 (Size 400-600: 1 measuring tube)



PELICAN Ceiling – Extract

ALSd		PELICAN CEa – extract air	
Size	Size	Standard	Low version
100-125	125-400	4,9	4,6
125-160	160-400	7,6	7,2
160-200	200-600	14,2	12,6
200-250	250-500	20,7	-
200-250	250-600	21,2	20,2
200-315	315-500	22,9	-
250-315	315-500	29,2	-
250-315	315-600	27,9	27,7
315-400	400-600	41,6	-

Number of measuring tubes: 1

Tube colour: Transparent



PELICAN Ceiling Extract – High Flow

ALSd		PELICAN CE HFa – extract air	
Size	Size	Size	k-factor
	125-160	160-600	8,1
	160-200	200-600	13,3
	160-250	250-500	14,7
	200-250	250-500	20,8
	200-250	250-600	20,5
	200-315	315-500	22,8
	250-315	315-500	32,5
	250-315	315-600	32,1
	315-400	400-600	49,6

Number of measuring tubes: 1

Tube colour: Transparent



ROC

ALSd	ROCa – supply air	
Size	Size	k-factor
80-100	100	4,6
100-125	125	7,5
125-160	160	11,6
160-200	200	19,7
200-250	250	32,6
250-315	315	43,4
315-400	400	52,1

Number of measuring tubes: 1
Tube colour: Red

ALSd	ROCa – extract air	
Size	Size	k-factor
80-100	100	3,2
100-125	125	4,5
125-160	160	7
160-200	200	12
200-250	250	19,2
250-315	315	28,6
315-400	400	40

Number of measuring tubes: 1
Tube colour: Transparent



SWIFT Ceiling

ALSd	SWIFT Ca – supply air	
Size	Size	k-factor
160-200	200-500	18,1
200-250	250-500	22,2
160-200	200-600	20,7
200-250	250-600	28,0
250-315	315-600	32,4

Number of measuring tubes: 1
Tube colour: Red

ALSd	SWIFT Ca – extract air	
Size	Size	k-factor
200-250	250-500	14,2
200-250	250-600	15,9
250-315	315-600	22,6

Number of measuring tubes: 1
Tube colour: Transparent



VIREO Ceiling

ALSd		VIREO Ca – supply air	
Size	Size	k-factor	Tube colour
100-125	125-600	7,7	Red
100-160	160-600	10,7	Blue
125-160	160-600	11,6	Red
125-200	200-600	16,9	Blue
160-200	200-600	18,7	Red
160-250	250-600	23,7	Blue
200-250	250-600	24,2	Red
200-315	315-600	33,0	Blue
250-315	315-600	34,7	Red
250-400	400-600	41,1	Blue
315-400	400-600	43,2	Red

Number of measuring tubes: 1

ALSd		VIREO Ca – extract air	
Size	Size	k-factor	
160-250	250-600	12,9	
200-250	250-600	17,3	
200-315	315-600	19,5	
250-315	315-600	26,4	
250-400	400-600	29,8	
315-400	400-600	38,2	

Number of measuring tubes: 1

Tube colour: Transparent



EAGLE Wall

ALVe	EAGLE Wb – supply air				
Size	Size	Back side connection		Short side connection	
		Closed slot	Open slot	Closed slot	Open slot
300-150-100	300-100	7,8	9,2	7,2	8,1
400-150-125	400-150	9,9	11,8	9,6	11,1
400-200-160	400-200	14,8	17,1	14,0	15,9
550-250-200	550-250	25,5	27,8	24,4	26,8
550-300-250	550-300	31,1	33,9	30,5	33,4

Connection alternatives: B = Back side, K = Short side

Number of measuring tubes: 1

Tube colour: Transparent



LOCKZONE Wall

ALVe	LOCKZONE Wa – supply air	
Size	Back side connection	Short side connection
300-150	7,4	6,9
400-150	10,0	9,9
400-200	15,0	14,3
550-250	26,3	24,9
550-300	32,4	32,0

Connection alternatives: B = Back side, K = Short side

Number of measuring tubes: 1

Tube colour: Transparent



PELICAN Wall

ALVe	PELICAN Wa – supply air		
Size	Size	Back side connection	Short side connection
300-150-100	300-100	8,8	8,1
400-150-125	400-150	10,9	11,1
400-200-160	400-200	17,3	17,3
550-250-200	550-250	25,6	25,1
550-300-250	550-300	32,2	32,6

Connection alternatives: B = Back side, K = Short side

Number of measuring tubes: 1

Tube colour: Transparent



ROW

ALVe	ROWb – supply air		
Size	Size	Back side connection	Short side connection
400-150-125	400-150	10,0	9,9
400-200-160	400-200	15,0	14,3

Connection alternatives: B = Back side, K = Short side

Number of measuring tubes: 1

Tube colour: Transparent

Air diffusers with commissioning box TRG

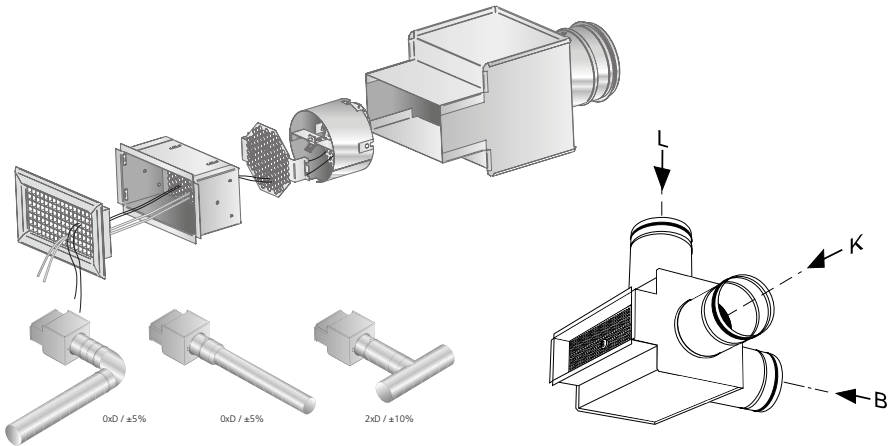

Figure 4. Example TRGd, measurement with two tubes according to standard SS-EN 16211:2015 and measurement method ST 122, as well as connection options, B = rear side, K = short side, L = long side.



ALG

TRGd	ALGc – supply air			ALGc – extract air		
	B	K	L	B	K	L
200-100-125	7,2	7,1	7,4	7,6	7,7	7,2
300-100-160	11,9	12,2	12,3	13,4	13,0	12,3
400-100-160	15,9	16,2	15,5	19,3	18,2	17,4
500-100-200	21,4	21,4	22,2	23,2	23,0	21,2
300-150-200	19,6	19,4	20,2	20,9	21,4	19,2
400-150-250	26,9	26,3	27,3	28,9	28,2	26,4
500-150-250	35,0	34,5	32,4	36,3	35,7	33,3
400-200-250	36,8	38,5	42,0	45,6	44,3	41,0
500-200-315	52,4	50,8	48,5	56,3	56,1	51,5
600-200-315	61,9	60,7	57,6	70,7	69,6	61,0

Connection alternatives: B = Back side, K = Short side, L = Long side

Number of measuring tubes: 2

Tube colours: Transparent + Blue

**GRL**

TRGd	GRLc – extract air		
Size	B	K	L
200-100-125	7,9	8,5	7,0
300-100-160	13,3	13,2	11,8
400-100-160	18,9	18,5	16,9
500-100-200	23,2	23,3	21,0
300-150-200	21,0	20,9	18,5
400-150-250	29,1	28,4	25,3
500-150-250	36,6	35,7	32,4
400-200-250	46,6	42,9	39,8
500-200-315	56,8	55,4	47,9
600-200-315	70,0	68,5	59,4
600-300-400	109,0	107,0	104,0

Connection alternatives: B = Back side, K = Short side, L = Long side

Number of measuring tubes: 2

Tube colours: Transparent + Blue

**GTH**

TRGd	GTHc – supply air – straight blades			GTHc – supply air – blades 45°		
Size	B	K	L	B	K	L
200-100-125	7,5	7,2	7,3	7,2	7,0	7,1
300-100-160	12,1	12,1	12,3	11,3	11,9	12,1
400-100-160	16,2	16,6	15,4	15,0	16,1	15,0
500-100-200	21,1	20,7	22,1	20,1	20,4	21,1
300-150-200	19,3	19,2	19,7	19,4	18,8	19,2
400-150-250	26,5	26,1	27,9	25,4	25,8	26,6
500-150-250	34,8	33,5	32,9	33,8	33,4	30,9
400-200-250	38,1	39,2	41,2	37,4	38,1	41,1
500-200-315	50,5	48,4	48,3	48,0	48,2	46,4
600-200-315	60,3	58,7	56,6	57,6	57,8	54,4

Connection alternatives: B = Back side, K = Short side, L = Long side

Number of measuring tubes: 2

Tube colours: Transparent + Blue

Air diffusers with circular commissioning box

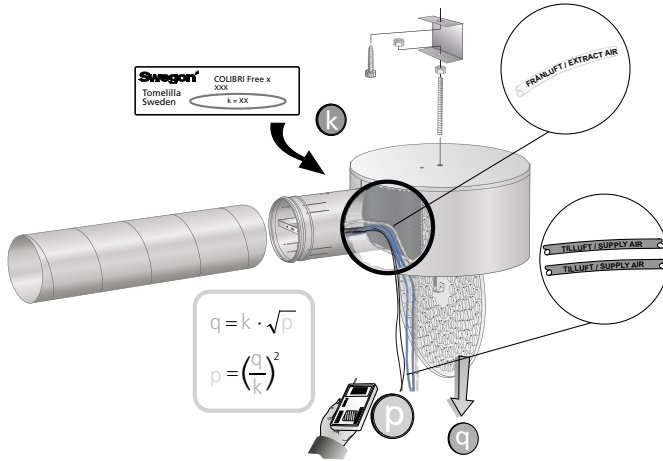

Figure 5. Example circular commissioning box, measurement with two tubes according to standard SS-EN 16211:2015 and measurement method ST 11.

Type of obstruction upstream	Length of straight duct upstream	
	$m_2 = 5\%$	$m_2 = 10\%$
One 90° bend	3 · Ød	2 · Ød
Two 90°bends in the same plane	4 · Ød	2 · Ød
Two 90° bends in alignment at right angles to one another.	4 · Ød	2 · Ød
One 45° damper	6 · Ød	3 · Ød
One T-piece	4 · Ød	3 · Ød

u_2 = error of method according to standard SS-EN 16211:2015



COLIBRI Free

COLIBRI Fb - supply air	
Size	k-factor
100	4,9
125	8,3
160	14,6
200	24,1
250	36,4
315	59,2
400	100,0

Number of measuring tubes: 2
 Tube colour: Blue + Blue

COLIBRI Fb - extract air	
Size	k-factor
100	5,0
125	7,7
160	12,8
200	21,0
250	26,2
315	38,3
400	44,7

Number of measuring tubes: 1
 Tube colour: Transparent



EAGLE Free

EAGLE Fg – supply air	
Size	k-factor
100	4,9
125	8,3
160	14,6
200	24,1
250	36,3
315	59,7
400	101,0

Number of measuring tubes: 2
 Tube colours: Blue + Blue

EAGLE Fg – extract air	
Size	k-factor
100	5,7
125	9,0
160	15,2
200	24,3
250	32,9
315	49,4
400	68,4

Number of measuring tubes: 1
 Tube colour: Transparent



EXP Free

EXP Fb - extract air	
Size	k-factor
100	5,3
125	8,6
160	14,5
200	24,1
250	36,3
315	57,5
400	82,4

Number of measuring tubes: 1

Tube colour: Transparent

NOTE! The blue tubes can be used if the product is converted for supply air with the distributor being replaced with nozzles for COLIBRI Fb and EAGLE Fg.



KITE Free

KITE Fa - supply air	
Size	k-factor
125	8,2
160	14,7
200	24,2
250	36,1
315	59,7

Number of measuring tubes: 2

Tube colours: Blue + Blue

K-factors also apply for KITE Free with blanking plate.

KITE Fa - extract air	
Size	k-factor
125	8,8
160	14,9
200	21,9
250	31,8
315	43,9

Number of measuring tubes: 1

Tube colour: Transparent

Displacement units

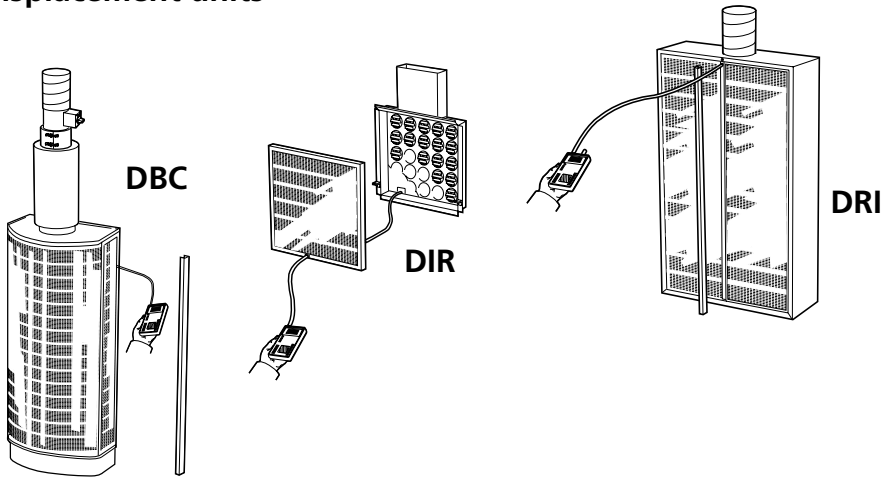

Figure 6. Example low velocity diffuser, measurement with one tube according to standard SS-EN 16211:2015 and measurement method ST 121



DBC

Size	DBC _a – supply air
200	34,0
250	54,0
315	89,5
400	142,5
200-600	122,0
300-600	185,0

Number of measuring tubes: 1

Displacement units



DCP



DHC



DVC

Size	DCPe – supply air	DHCe – supply air	DVCe – supply air
125	12,2	12,0	12,0
160	22,8	20,0	20,0
200	37,0	33,0	33,0
250	58,0	50,0	50,0
315	88,0	84,0	84,0
400	141,0	134,0	134,0
500	210,0	202,0	–
630	295,0	285,0	–
800	–	520,0	–

Number of measuring tubes: 1



DIR



DRI

Size	DIRc – supply air	DRIf – supply air
400-100	13,1	–
500-125	18,7	–
600-160	23,5	–
900-200	46,8	–
200	–	32,0
250	–	53,0
315	–	85,0
400	–	130,0
200-600	–	120,0
250-800	–	176,0

Number of measuring tubes: 1

Home air diffuser



DOMO

DOMOc	
Adjustment	k-factor
R 1	1,3
R 2	2,3
R 3	3,3
R 4	3,9



SDW

Measurement pressure 5 Pa required to obtain at least $\pm 10\%$ accuracy on the air flow.

SDWa		
Adjustment	Number of magnetic strips (R)	k-factor
80	R0	8,7
80	R1	6,6
80	R2	6,6
80	R3	4,1
80	R4	3,4
80	R5	2,1
80	R6	1,0
100	R0	6,2
100	R1	5,8
100	R2	4,9
100	R3	4,2
100	R4	3,0
100	R5	2,0
100	R6	1,0
125	R0	7,0
125	R1	6,1
125	R2	5,2
125	R3	4,2
125	R4	3,0
125	R5	2,0
125	R6	1,0

Application of strips

R0 = Without magnetic strips

R1 = Covers the 3 uppermost rows of holes

R2 = Covers the 3 uppermost and 3 lowermost rows of holes

R3 = Covers the 6 uppermost and 3 lowermost rows of holes

R4 = Covers the 6 uppermost and 6 lowermost rows of holes

R5 = 5 rows in the middle are open

R6 = 2 rows in the middle are open

Duct diffuser



IBIS Control

Size	IBIS Ca – Adjustable measuring unit
160-1500	14,8
200-1500	22,5
250-1500	36,1
315-1500	61,2
400-1500	96,0

Number of measuring tubes: 2 (according to standard SS-EN 16211:2015 and measurement method ID 32)

Type of obstruction upstream of the IBIS C	Length of straight duct (L) upstream of the IBIS C	
	For $m_2=5\%$	For $m_2=10\%$
One 90° bend.	3 x Ød	2 x Ød
Two 90° bends in the same plane.	4 x Ød	2 x Ød
Two 90° bends in alignment at right angles to one another.	4 x Ød	2 x Ød
One 45° damper.	6 x Ød	3 x Ød
One T-piece.	4 x Ød	3 x Ød

u_2 = error of method according to standard SS-EN 16211:2015 and measurement method ID 32.

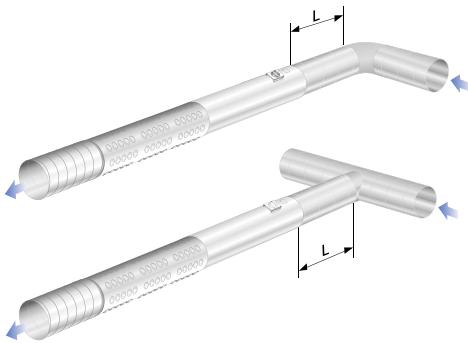

Figure 7. Planning.

Extract air valves

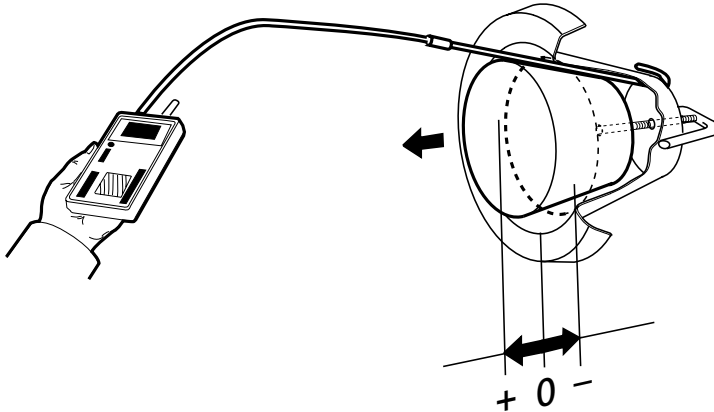

Figure 8. Example extract air diffuser, measurement with one tube according to standard SS-EN 16211:2015 and measurement method ET 1 with test probe



**ROE = EXC incl.
robust protective
cage**



EXF

ROEa, EXCa – k-factor for each size depending on cone position				
Cone position	100	125	160	200
-15	0,6	–	–	–
-12	0,8	–	–	–
-10	1,0	1,3	2,0	–
-5	1,4	1,9	2,8	–
-3	–	–	–	1,8
0	1,8	2,6	3,6	2,6
+5	2,3	3,2	4,5	3,8
+10	2,7	3,9	5,4	5,2
+15	–	–	6,2	6,4
+20	–	–	–	7,5
+25	–	–	–	8,6

Measured by pressure gauge.

EXF – k-factor for each size depending on cone position			
Cone position	100	125	160
-15	0,6	1,4	2,0
-10	1,1	2,2	3,1
-5	1,7	3,0	4,0
0	2,2	3,8	4,9
5	2,8	4,9	5,9
10	3,3	5,6	6,8
15	4,5	6,1	7,8

Measured by pressure gauge.

Linear diffusers



SWAN/SWAN Wall-To-Wall

SWAN Ta	SWANa/W-T-Wa – supply air		
Size ^{*)}	1-way	2-way	vertical
2-160	21,0	21,0	18,8
2-200	22,4	22,4	19,8
2-250	23,4	23,4	19,8
3-160	27,1	–	24,9
3-200	29,4	–	25,8
3-250	32,2	–	25,8
4-160	27,6	27,6	25,1
4-200	35,4	35,4	30,8
4-250	39,0	39,0	34,2

Number of measuring tubes: 1

Supply air: Blue

^{*)} First figure indicates the number of slots

SWAN Ta	SWANa/W-T-Wa – extract air
Size ^{*)}	k-factor
2-160	13,0
2-200	16,6
2-250	18,7
3-160	15,8
3-200	19,3
3-250	22,8
4-160	16,7
4-200	22,5
4-250	29,1

Number of measuring tubes: 1

Extract air: Transparent

^{*)} First figure indicates the number of slots

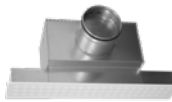

SRY

SRYT 1b	SRYb – supply air			
Size	Size ^{**)}	k-factor	Size ^{**)}	k-factor
1-500-125-L	1-900-1	4,5	1-1200-1	5,3
2-500-160-L	2-900-1	8,6	2-1200-2	6,5
3-500-160-L	3-900-1	12,4	3-1200-2	9,4
4-500-200-L	4-900-1	16,2	4-1200-2	12,4
1-500-125-L	1-1500-2	4,2	1-1800-2	4,6
2-500-160-L	2-1500-2	7,8	2-1800-2	8,6
3-500-200-L	3-1500-2	11,4	3-1800-2	13,0
4-500-200-L	4-1500-2	14,4	4-1800-3	12,4

Note! The K-factor is valid for one commissioning box. Ex: With two or three commissioning boxes for one diffuser, the total of the designed airflow shall be divided by the number of commissioning boxes.

Number of measuring tubes: 1

^{**) Last figure indicates the number of commissioning boxes}

VAV/CAV and commissioning damper

- measurement method ID 31 without damper
 - measurement method ID 32 with damper
- according to standard SS-EN 16211:2015

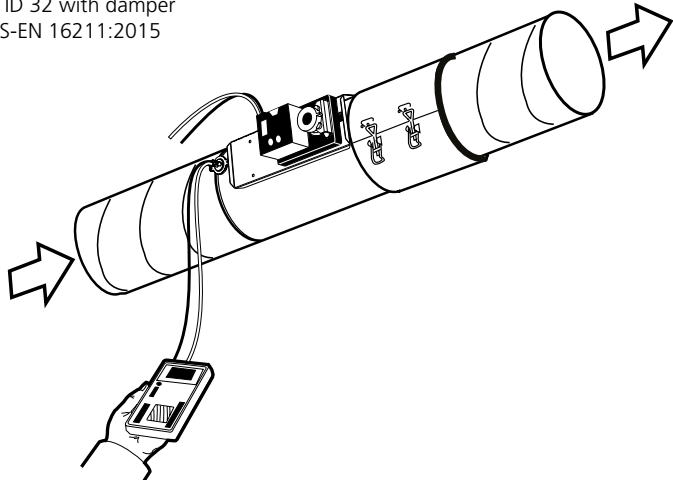

Figure 9. Example VAV/CAV. Number of measuring tubes: 2. Connected to "nipple well". The K-factor is also valid for the combination VAV with sound attenuator CLA L = 500 or 1000 mm.



REACT V - VAV damper REACT M - Unit of measurement - Circular

Size	REACT Va, REACT Ma
100	5,3
125	8,7
160	15,5
200	24,8
250	40,0
315	63,4
400	102,0
500	164,0
630	264,0

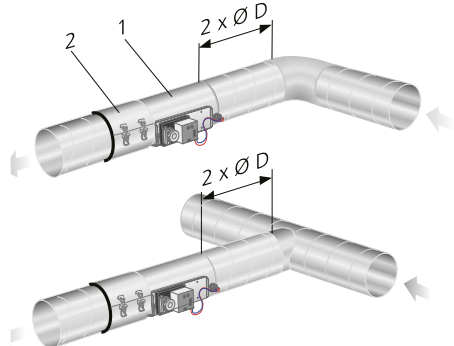
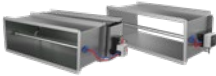

Figure 10. Straight section requirements, circular ducts.

VAV/CAV and commissioning damper



REACT V - VAV damper, REACT M - Unit of measurement - Rectangular

Size	REACT Va, REACT Ma
200-200	33,5
300-200	50,0
400-200	66,5
500-200	83,5
600-200	100,0
700-200	117,0
800-200	133,0
1000-200	167,0
300-300	76,0
400-300	102,0
500-300	127,0
600-300	152,0
700-300	178,0
800-300	203,0
1000-300	254,0
400-400	136,0
500-400	171,0
600-400	205,0
700-400	239,0
800-400	273,0
1000-400	341,0
1200-400	409,0
1400-400	478,0
1600-400	546,0

Size	REACT Va, REACT Ma
500-500	214,0
600-500	257,0
700-500	300,0
800-500	343,0
1000-500	429,0
1200-500	514,0
1400-500	600,0
1600-500	686,0
600-600	309,0
700-600	361,0
800-600	412,0
1000-600	515,0
1200-600	618,0
1400-600	722,0
1600-600	825,0
700-700	422,0
800-700	482,0
1000-700	603,0
1200-700	723,0
1400-700	844,0

Type of obstruction	E (u ₂ =5%)	E (u ₂ =10%)
One 90°-bend	E = 3 x B	E = 2 x B
One T-piece	E = 3 x B	E = 2 x B

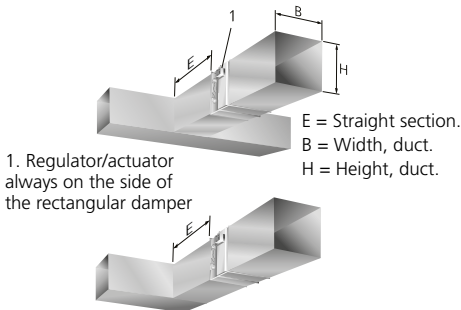

Figure 11. Straight section requirements, rectangular ducts. Dimensions B and H (B = Width, H = Height) can be read off the label on the delivered product.

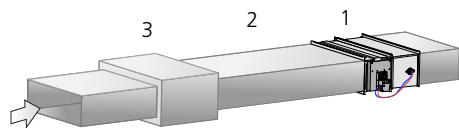

Figure 12. Straight section requirements, rectangular REACT and sound attenuator with baffles. Installation with a length of straight duct applies to both the supply air and the extract air.

- 1 = Rectangular Variable-flow damper REACT.
- 2 = $\geq 3xB$ length of straight duct.
- 3 = Sound attenuator with baffles.



SIRI

SIRIa – K-factors for curen sizes dependent of damper position						
Damper position	80	100	125	160	200	250
1	3,9	6,0	10,2	21,3	35,4	53,3
2	2,1	3,8	6,7	15,0	24,7	39,3
3	1,2	2,6	4,7	11,1	18,3	30,4
4	0,7	1,8	3,3	8,5	14,0	24,2
5	0,3	1,2	2,3	6,6	10,8	19,4
6		0,7	1,5	5,1	8,4	15,7
7				3,9	6,4	12,6
8					4,9	10,1
9						7,8

SIRIa – K-factors for curen sizes dependent of damper position					
Damper position	315	400	500	630	800
1	85,3	119,0	218,0	325,0	540,0
2	65,3	95,3	176,0	272,0	446,0
3	52,1	78,5	148,0	233,0	379,0
4	42,9	65,7	124,0	202,0	325,0
5	35,6	55,6	107,0	177,0	282,0
6	29,8	47,2	93,1	156,0	247,0
7	24,9	40,1	81,2	139,0	216,0
8	20,7	34,0	71,0	123,0	190,0
9	17,0	28,7	62,0	109,0	167,0
10	13,9	23,8	54,0	63,7	147,0
11	11,1	19,5	46,7	85,8	129,0
12		15,6	40,4	75,6	112,0
13		12,3	34,4	66,8	98,7
14			29,4	58,9	85,6

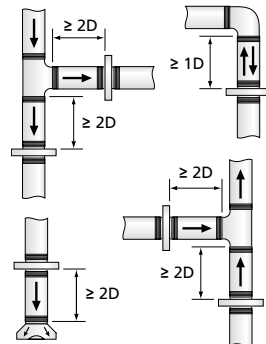

Figure 13. Installation alternatives and straight duct length demands.

VAV/CAV and commissioning damper

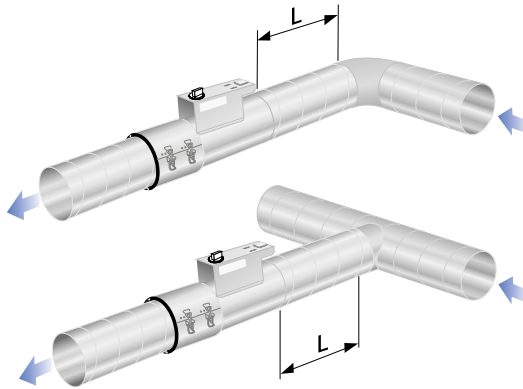

Figure 14. Straight duct length demands, see table below.

Type of obstruction upstream of the CRM	Length of straight duct (L) upstream of the CRM	
	For $m_2=5\%$	For $m_2=10\%$
One 90° bend.	3 x Ød	2 x Ød
Two 90° bends in the same plane.	4 x Ød	2 x Ød
Two 90° bends in alignment at right angles to one another.	4 x Ød	2 x Ød
One 45° damper.	6 x Ød	3 x Ød
One T-piece.	4 x Ød	3 x Ød

u_2 = error of method according to standard SS-EN 16211:2015 and measurement method ID 31 and ID 32.



CRM 1



CRM 5

Size	CRMc 1	CRMc 5
100	9,2	9,2
125	9,6	9,6
160	15,8	15,8
200	23,5	23,5
250	35,6	35,6
315	59,2	59,2
400	95,6	95,6
500	147,0	147,0
630	230,0	230,0

Number of measuring tubes: 2

Notes

