

ALG_C

Installation – Commissioning – Maintenance

20191028

Accessory

Commissioning box:

TRG. Made of galvanised sheet steel. Contains a removable damper, mounting frame with air distribution plate, fixed measurement tapping and sound absorbent insulation covered by a reinforced surface layer, rated to Fire Resistance Class B-s1,d0 conforming to EN ISO 11925-2.

Mounting frame with damper:

FHA. Made of galvanised sheet steel. With a slide damper in the rear. Can be used as a simpler option instead of the TRG. NOTE! No flow measurement function.

Mounting frame:

FHB. Made of galvanised sheet steel. Used if no commissioning box or FHA is installed.

Installation

The opening should be cut according to the nominal width and height dimensions specified. Press the mounting frame (FHA/FHB) into the duct and secure it in position with blind rivets. Then press the grille into the mounting frame to secure it firmly. If a TRG commissioning box is used, pull the telescopic mounting frame out of the box. Push the box from the rear into the opening and secure the box to the building structure with mounting brackets or hangers. Push the telescopic mounting frame into the box from the room side, and secure it to the sides with blind rivets. See Figure 2.

Then press the grille into the mounting frame. If the sum of the width and height of the grille exceeds 700 mm, the grille will have to be secured with screws to the wall using the countersunk screw holes.

Commissioning

Commissioning must be carried out with the grille mounted. Pull the measuring tubes and damper adjustment cords out through the vanes of the grille. Then connect a manometer to the measuring tube(s). The rated coefficient of performance of the air register can be used in a calculation to determine the required commissioning pressure. Conclude commissioning by adjusting the damper to the correct blade position, tie a commissioning knot in the damper cords to indicate the damper position. See Figure 1.

The K-factor (COP) is specified on the product's identification label. K-factors can also be found in the relevant commissioning instructions at www.swegon.com.

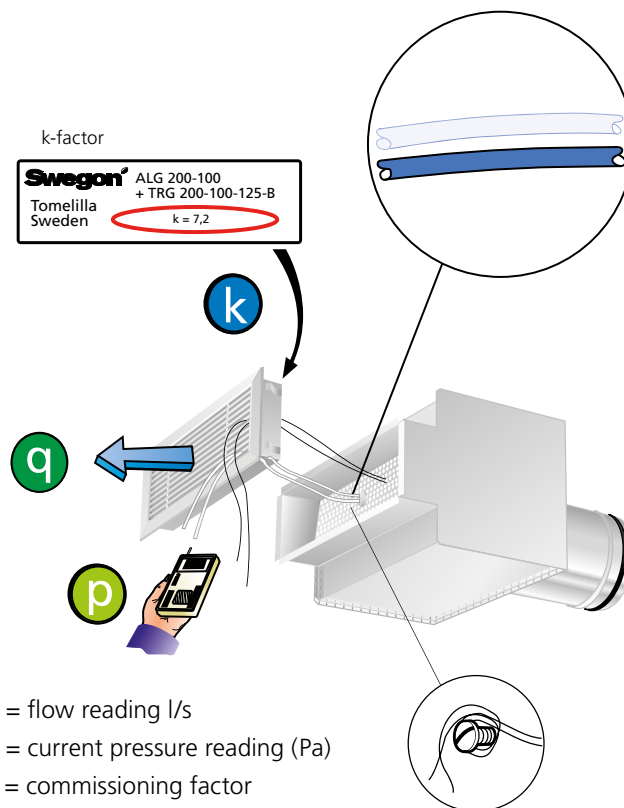

Figure 1. Commissioning.

Free area

To obtain the free area, multiply the inner area of the grille by a factor of $f = 0.52$.

Example:

Grille: ALG 400-200

The inner area of the grille: $(0.4 - 0.02) \times (0.2 - 0.02) = 0.0684 \text{ m}^2$

The free area of the grille: $0.52 \times 0.0684 = 0.036 \text{ m}^2$

Maintenance

The air diffuser can be cleaned, if necessary, using lukewarm water with dishwashing detergent added or by vacuum cleaning using a brush nozzle. If a TRG commissioning box is used and if necessary the TRG inner surfaces should be vacuum cleaned. The duct system can be reached for cleaning by pulling it out of its mounting frame. Remove the flow-measuring plate out of the mounting frame and the damper unit is removed by turning the damper out its bayonet fastener. See Figure 2.

Installation

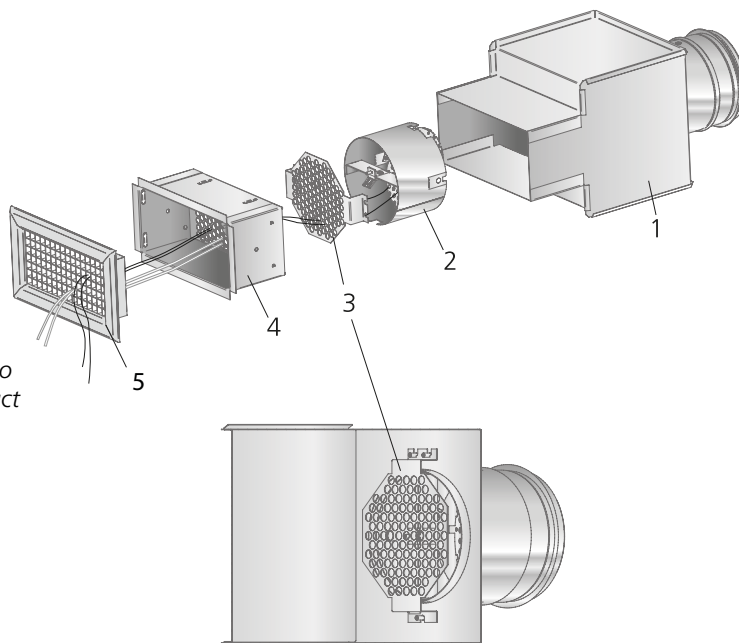

Figure 2. Installation. Commissioning.
To secure the damper action (2) in the duct connection and to secure the octagonal perforated face plate (3) against the duct connection.

1. Commissioning box
2. Damper action
3. Octagonal air distribution plate
4. Mounting frame
5. Grille

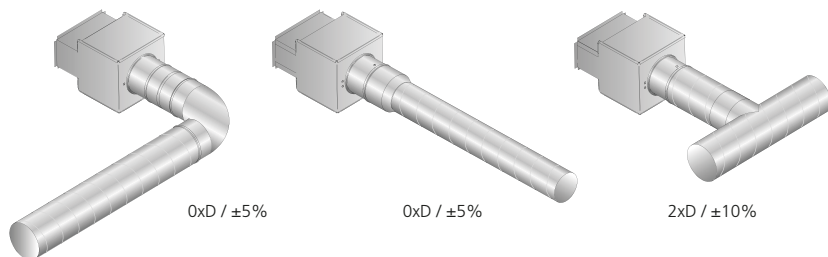

Figure 3. Installation alternatives, applies for all connections (B, K, L)

Dimensions and weights

Dimension table, TRG

Size	A	B	C	ØD
200-100	203	100	80	124
300-100	303	100	100	159
400-100	403	100	100	159
500-100	503	100	120	199
300-150	303	150	120	199
400-150	403	150	145	249
500-150	503	150	145	249
400-200	403	200	145	249
500-200	503	200	180	314
600-200	603	200	180	314

Size	F	I	G	Weight, kg
200-100	175	98	195	2.7
300-100	210	115	230	3.9
400-100	210	115	230	4.7
500-100	245	135	270	7.5
300-150	270	135	270	5.3
400-150	305	160	320	6.8
500-150	305	160	320	7.8
400-200	330	160	320	8.5
500-200	360	194	387	9.8
600-200	360	194	387	11.0

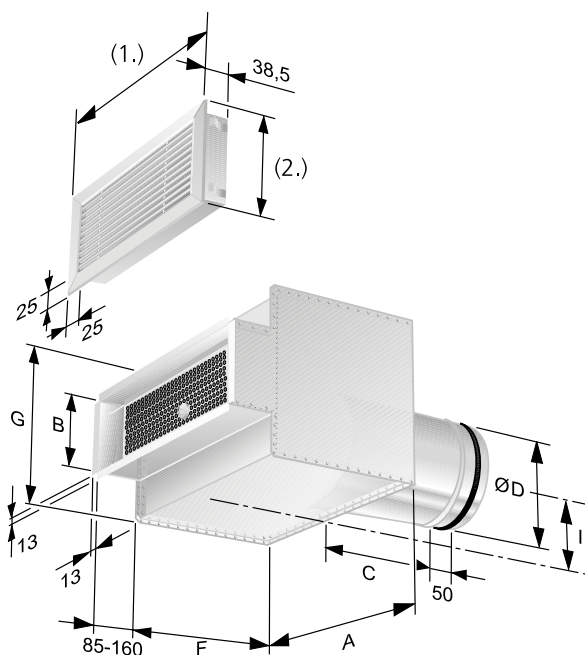

Figure 4. ALG.
(1.) Nominal width + 30 mm
(2.) Nominal height + 30 mm

To obtain the exact dimensions of the grill, add the values given in the ALG figure to its nominal dimensions.

Hole making size, fixing frame FHB = nominal dimensions. (Grille size designation.)

Size of the opening, TRG = nominal dimensions + 5mm (Size designation of the grille + 5mm).

Table of dimensions ALG

Size	Weight, kg
200-100	0,4
300-100	0,5
400-100	0,6
500-100	0,7
300-150	0,7
400-150	0,8
500-150	1,0
400-200	1,1
500-200	1,3
600-200	1,5

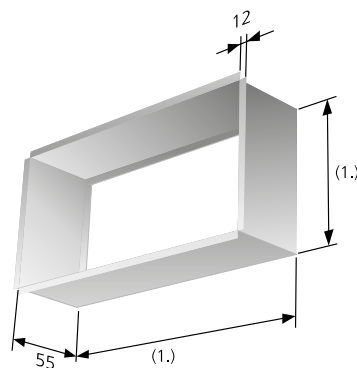

Figure 5. FHB mounting frame
(1.) Nom. -3 mm.

K-factor (Rated COP)

TRGd Size	ALGc, supply air		
	Conn. B	Conn. K	Conn. L
200-100-125	7.2	7.1	7.4
300-100-160	11.9	12.2	12.3
400-100-160	15.9	16.2	15.5
500-100-200	21.4	21.4	22.2
300-150-200	19.6	19.4	20.2
400-150-250	26.9	26.3	27.3
500-150-250	35.0	34.5	32.4
400-200-250	36.8	38.5	42.0
500-200-315	52.4	50.8	48.5
600-200-315	61.9	60.7	57.6

Number of measuring tubes: 2.

Connection option: B= Rear, K = Short side, L = Long side

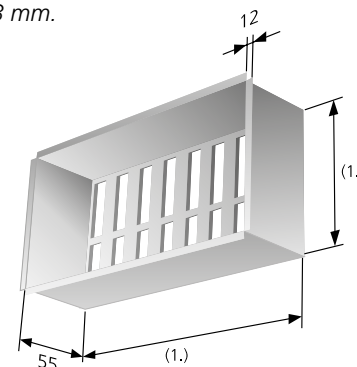

Figure 6. FHA mounting frame with slide damper.
(1.) Nom. -3 mm.

TRGd Size	ALGc, extract air		
	Conn. B	Conn. K	Conn. L
200-100-125	7.6	7.7	7.2
300-100-160	13.4	13.0	12.3
400-100-160	19.3	18.2	17.4
500-100-200	23.2	23,0	21,2
300-150-200	20.9	21.4	19.2
400-150-250	28.9	28.2	26.4
500-150-250	36.3	35.7	33.3
400-200-250	45.6	44.3	41.0
500-200-315	56.3	56.1	51.5
600-200-315	70.7	69.6	61.0

Number of measuring tubes: 2.

Connection option: B= Rear, K = Short side, L = Long side

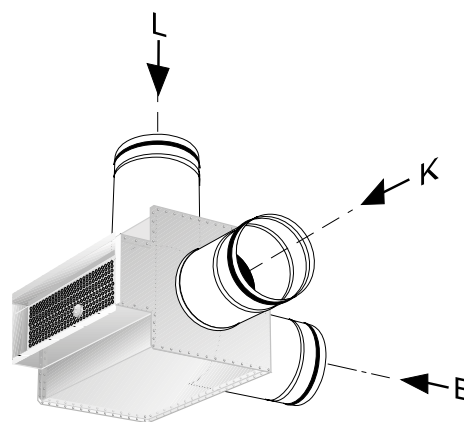

Figure 7. TRG.